

11. Knock Sensor

A: REMOVAL

- 1) Disconnect the ground cable from battery.

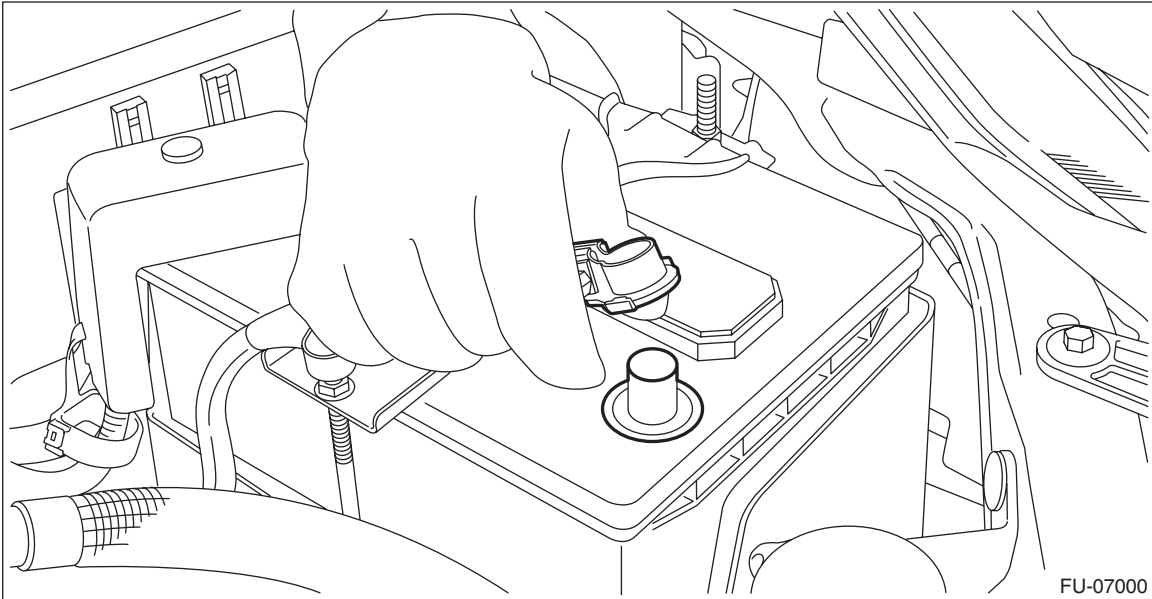

- 2) Remove the clip (A) from the air intake boot.
- 3) Loosen the clamp (B) connecting the air intake boot and air cleaner case (rear).
- 4) Loosen the clamp (C) which connects the air intake boot and throttle body.

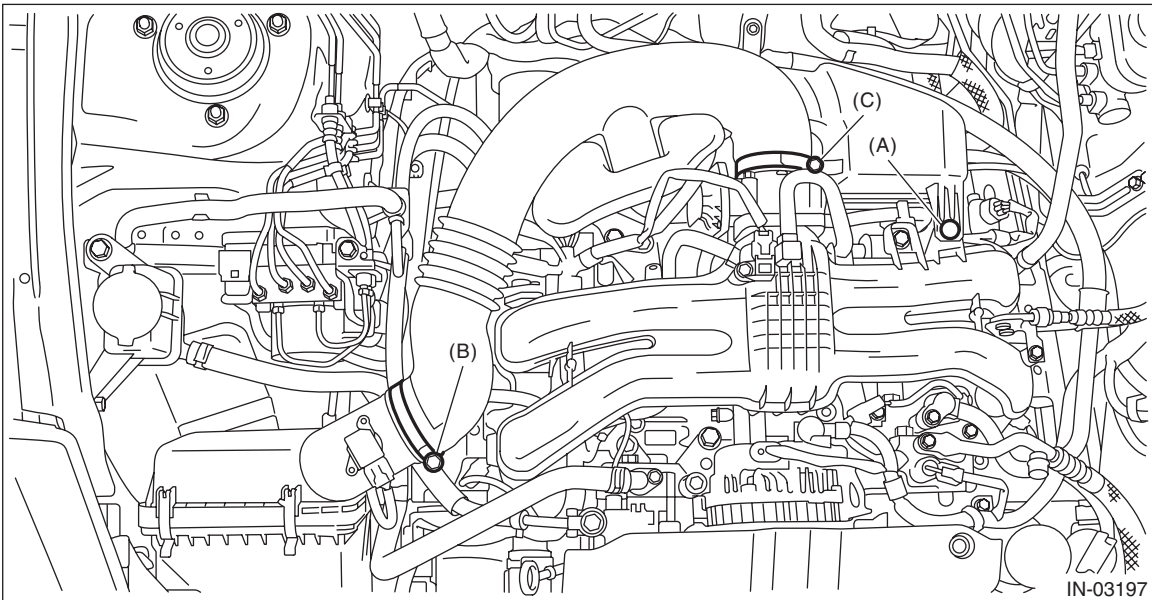

Knock Sensor

FUEL INJECTION (FUEL SYSTEMS)

5) Remove the air intake boot from the throttle body, and move it to the left side wheel apron.

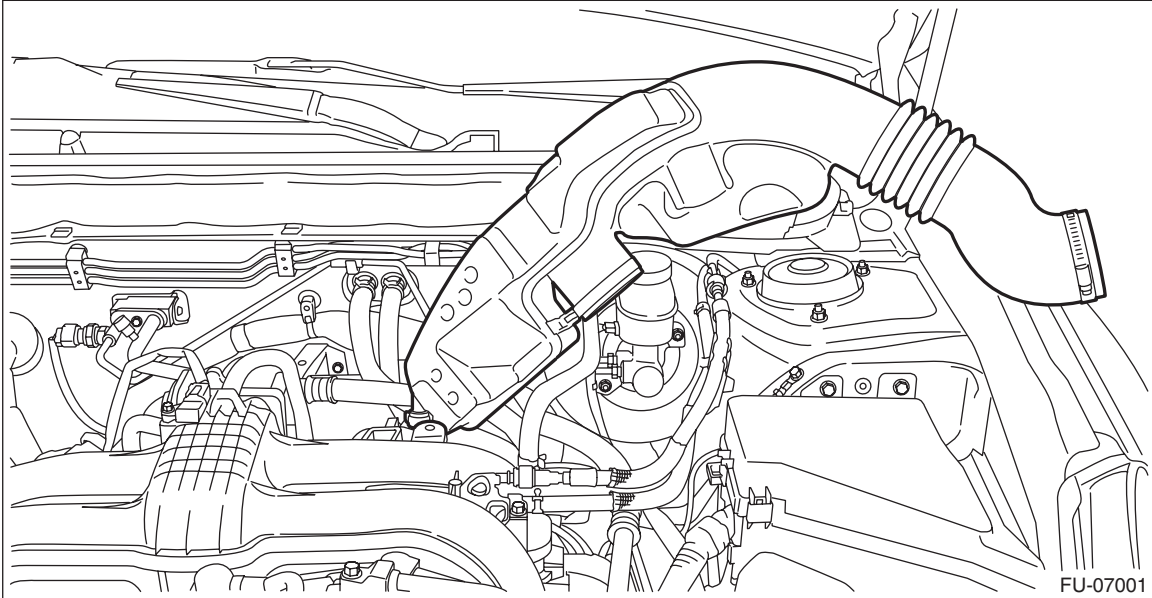

6) Disconnect the connector (A) from the knock sensor, and remove the knock sensor from the cylinder block.

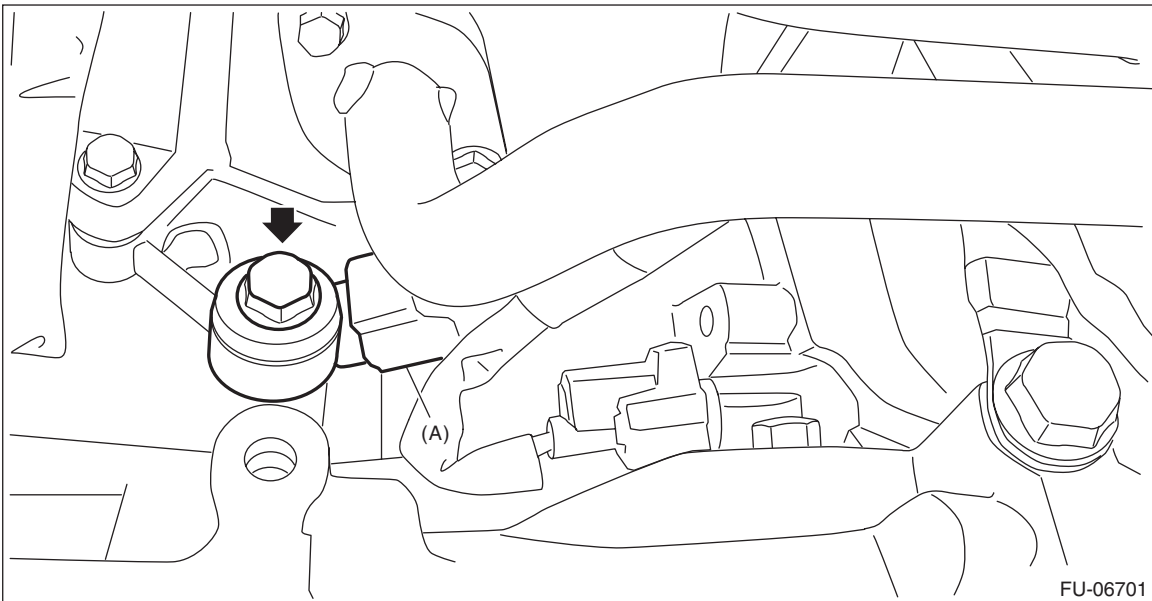

B: INSTALLATION

1) Install the knock sensor to the cylinder block.

NOTE:

The knock sensor should be installed so that the center of the connector is positioned at a $76.5 - 91.5^\circ$ angle relative to the front of engine.

Tightening torque:

24 N·m (2.4 kgf·m, 17.7 ft·lb)

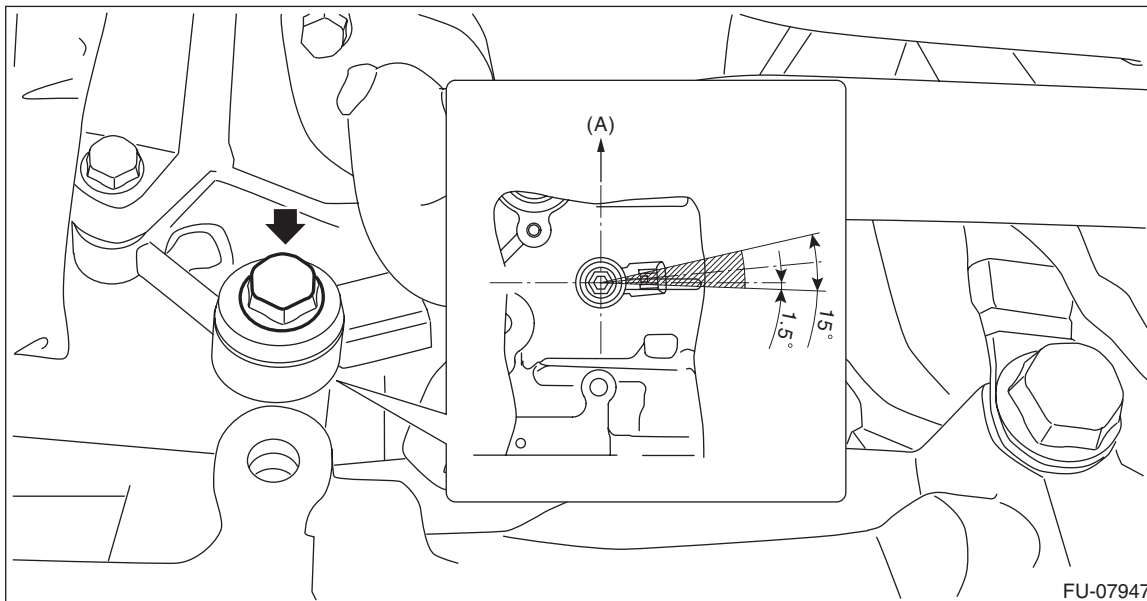

(A) Front of engine

2) Connect the connector to the knock sensor.

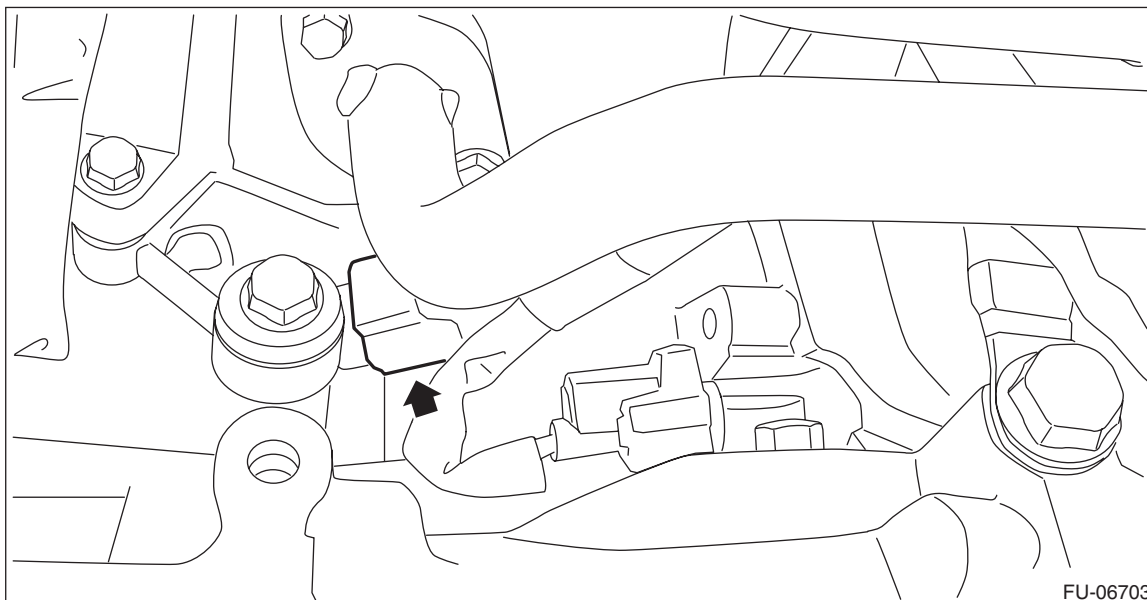

3) Install the air intake boot. <Ref. to IN(H4DO)-13, INSTALLATION, Air Intake Boot.>

Knock Sensor

FUEL INJECTION (FUEL SYSTEMS)

4) Connect the battery ground terminal.

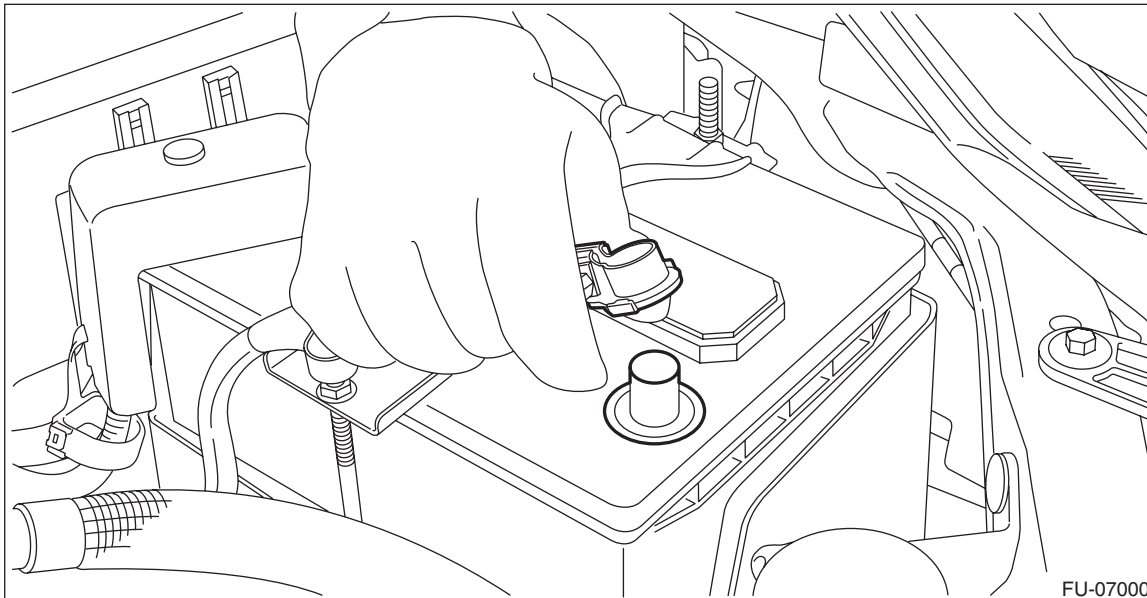

FU-07000

C: INSPECTION

- 1) Check that the knock sensor has no deformation, cracks or other damages.
- 2) Measure the resistance between knock sensor terminals.

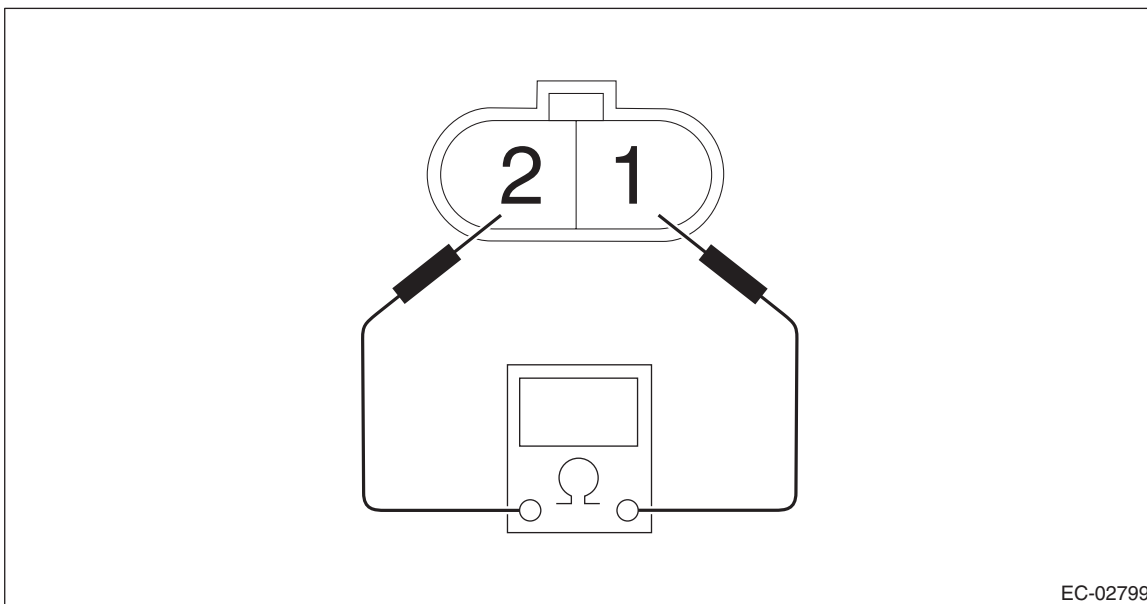

EC-02799

Terminal No.	Standard
1 and 2	560±28 kΩ