

14. Manifold Absolute Pressure Sensor

A: REMOVAL

1) Disconnect the ground cable from battery.

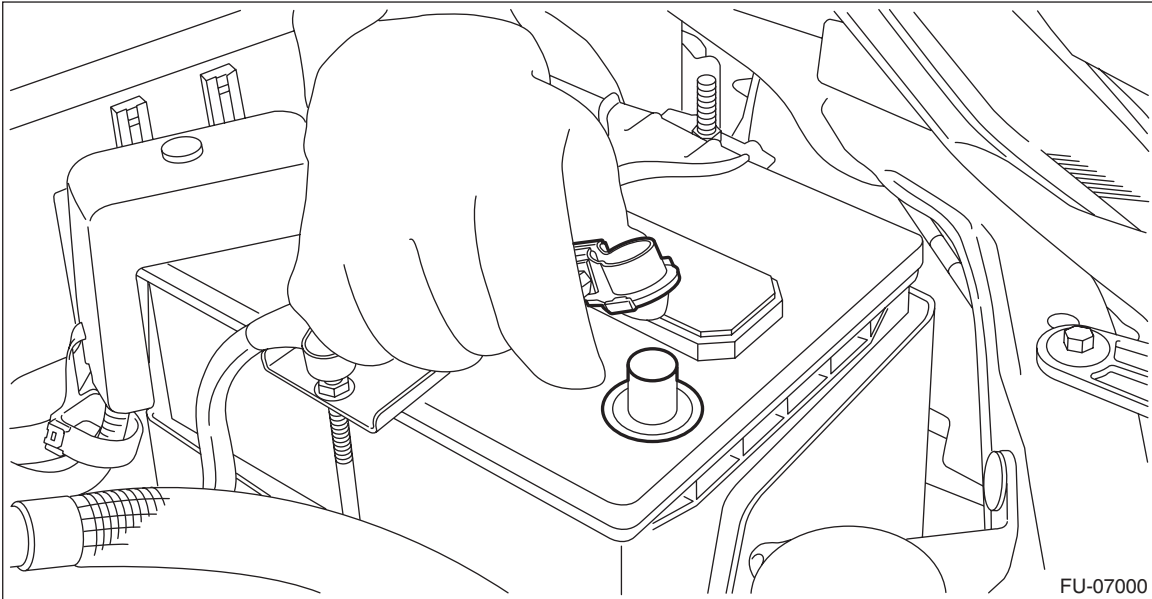

2) Disconnect the connector (A) from the manifold absolute pressure sensor, and remove the manifold absolute pressure sensor from intake manifold.

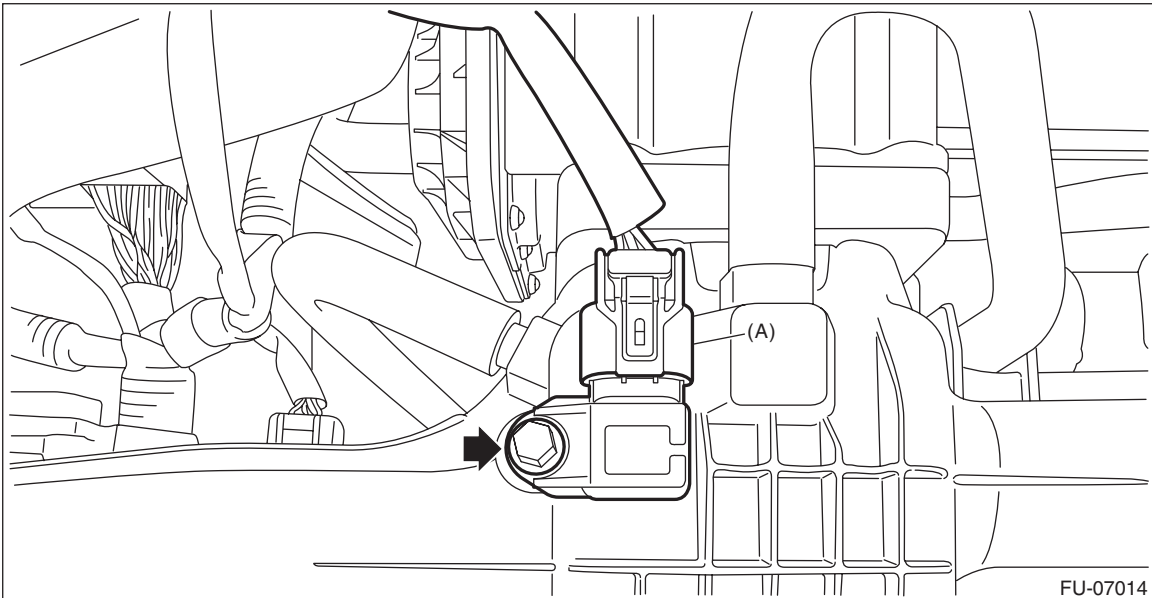

B: INSTALLATION

Install in the reverse order of removal.

NOTE:

Use new O-rings.

Tightening torque:

3.4 N·m (0.3 kgf-m, 2.5 ft-lb)

Manifold Absolute Pressure Sensor

FUEL INJECTION (FUEL SYSTEMS)

C: INSPECTION

- 1) Check that the manifold absolute pressure sensor has no deformation, cracks or other damages.
- 2) Connect dry-cell battery positive terminal to terminal No. 3 and dry-cell battery ground terminal to terminal No. 1, circuit tester positive terminal to terminal No. 2 and the circuit tester negative terminal to terminal No. 1.

NOTE:

- Use new dry-cell batteries.
- Using circuit tester, check the voltage of a single dry-cell battery is 1.6 V or more. And also check the voltage of three batteries in series is between 4.8 V and 5.2 V.

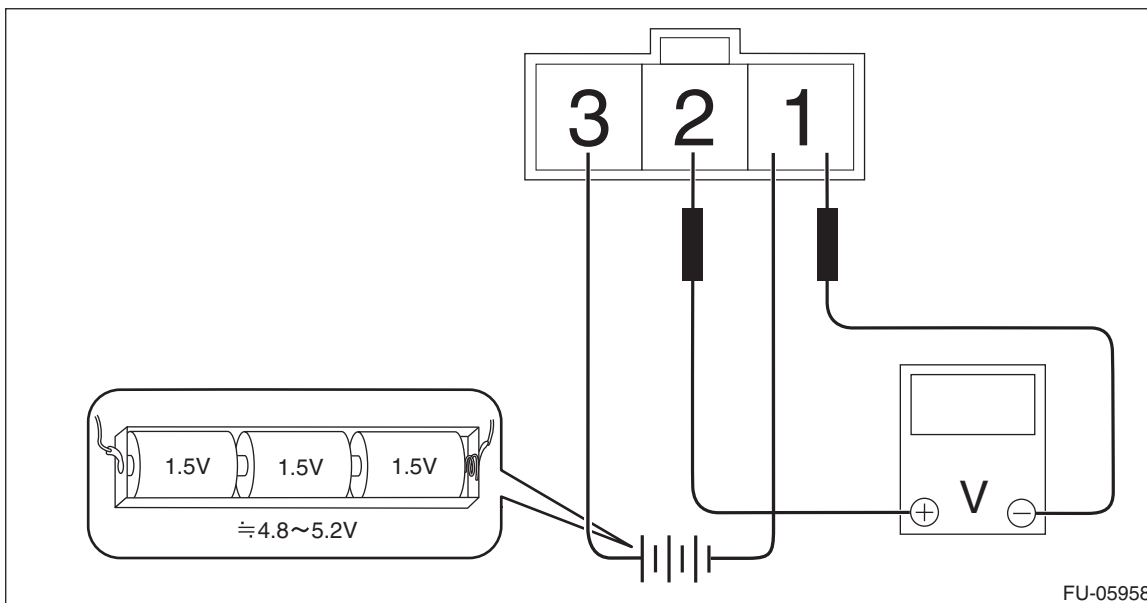

- 3) Check the voltage at a normal atmospheric pressure.

NOTE:

The atmospheric pressure at higher altitude is lower than normal. Therefore, the voltage is lower than the standard value.

Terminal No.	Standard
2 (+) and 1 (-)	Approx. 4.2 V (when 25°C (77°F))

- 4) Connect the Mighty Vac to the pressure port (A) of manifold absolute pressure sensor.

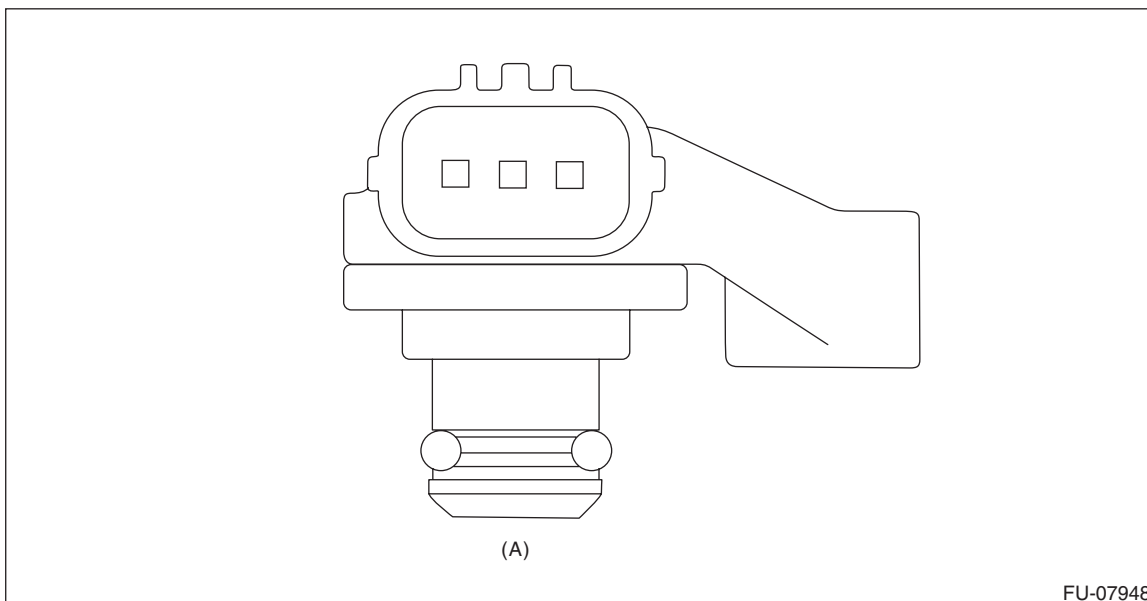

Manifold Absolute Pressure Sensor

FUEL INJECTION (FUEL SYSTEMS)

5) Check the voltage when generating vacuum using Mighty Vac.

CAUTION:

Do not apply vacuum of less than -88 kPa (-0.9 kgf/cm², -12.8 psi). Doing so may damage the manifold absolute pressure sensor.

NOTE:

When vacuum occurs at the pressure port of manifold absolute pressure sensor, the voltage will drop from the value as in step 3).

Pressure	Terminal No.	Standard
-88 kPa (-0.9 kgf/cm ² , -12.8 psi)	2 (+) and 1 (-)	Approx. 1 V (when 25°C (77°F))