

Fuel Tank

FUEL INJECTION (FUEL SYSTEMS)

26. Fuel Tank

A: REMOVAL

WARNING:

Place "NO OPEN FLAMES" signs near the working area.

CAUTION:

- Be careful not to spill fuel.

- Catch the fuel from the tubes using a container or cloth.

1) Release the fuel pressure. <Ref. to FU(H4DO)-109, RELEASING OF FUEL PRESSURE, PROCEDURE, Fuel.>

2) Drain fuel. <Ref. to FU(H4DO)-109, DRAINING FUEL (WITH SUBARU SELECT MONITOR), PROCEDURE, Fuel.>

3) Disconnect the ground cable from battery.

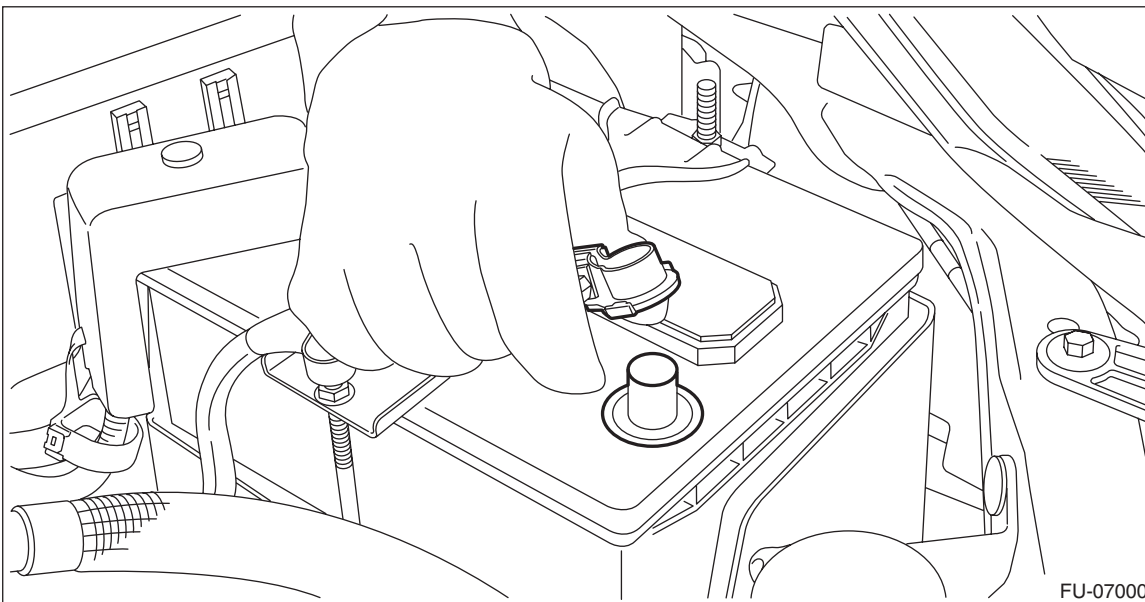

4) Remove the rear seat cushion. <Ref. to SE-34, REMOVAL, Rear Seat.>

5) Remove the clips (A) and seat cushion hooks (B), and turn over the floor mat (C).

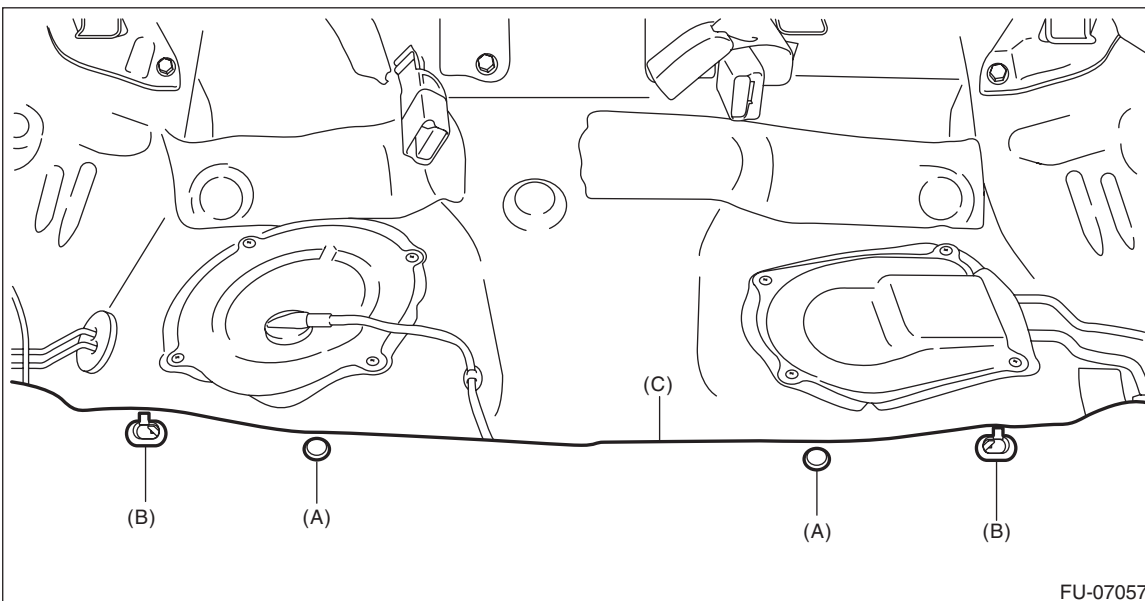

Fuel Tank

- 6) Remove the service hole cover of fuel pump.
- (1) Disconnect the fuel cord connector (A), and remove the clip (B).
 - (2) Remove the screw (C).
 - (3) Push the grommet (D) down and remove the service hole cover.

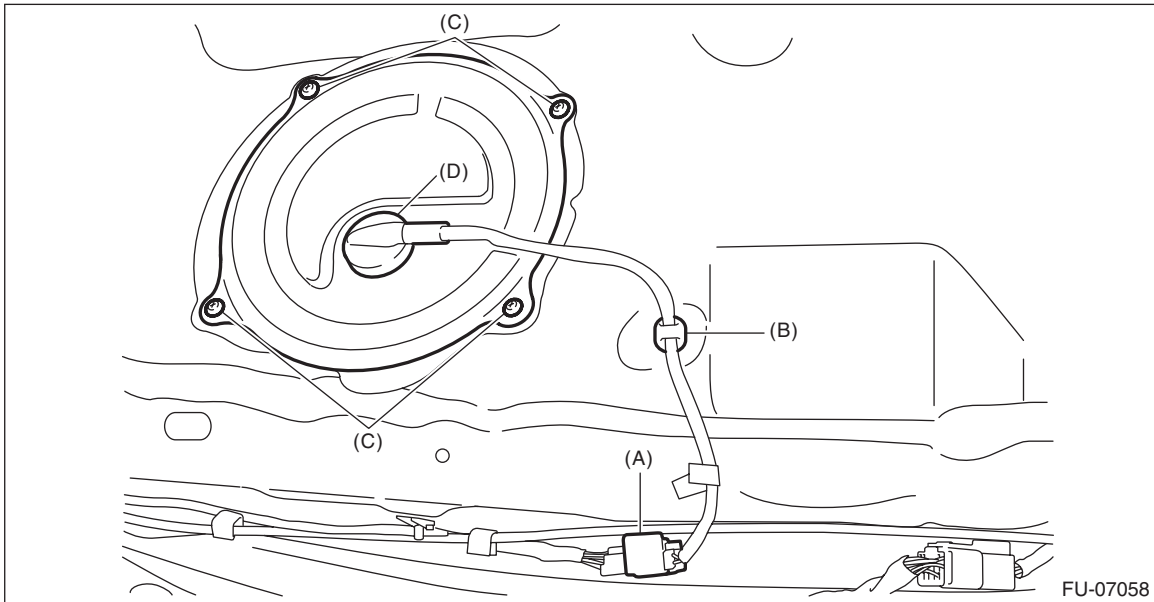

- 7) Remove the service hole cover of fuel sub level sensor.

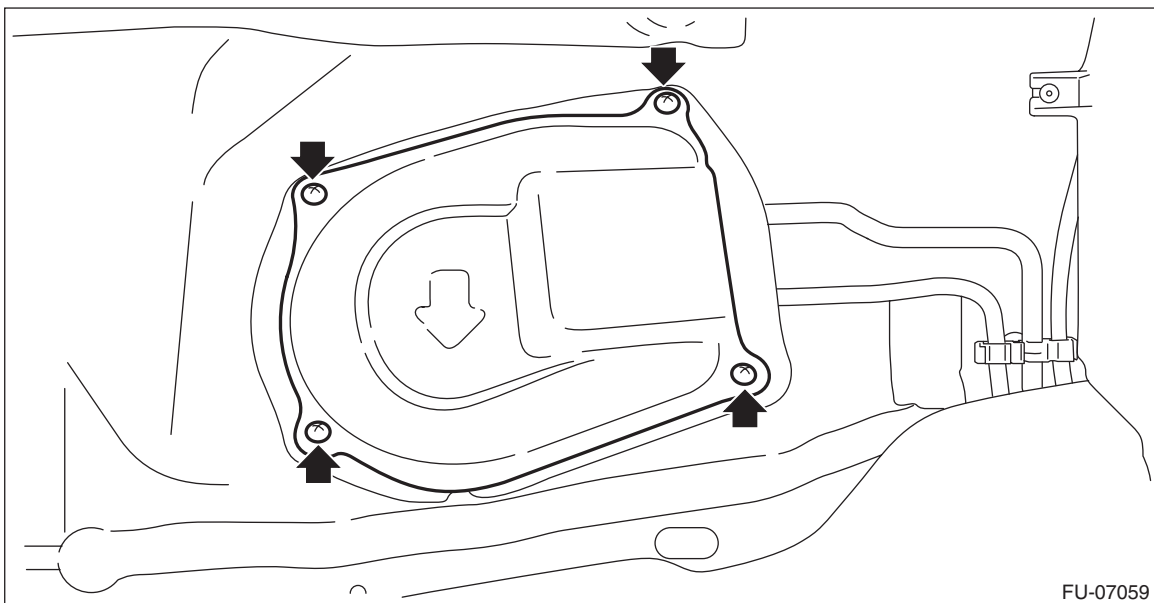

Fuel Tank

FUEL INJECTION (FUEL SYSTEMS)

8) Disconnect the quick connector on the fuel delivery tube. <Ref. to FU(H4DO)-158, REMOVAL, Fuel Delivery and Evaporation Lines.>

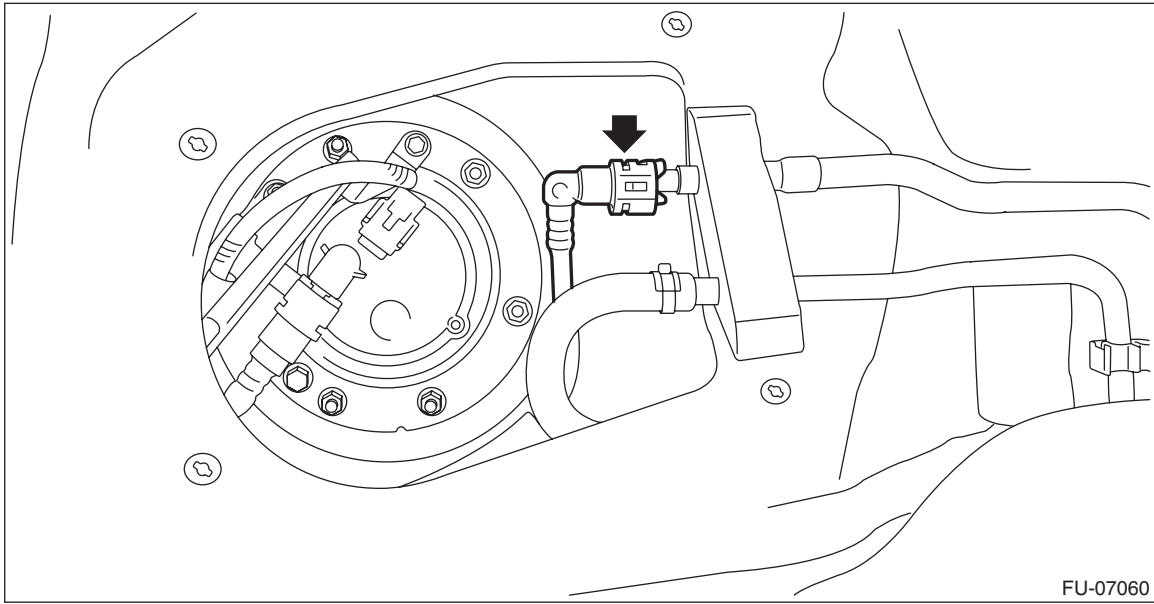

9) Remove the rear wheels.

10) Lift up the vehicle.

11) Remove the rear ABS wheel speed sensor from the rear housing.

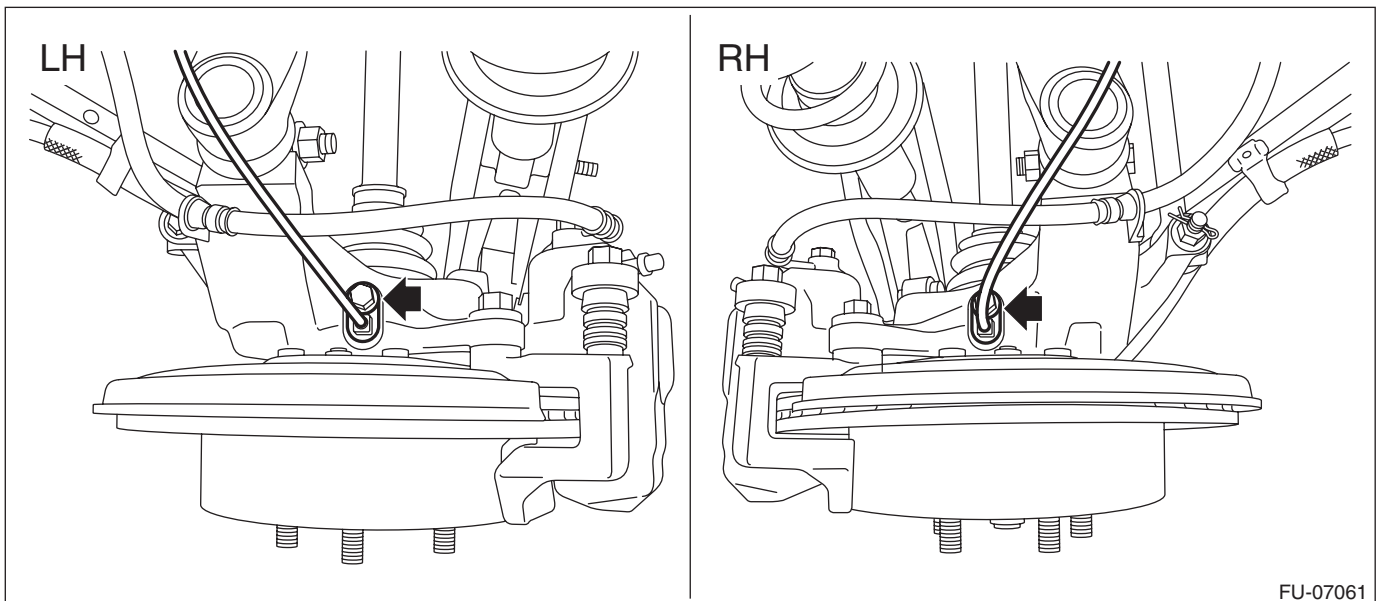

12) Remove the rear ABS wheel speed sensor harness bracket from the upper arm.

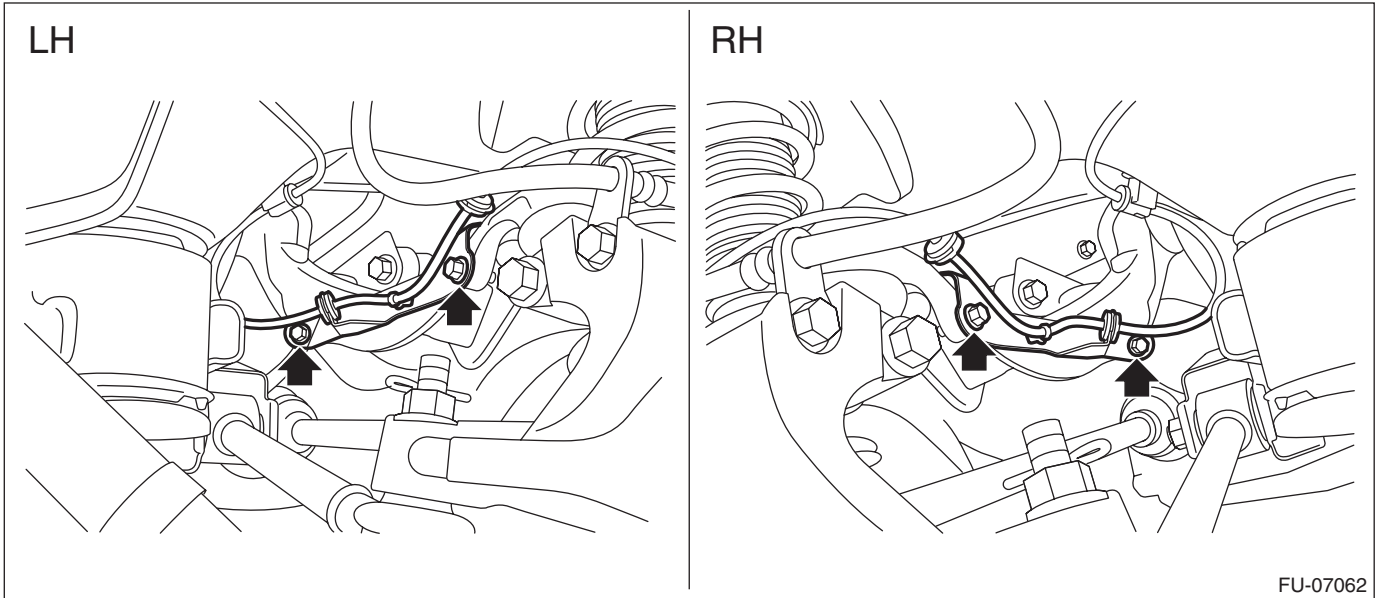

13) Remove the rear brake hose bracket from rear housing.

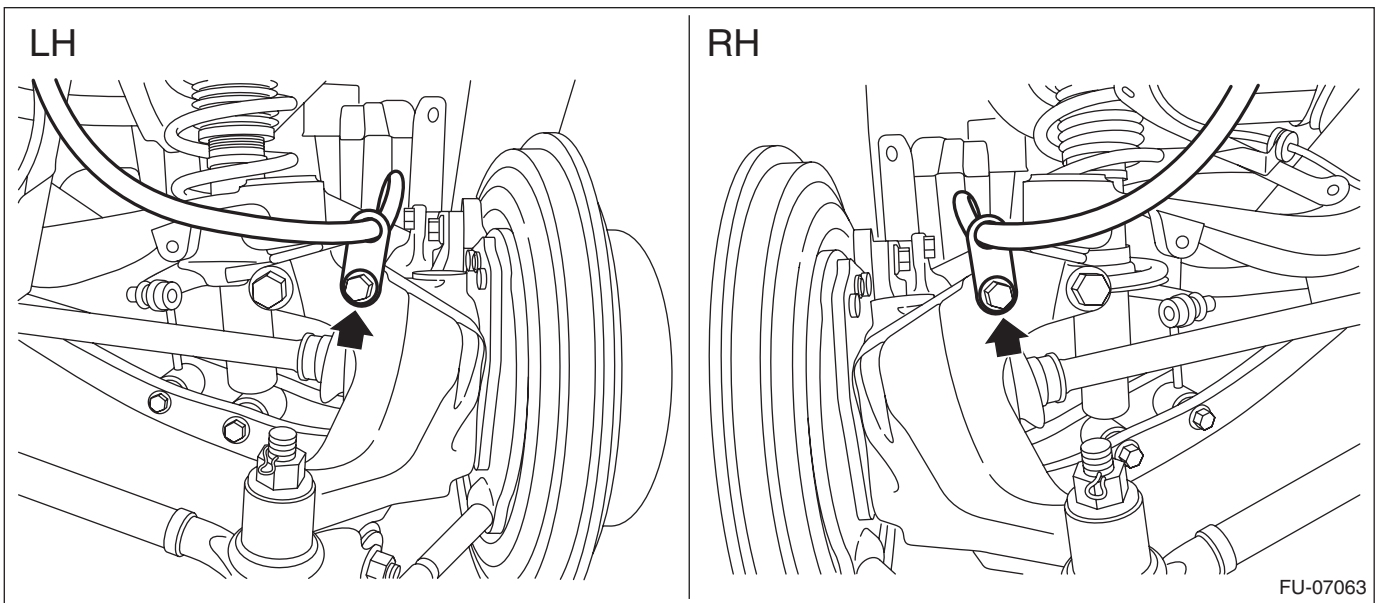

Fuel Tank

FUEL INJECTION (FUEL SYSTEMS)

14) Remove the rear disc brake assembly and tie it to the body side of the vehicle.

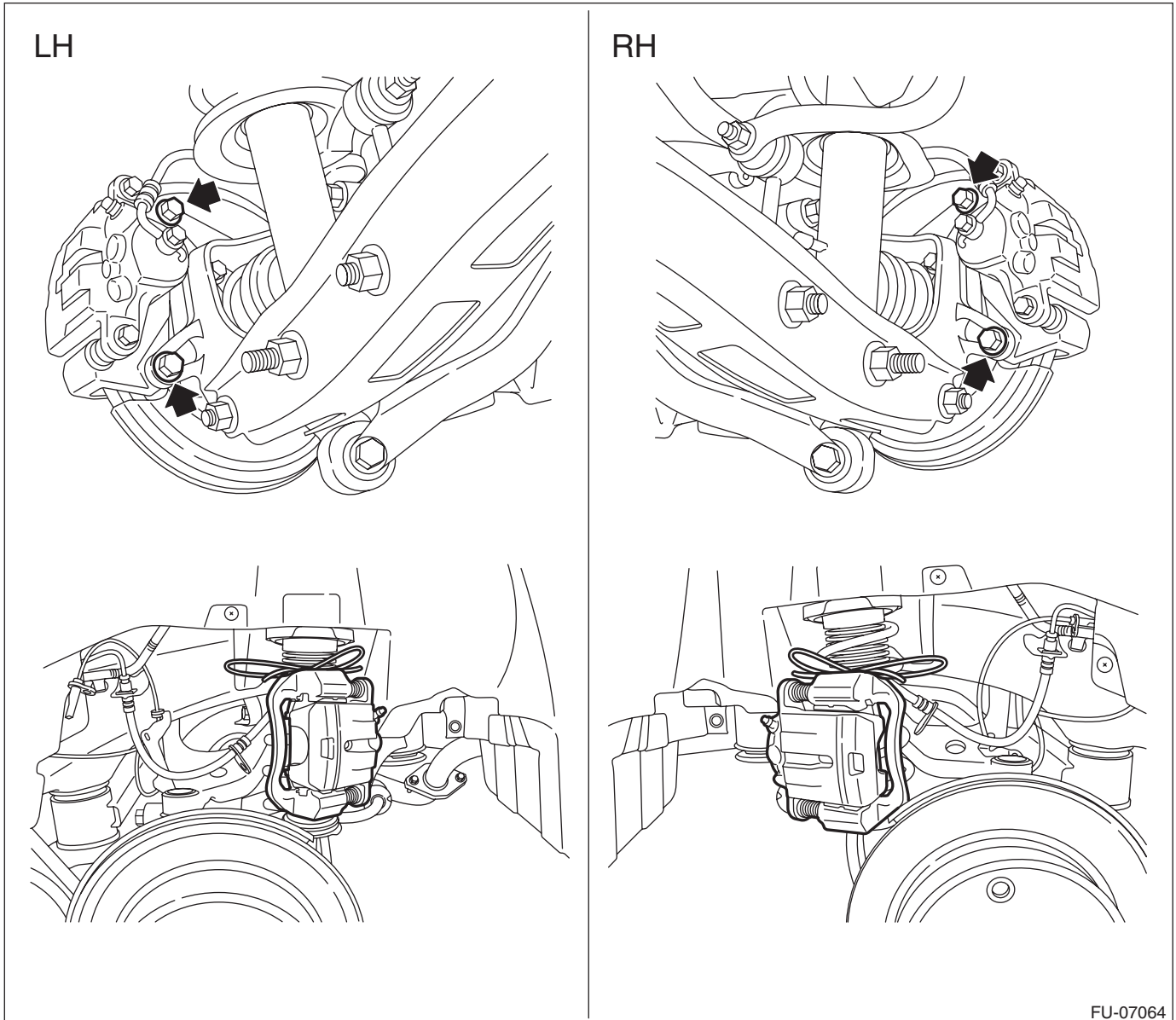

15) Remove the parking brake cable from parking brake assembly. <Ref. to PB-11, REMOVAL, Parking Brake Assembly (Rear Disc Brake).>

16) Remove the rear exhaust pipe and muffler. <Ref. to EX(H4DO)-13, REMOVAL, Rear Exhaust Pipe.>
<Ref. to EX(H4DO)-16, REMOVAL, Muffler.>

17) Remove the propeller shaft. <Ref. to DS-10, REMOVAL, Propeller Shaft.>

Fuel Tank

- 18) Remove bolts (A) and nuts (B) which secure the fuel tank protector, then remove the fuel tank protector.

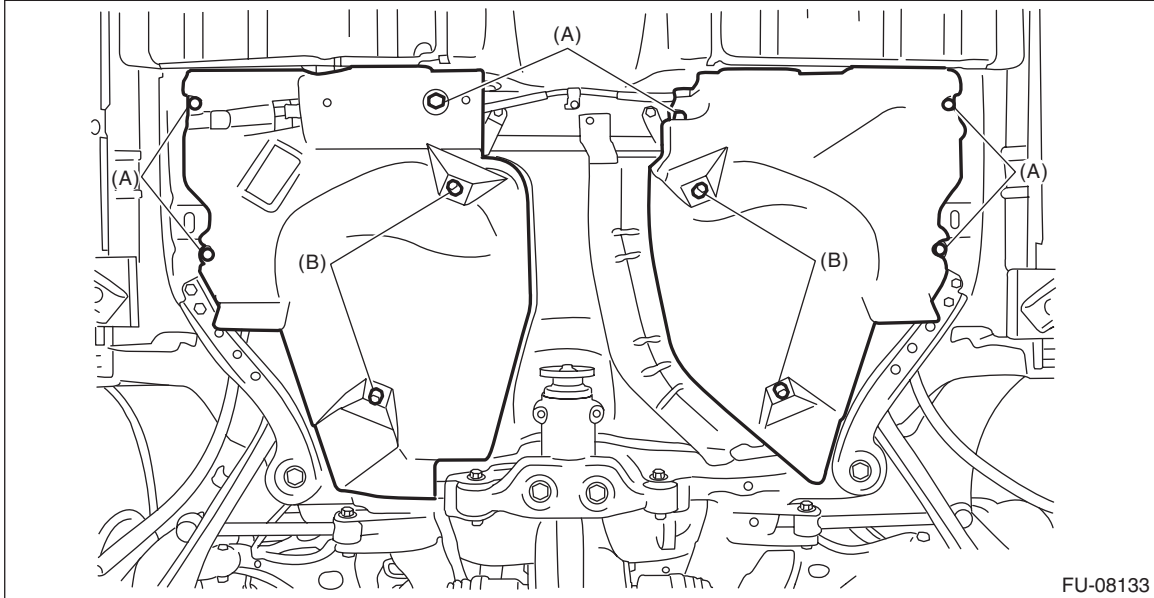

- 19) Remove the bolts and nuts securing the heat shield cover and remove the heat shield cover.

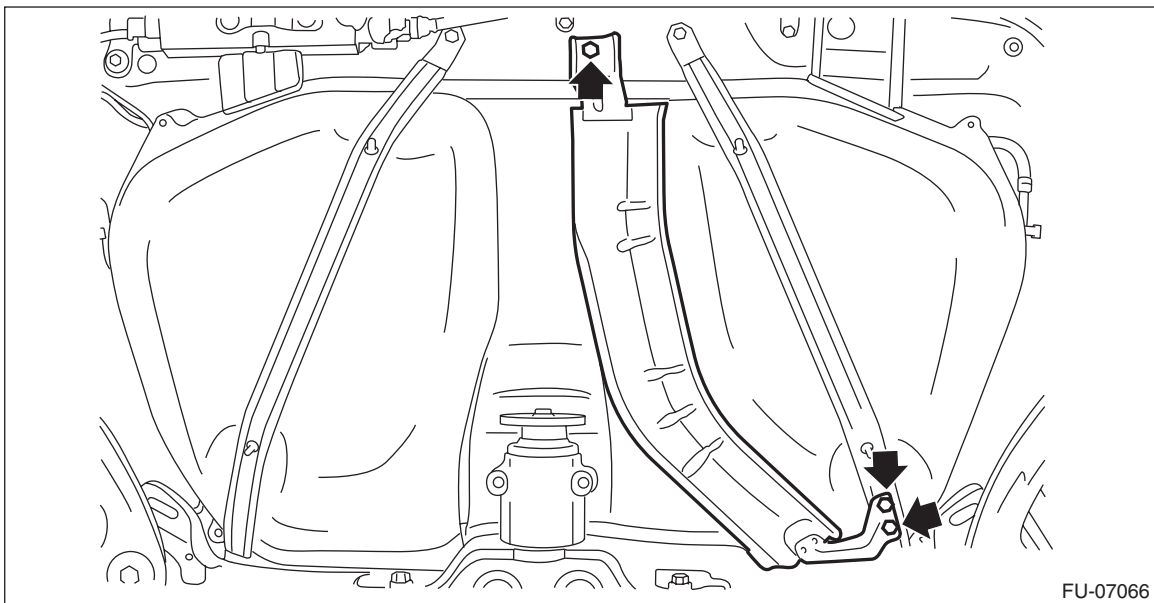

Fuel Tank

FUEL INJECTION (FUEL SYSTEMS)

20) Remove the rear suspension assembly.

WARNING:

A helper is required to perform this work.

- (1) Support the rear differential with the transmission jack.
- (2) Remove the bolt and nut which secure rear shock absorber to rear suspension arm.

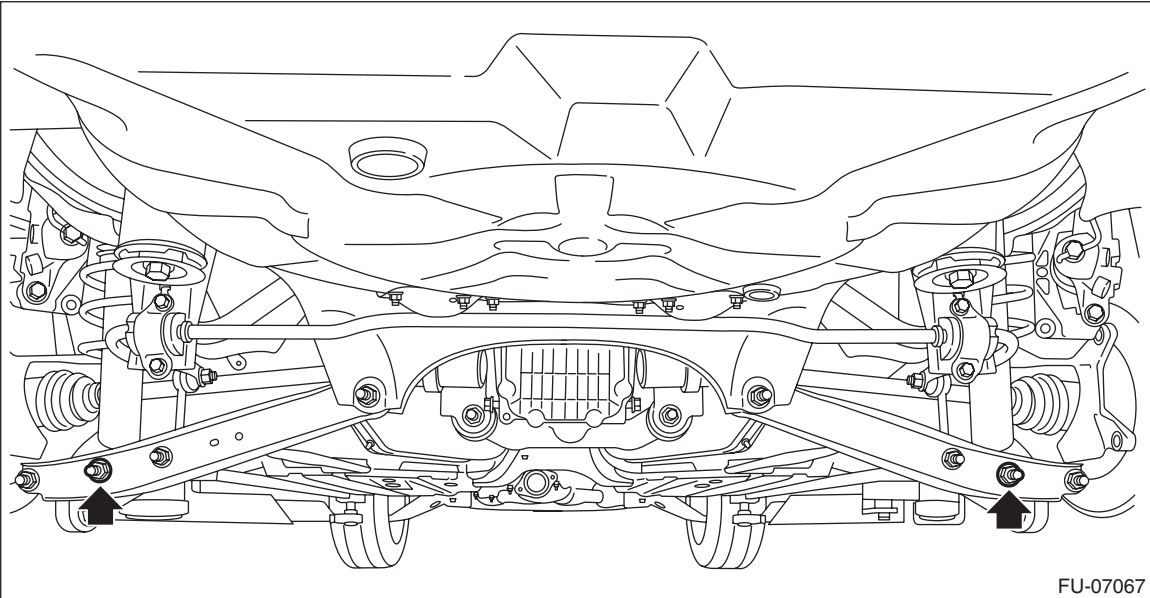

(3) Remove the bolts which secure the rear suspension assembly to the body.

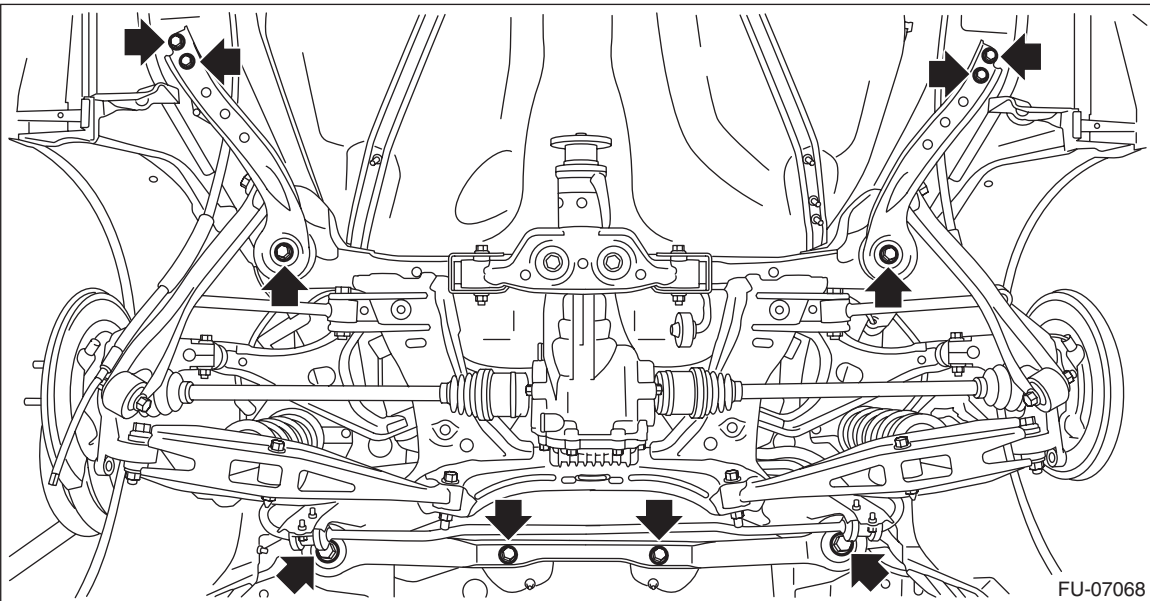

(4) Remove the rear suspension assembly.

Fuel Tank

21) Disconnect the air vent hose from the fuel tank.

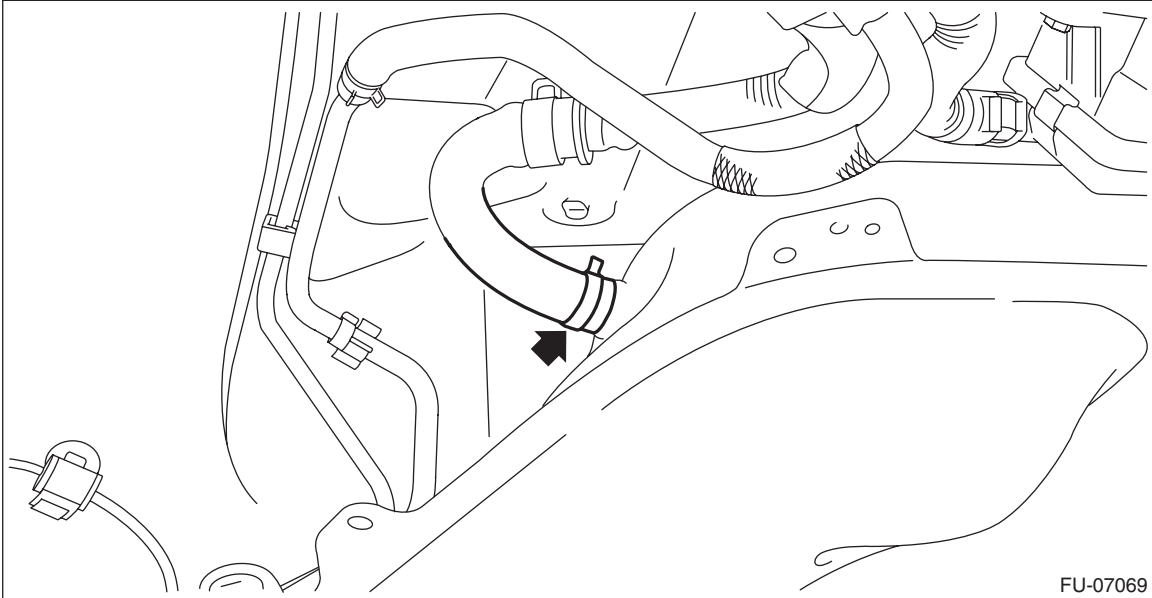

Fuel Tank

FUEL INJECTION (FUEL SYSTEMS)

22) Disconnect the quick connector of the circulate tube from evaporation pipe.

NOTE:

Disconnect the quick connector as shown in the figure.

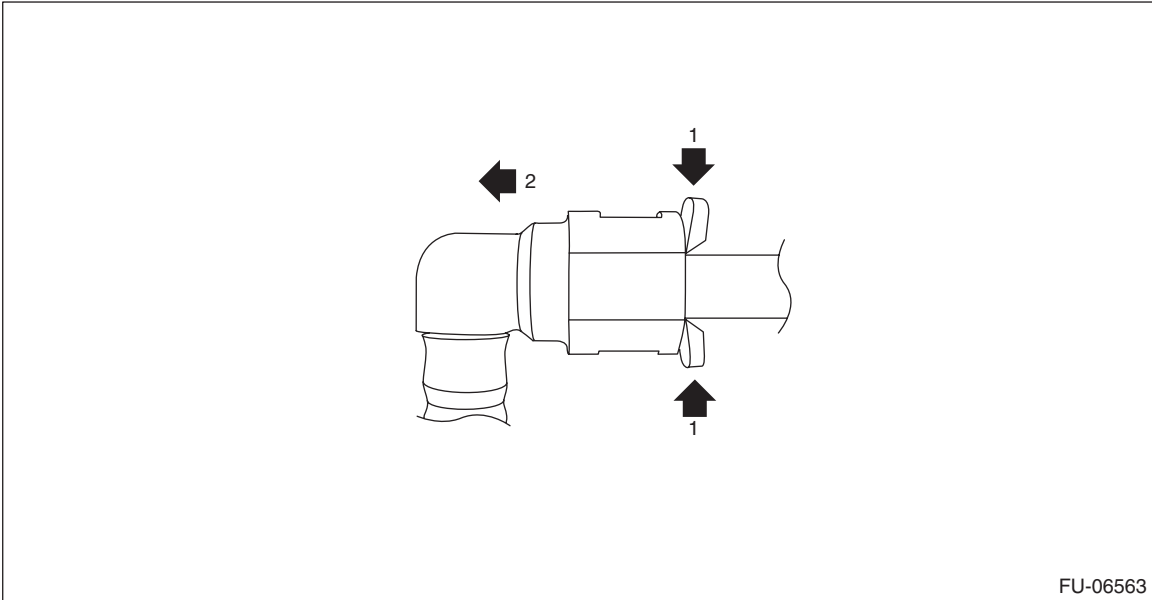

FU-06563

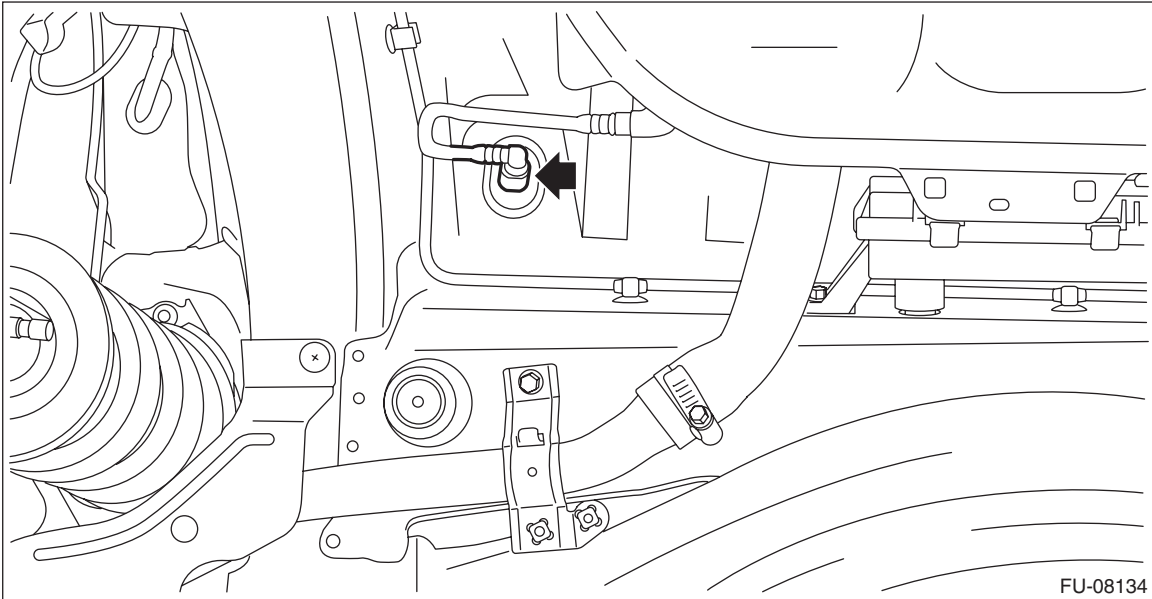

FU-08134

Fuel Tank

23) Disconnect the fuel filler hose from the fuel filler pipe assembly.

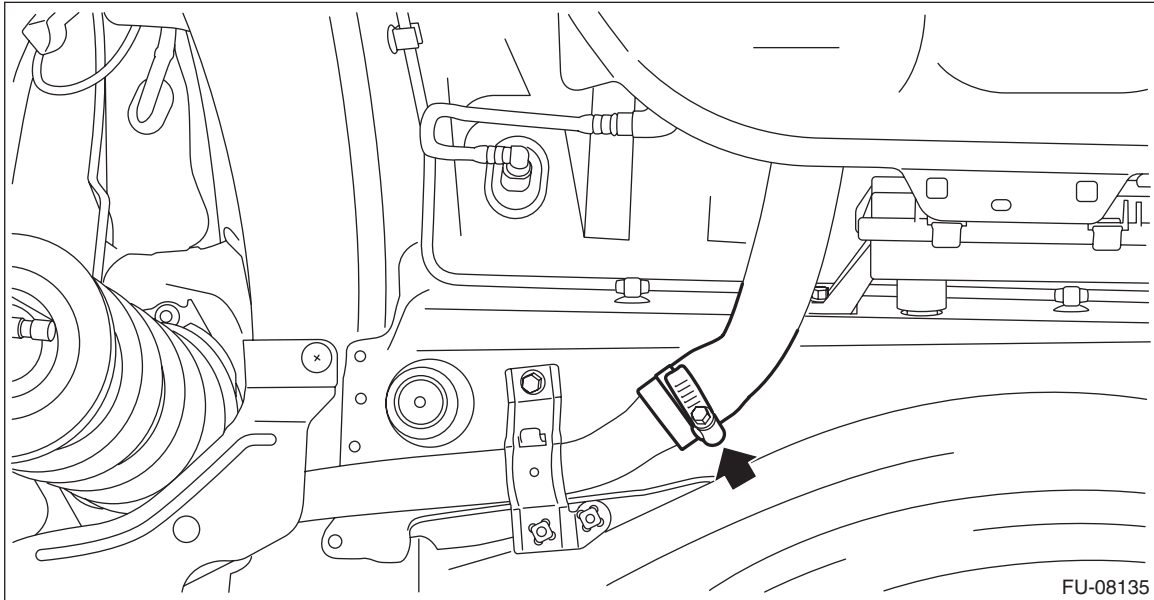

24) Support the fuel tank with a transmission jack, remove the fuel tank band, and remove the fuel tank from the vehicle.

WARNING:

- A helper is required to perform this work.
- Fuel may remain in the fuel tank. This will cause the left and right sides to be unbalanced. Be careful not to drop the fuel tank.

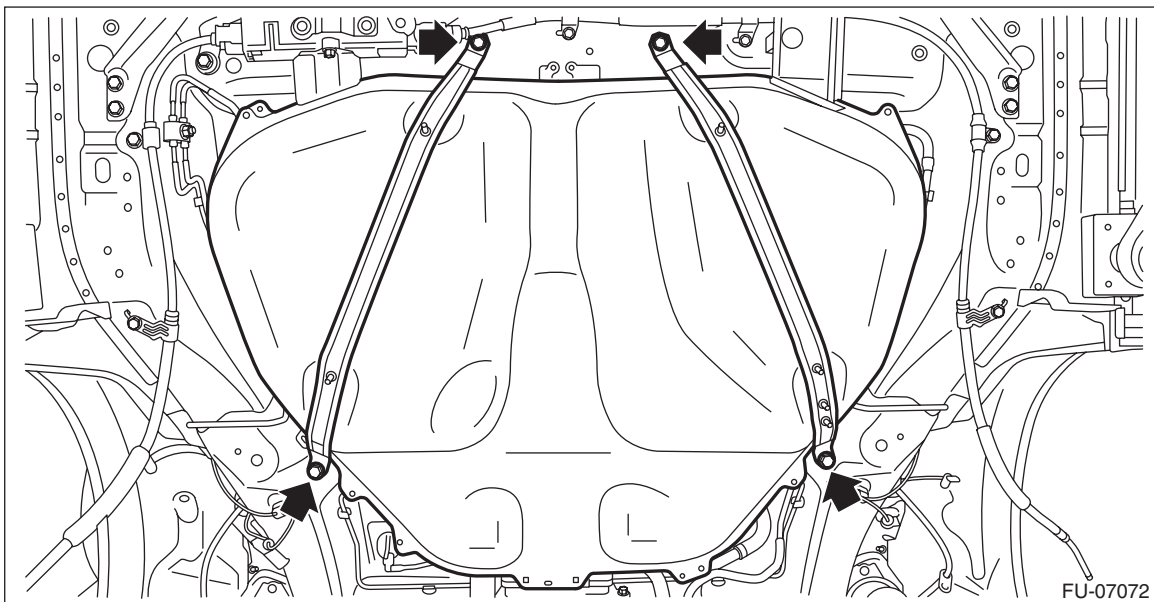

Fuel Tank

FUEL INJECTION (FUEL SYSTEMS)

B: INSTALLATION

1) Support the fuel tank with a transmission jack, set the fuel tank and the fuel tank band in place, and temporarily tighten the bolts of the fuel tank band.

WARNING:

A helper is required to perform this work.

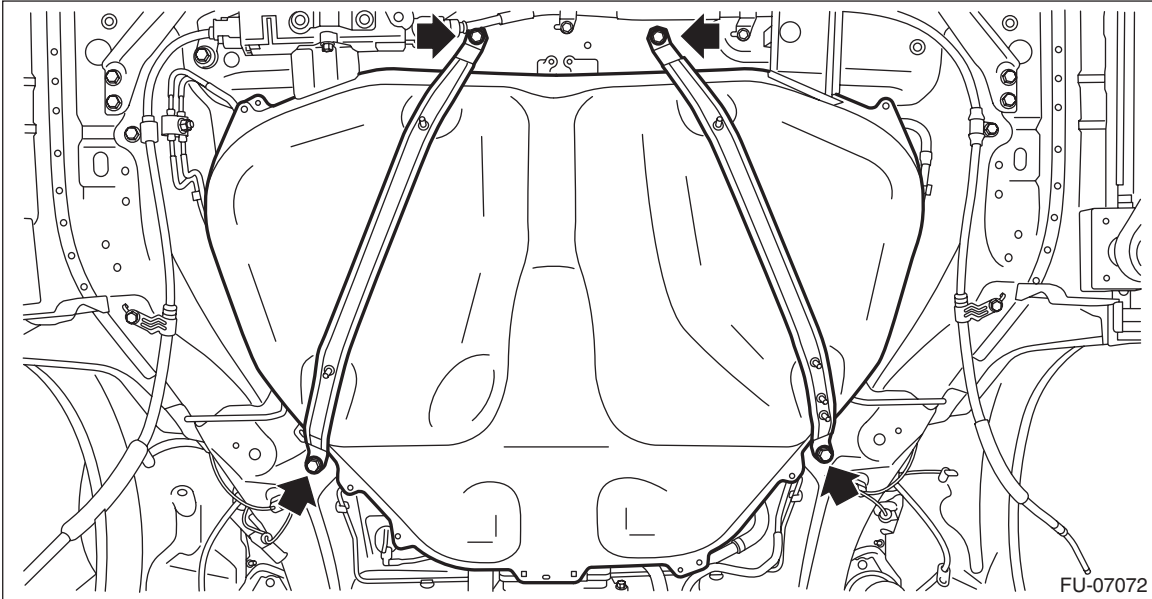

Fuel Tank

2) Correctly insert the fuel filler hose to the spool, and then install the clamp as shown.

Tightening torque:

2.5 N·m (0.3 kgf·m, 1.8 ft·lb)

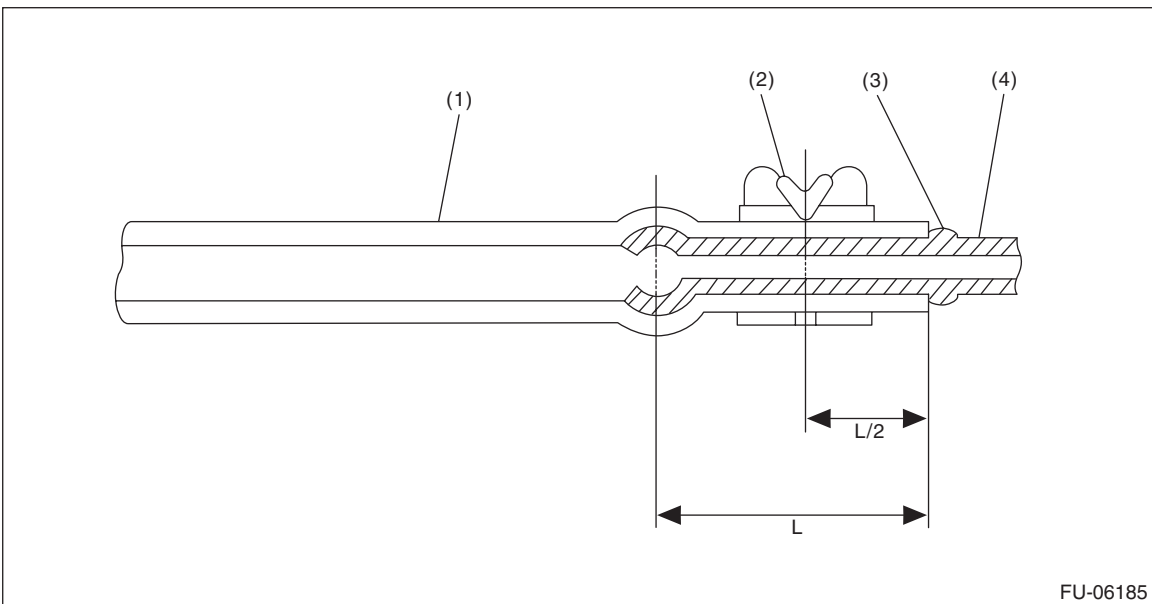
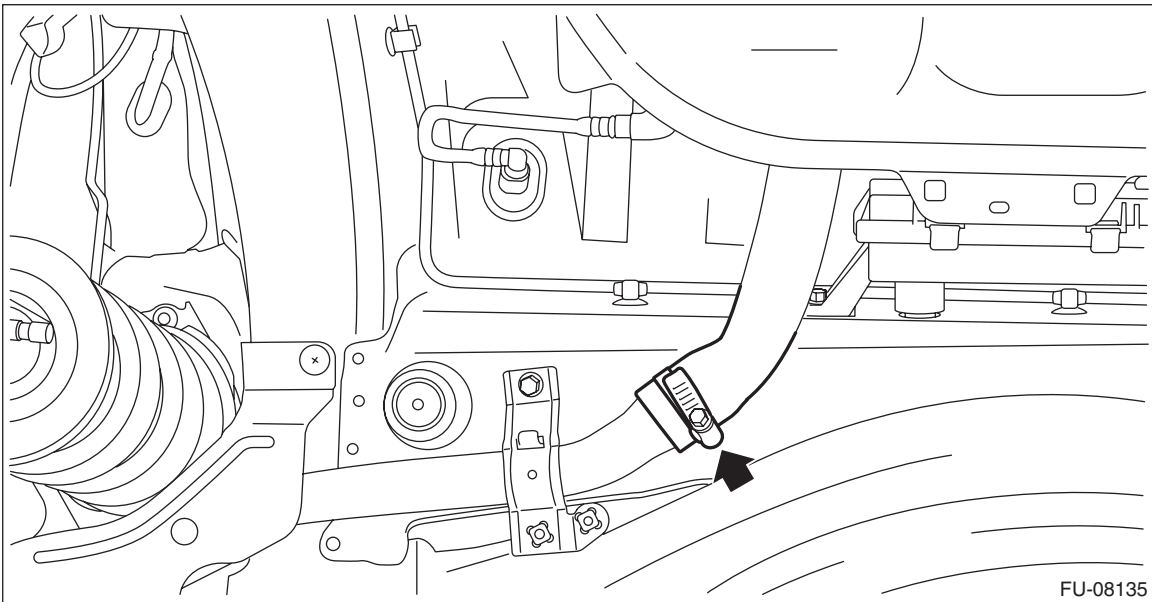

- (1) Hose
- (2) Clamp

(3) Spool

(4) Pipe

Fuel Tank

FUEL INJECTION (FUEL SYSTEMS)

3) Connect the quick connector of the circulate tube to the evaporation pipe as shown in the figure.

CAUTION:

- Check that there is no damage or dust on the quick connector. If necessary, clean the seal surface of the pipe.
- Make sure that the quick connector is securely connected.

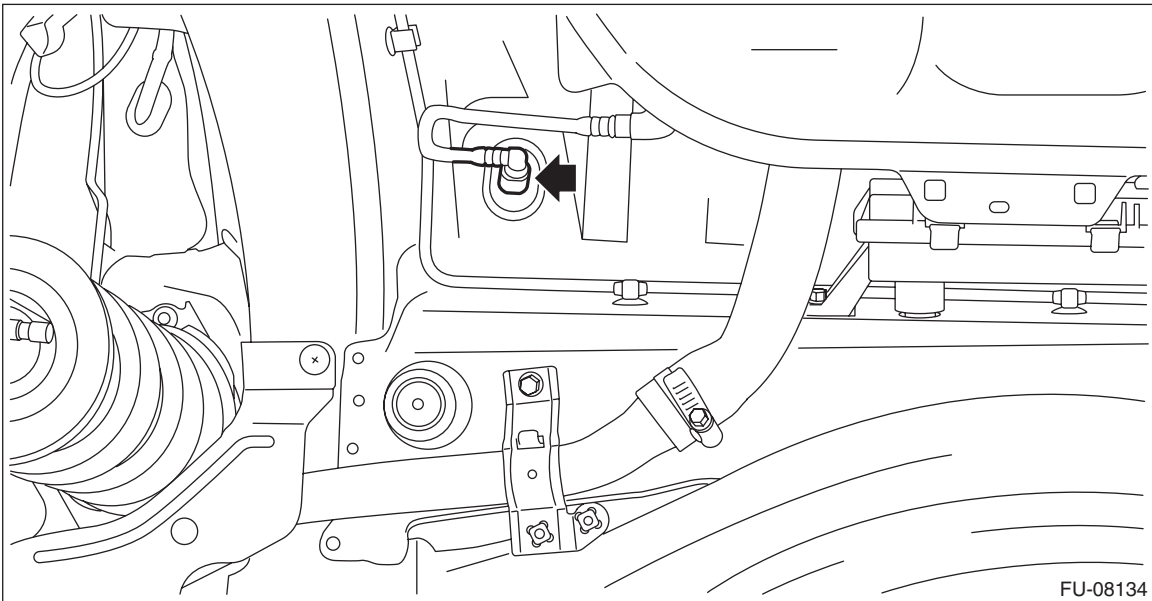
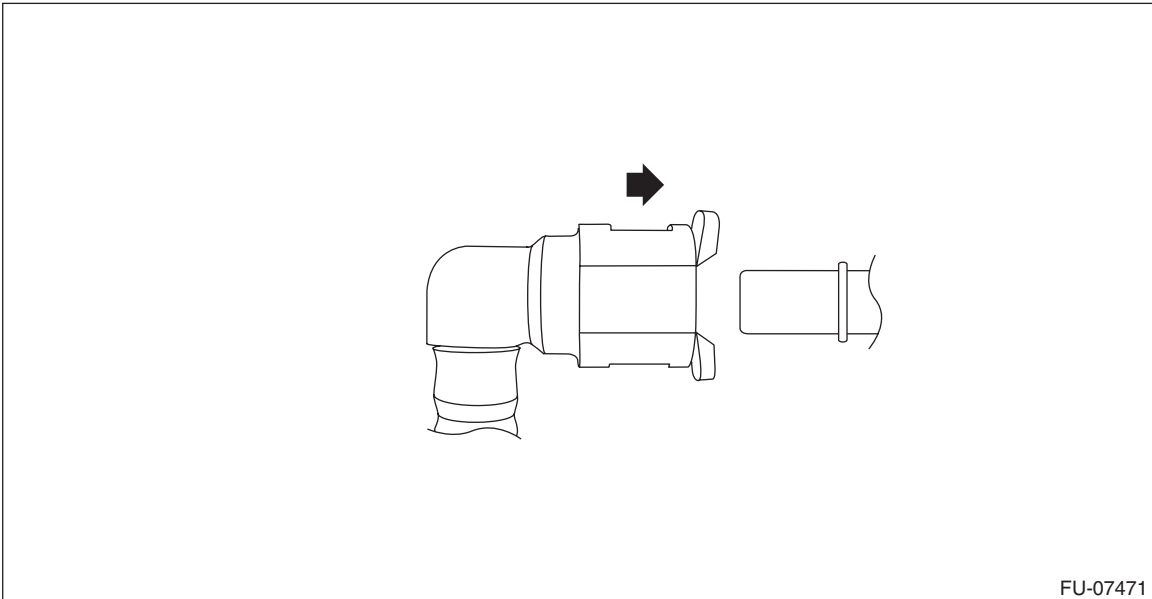

4) Connect the air vent hose to fuel tank.

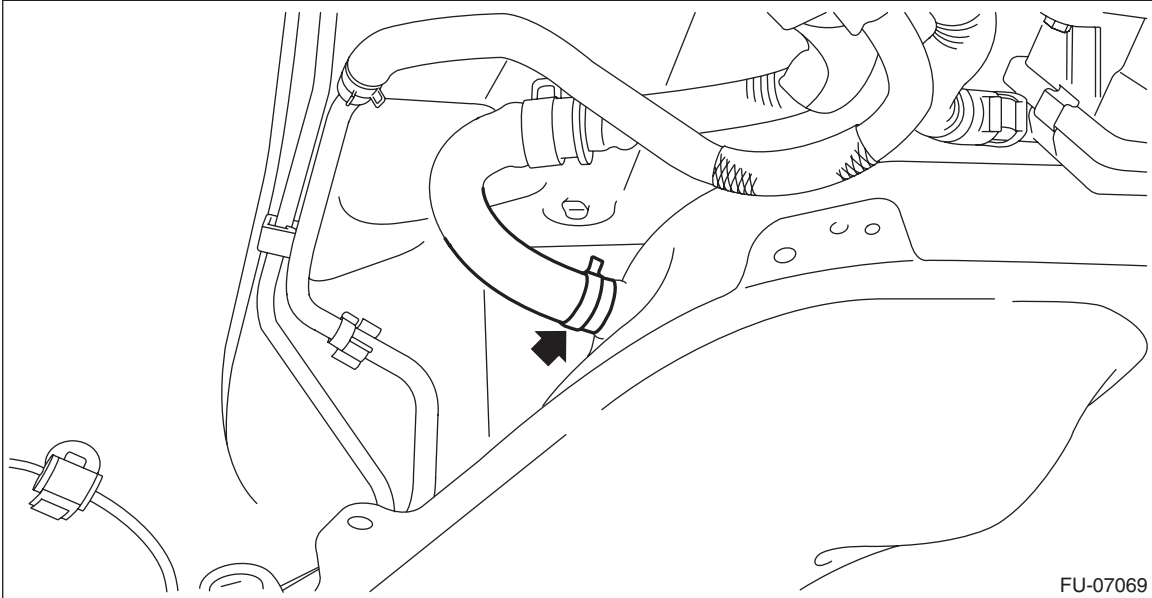

5) Move the fuel tank so that the distance between the center of the positioning hole for the body (A) and the front end of the fuel tank flange (B) becomes L, and tighten the bolts of the fuel tank bands in the sequence shown in the figure.

CAUTION:

To prevent the fuel tank from damage, after tightening the bolts of the fuel tank bands, make sure that the distance between the center of the positioning hole for the body (A) and the front end of the fuel tank flange (B) is L.

Distance L: Center of the positioning hole for the body (A) — Front end of the fuel tank flange (B)
 14.5 mm (0.571 in) or less

Tightening torque:
 33 N·m (3.4 kgf·m, 24.3 ft·lb)

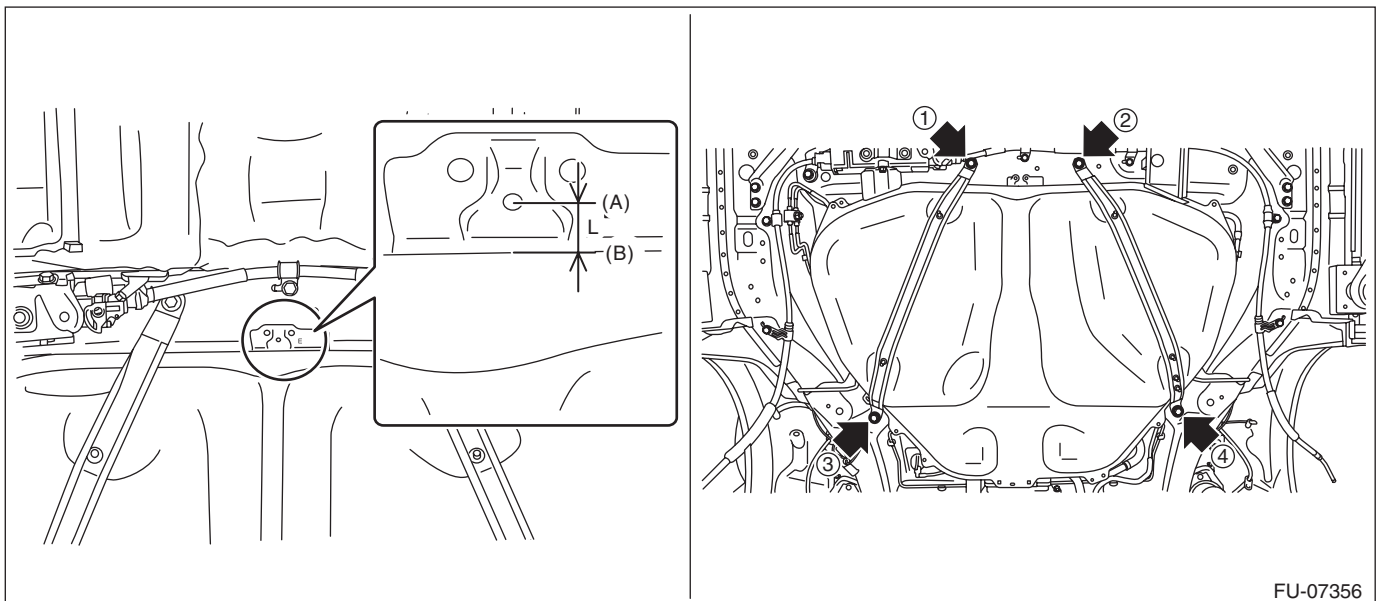

Fuel Tank

FUEL INJECTION (FUEL SYSTEMS)

6) Install the rear suspension assembly.

WARNING:

A helper is required to perform this work.

- (1) Support the rear differential with the transmission jack.
- (2) Support the rear suspension assembly and install the rear suspension assembly to the body.

Tightening torque:

T1: 70 N·m (7.1 kgf-m, 51.6 ft-lb)

T2: 200 N·m (20.4 kgf-m, 147.5 ft-lb)

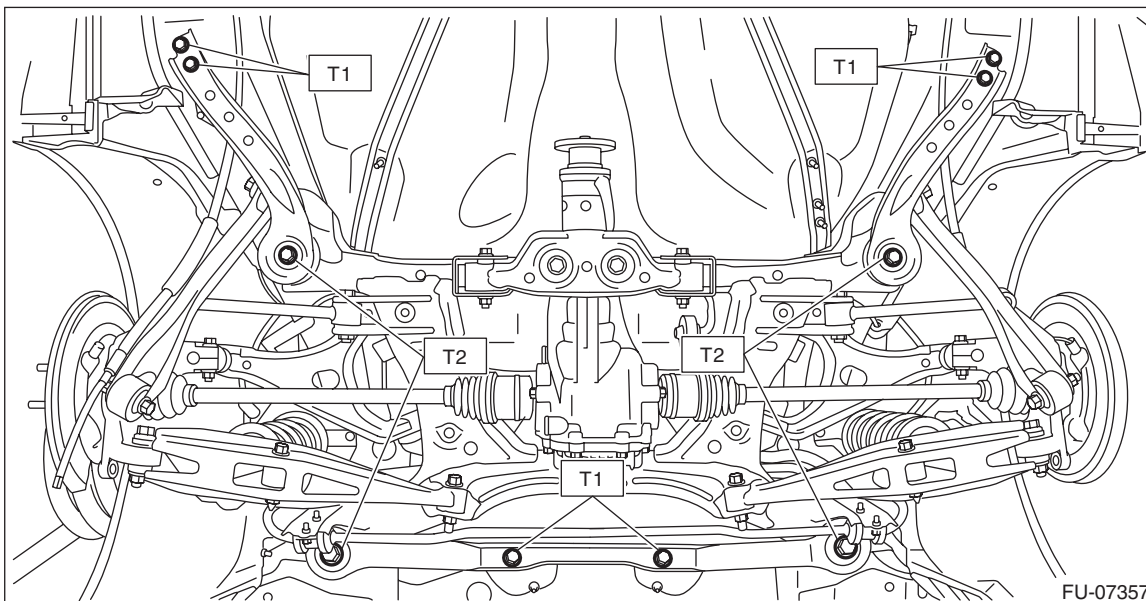

(3) Install the rear shock absorber to the rear suspension arm.

NOTE:

Use a new self-locking nut.

Tightening torque:

120 N·m (12.2 kgf-m, 88.5 ft-lb)

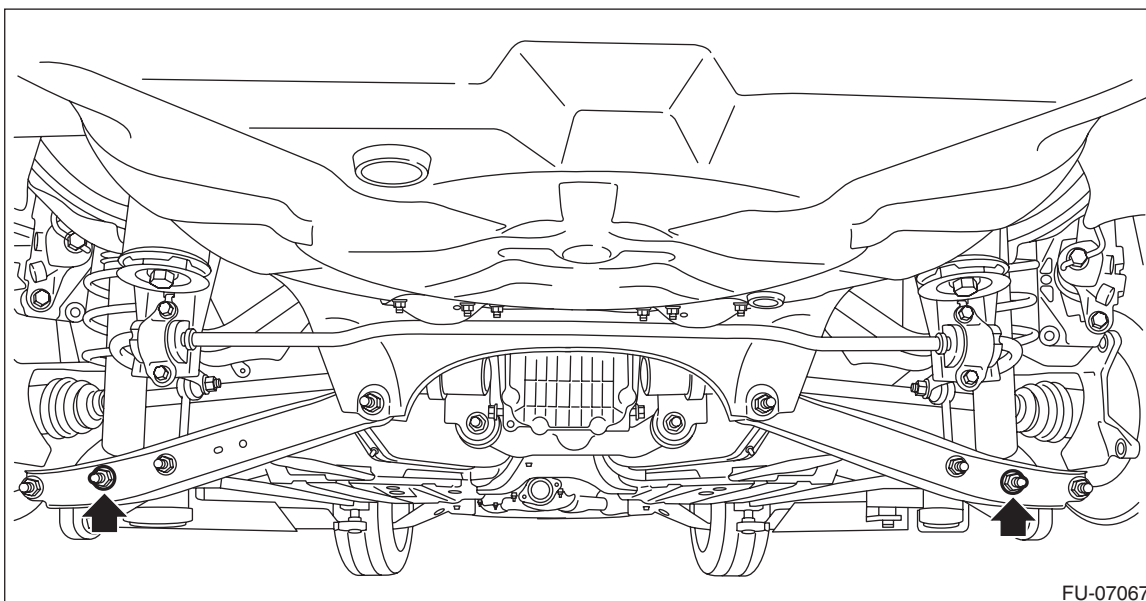

7) Install the heat shield cover.

Tightening torque:

18 N·m (1.8 kgf·m, 13.3 ft·lb)

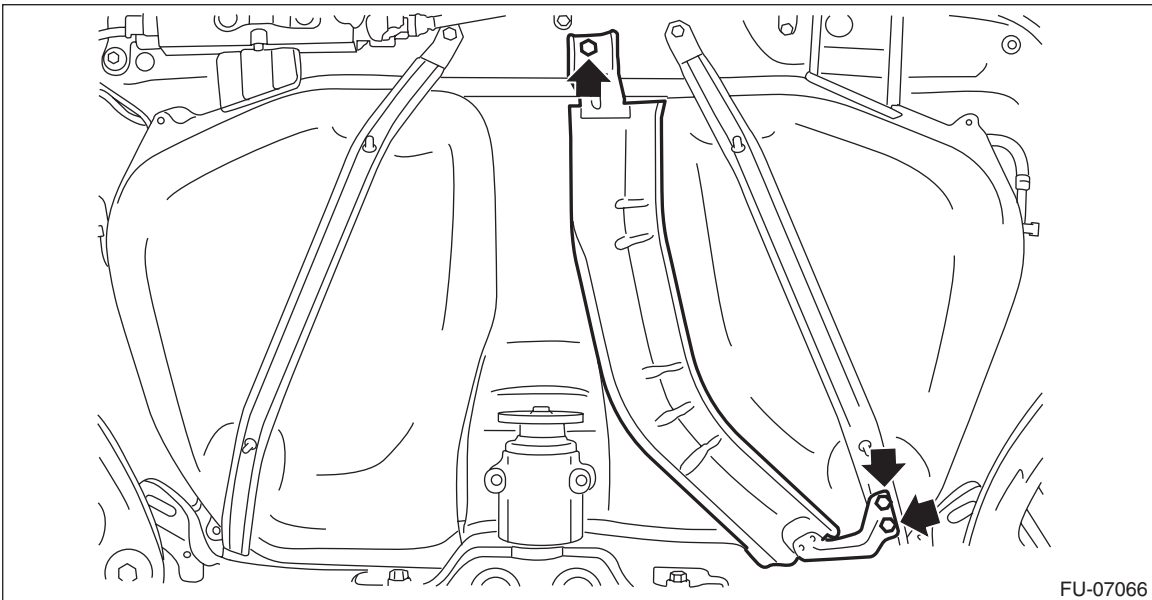

FU-07066

8) Install the bolts (A) and nuts (B) which secure the fuel tank protector.

NOTE:

Use a new self-locking nut.

Tightening torque:

Nut (B): 9 N·m (0.9 kgf·m, 6.6 ft·lb)

Bolt (A): 18 N·m (1.8 kgf·m, 13.3 ft·lb)

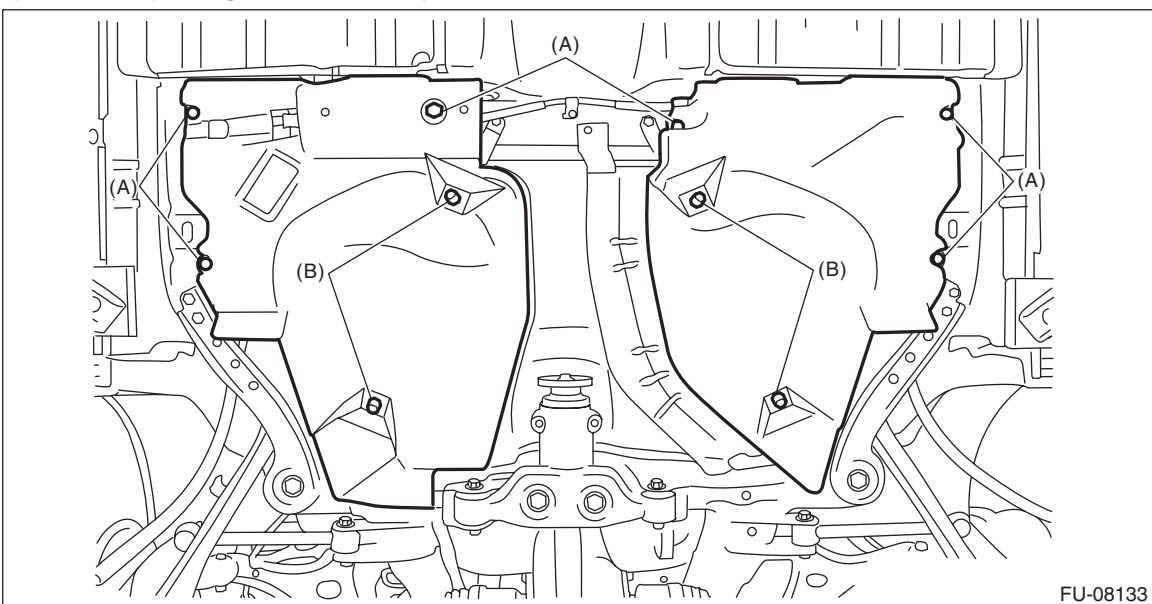

FU-08133

9) Install the propeller shaft. <Ref. to DS-11, INSTALLATION, Propeller Shaft.>

10) Install the rear exhaust pipe and muffler. <Ref. to EX(H4DO)-14, INSTALLATION, Rear Exhaust Pipe.>
<Ref. to EX(H4DO)-17, INSTALLATION, Muffler.>

11) Lower the vehicle.

12) Connect the parking brake cable to the parking brake assembly. <Ref. to PB-15, INSTALLATION, Parking Brake Assembly (Rear Disc Brake).>

Fuel Tank

FUEL INJECTION (FUEL SYSTEMS)

13) Install the rear disc brake assembly.

Tightening torque:

66 N·m (6.7 kgf·m, 48.7 ft·lb)

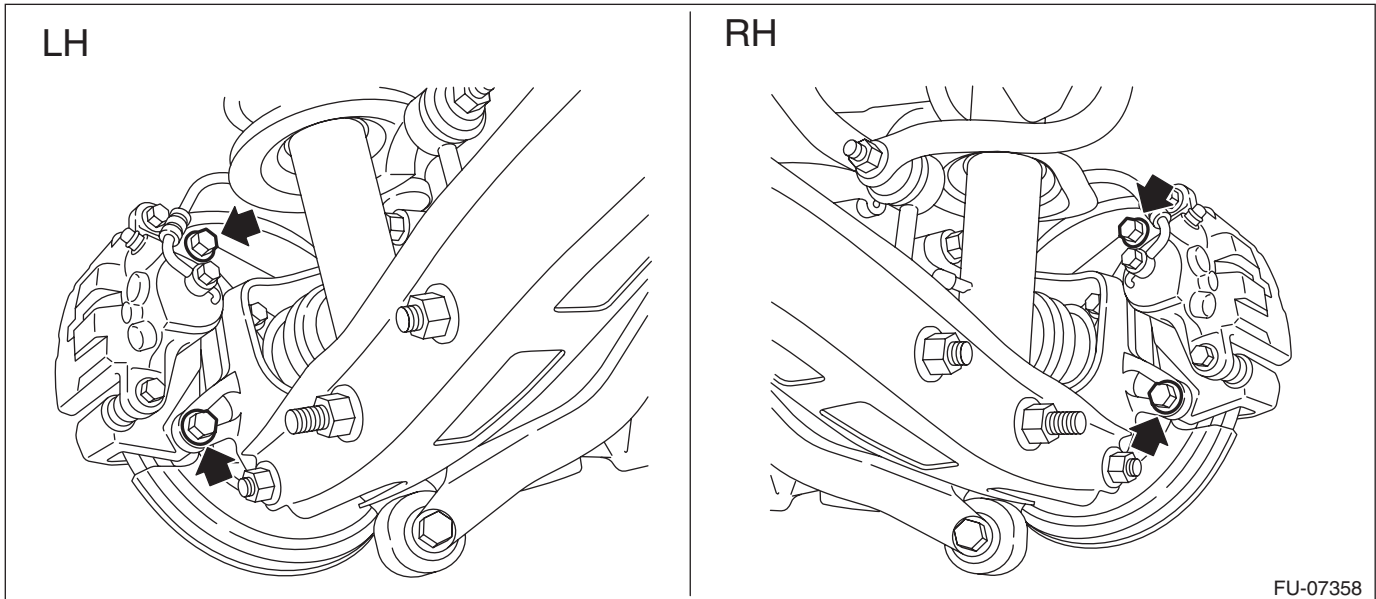

14) Install the rear brake hose bracket to the rear housing.

Tightening torque:

33 N·m (3.4 kgf·m, 24.3 ft·lb)

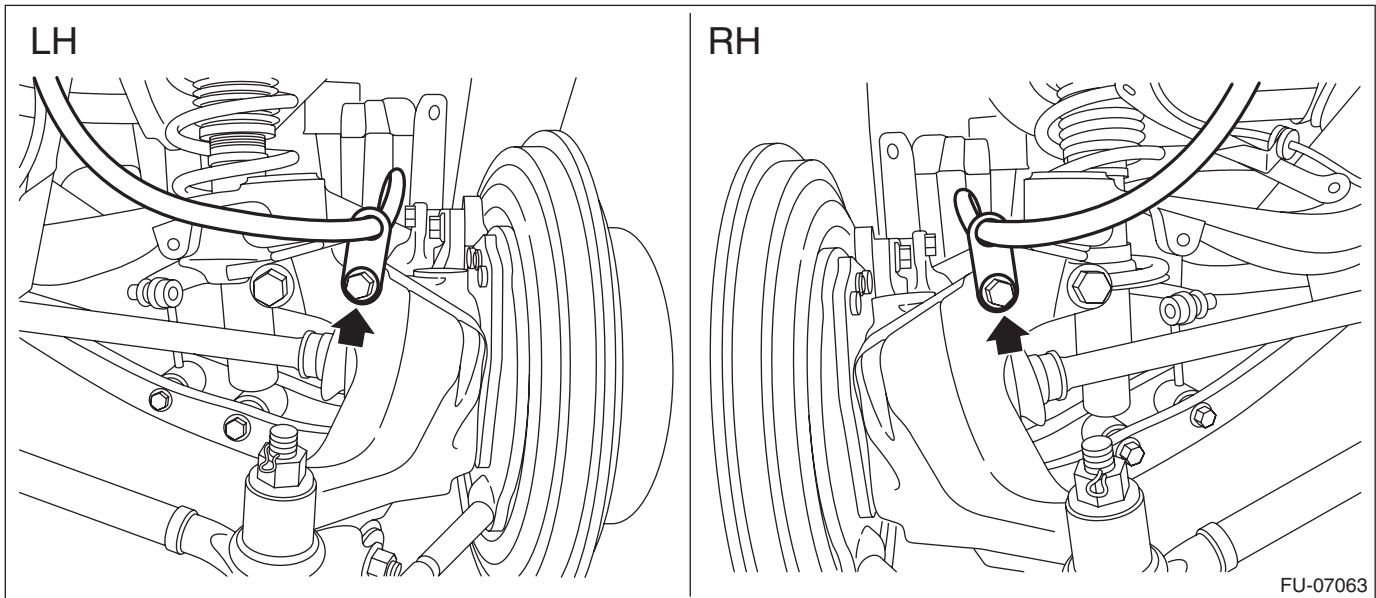

15) Install the rear ABS wheel speed sensor harness bracket to the upper arm.

NOTE:

Prevent the harness identification (line) from being twisted when installing. <Ref. to VDC-2, SPECIFICATION, General Description.>

Tightening torque:

7.5 N·m (0.8 kgf-m, 5.5 ft-lb)

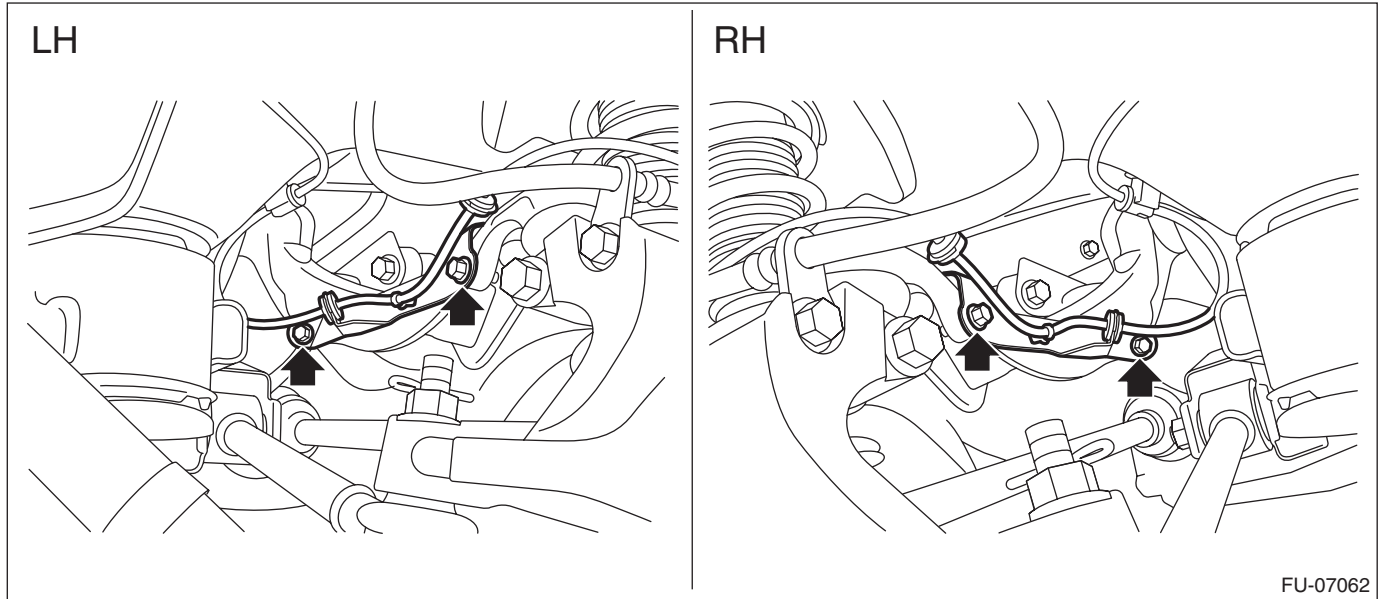

16) Attach the rear ABS wheel speed sensor to the rear housing.

NOTE:

Prevent the harness identification (line) from being twisted when installing. <Ref. to VDC-2, SPECIFICATION, General Description.>

Tightening torque:

7.5 N·m (0.8 kgf-m, 5.5 ft-lb)

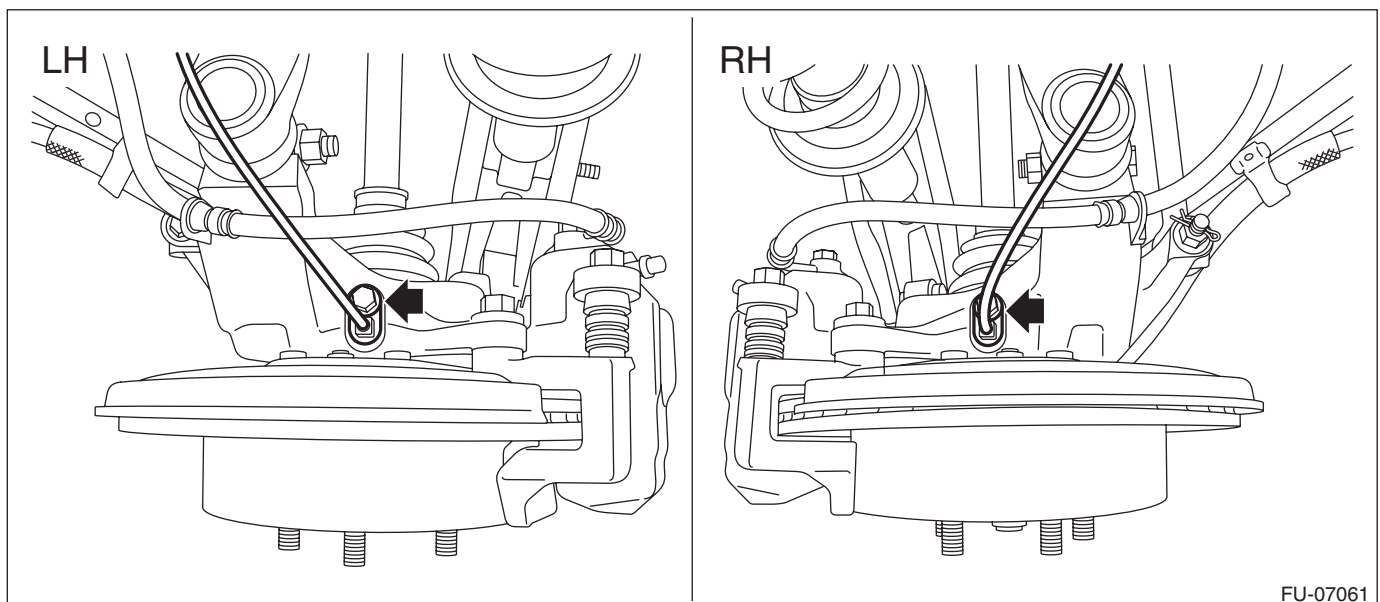

17) Install the rear wheels.

Tightening torque:

120 N·m (12.2 kgf-m, 88.5 ft-lb)

Fuel Tank

FUEL INJECTION (FUEL SYSTEMS)

18) Connect the quick connector of the fuel delivery tube. <Ref. to FU(H4DO)-166, INSTALLATION, Fuel Delivery and Evaporation Lines.>

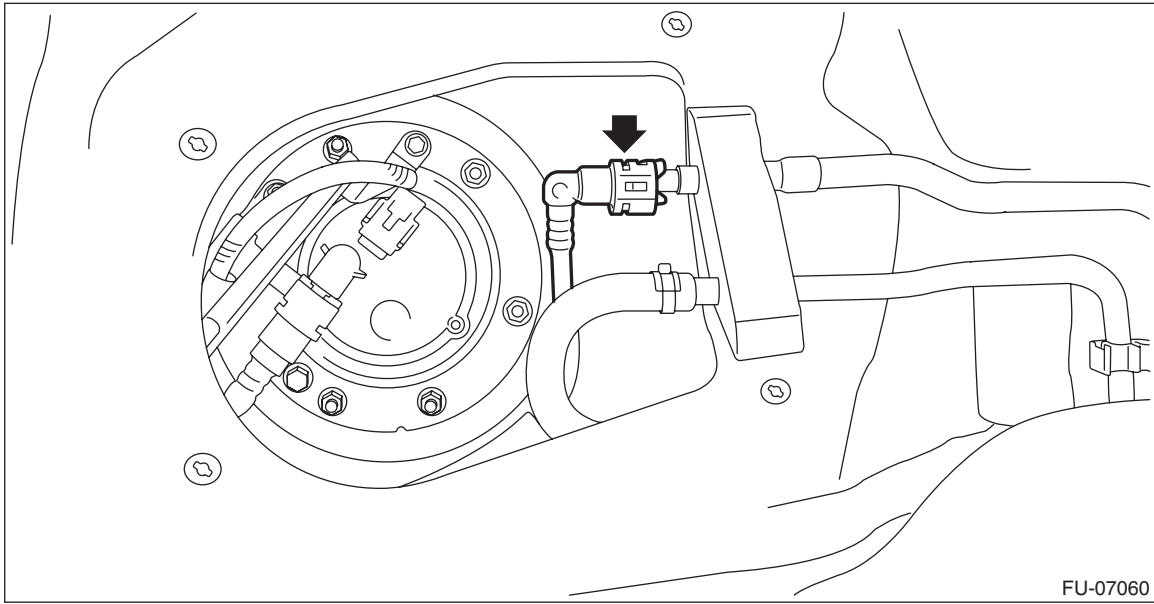

19) Install the service hole cover of fuel sub level sensor.

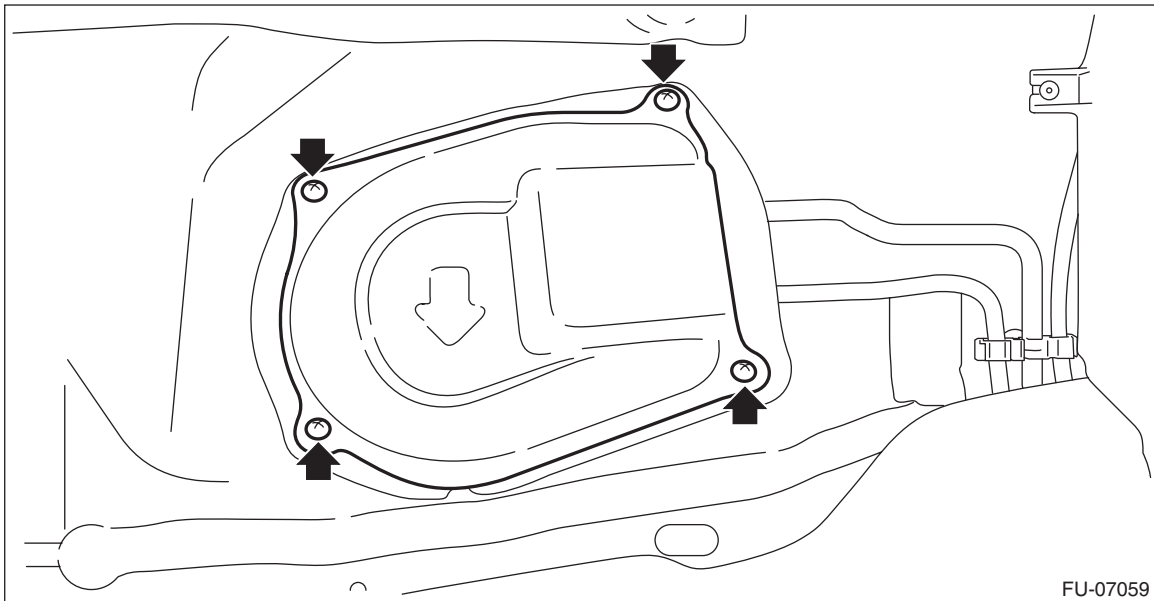

Fuel Tank

20) Attach the service hole cover of the fuel pump, and attach the connector and clip.

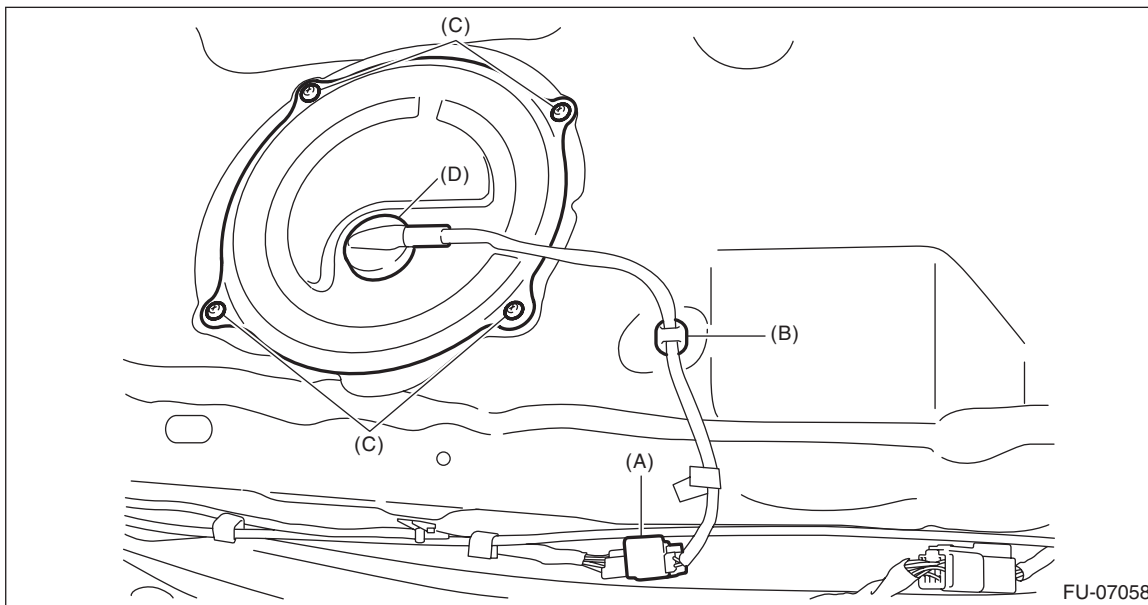

- (A) Connector
- (B) Clip
- (C) Screw
- (D) Grommet

21) Set the floor mat (C), and install clips (A) and seat cushion hooks (B).

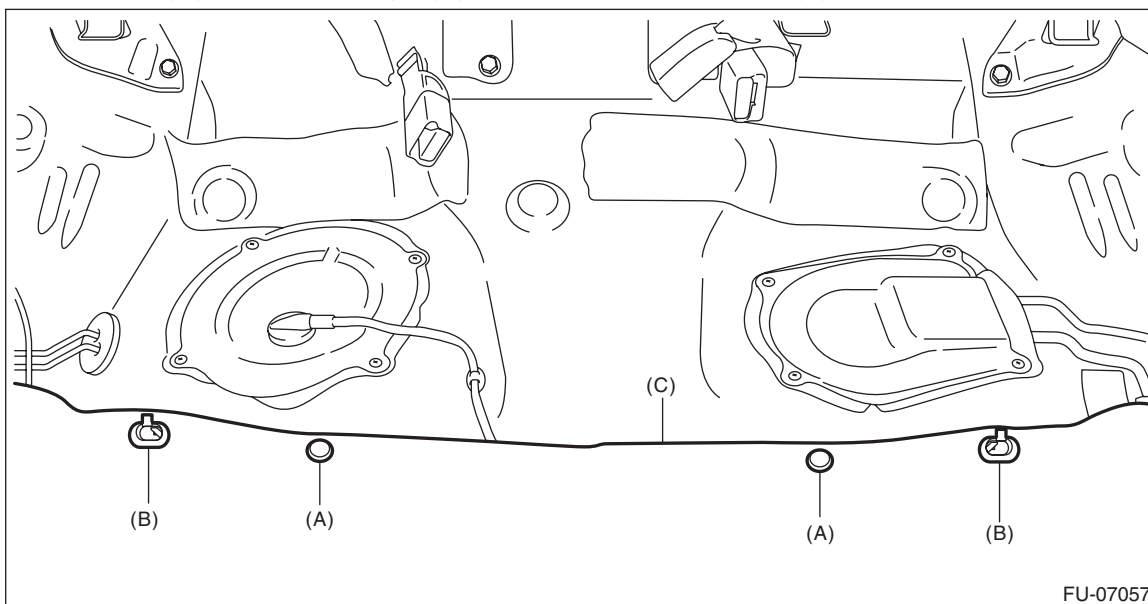

22) Install the rear seat cushion. <Ref. to SE-49, INSTALLATION, Rear Seat.>

Fuel Tank

FUEL INJECTION (FUEL SYSTEMS)

23) Connect the battery ground terminal.

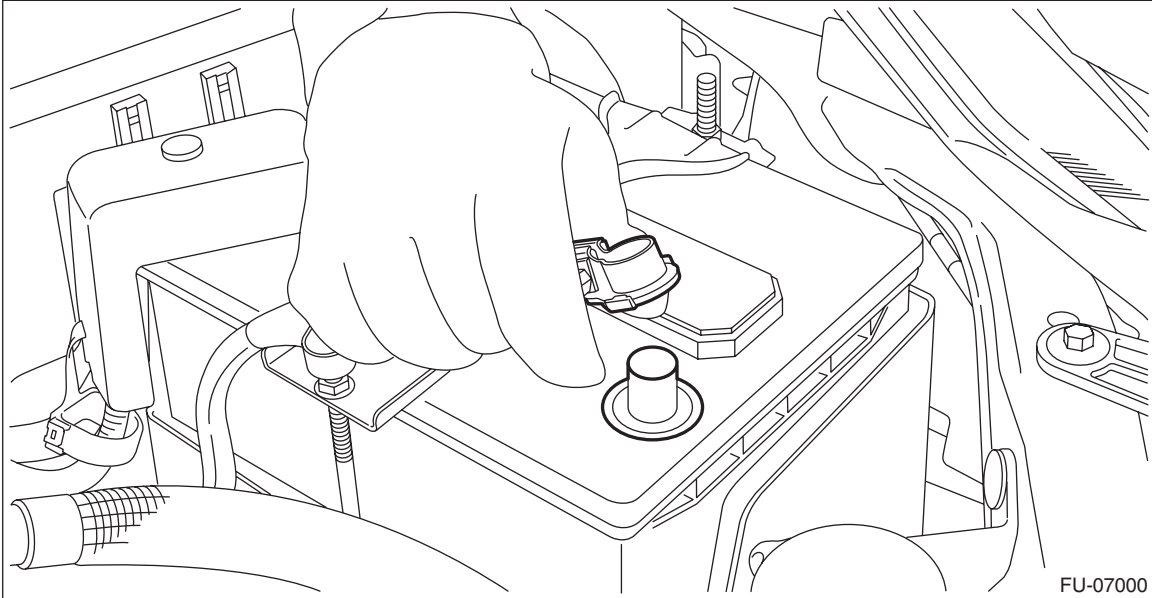

24) Inspect the wheel alignment and adjust if necessary.

C: INSPECTION

- 1) Check that the fuel tank and fuel pipe have no deformation, cracks and other damages.
- 2) Check that the fuel hose and tube have no cracks, damage or loose part.