

Intake Manifold

FUEL INJECTION (FUEL SYSTEMS)

3. Intake Manifold

A: REMOVAL

- 1) Release the fuel pressure. <Ref. to FU(H4DO)-109, RELEASING OF FUEL PRESSURE, PROCEDURE, Fuel.>
- 2) Disconnect the ground cable from battery.

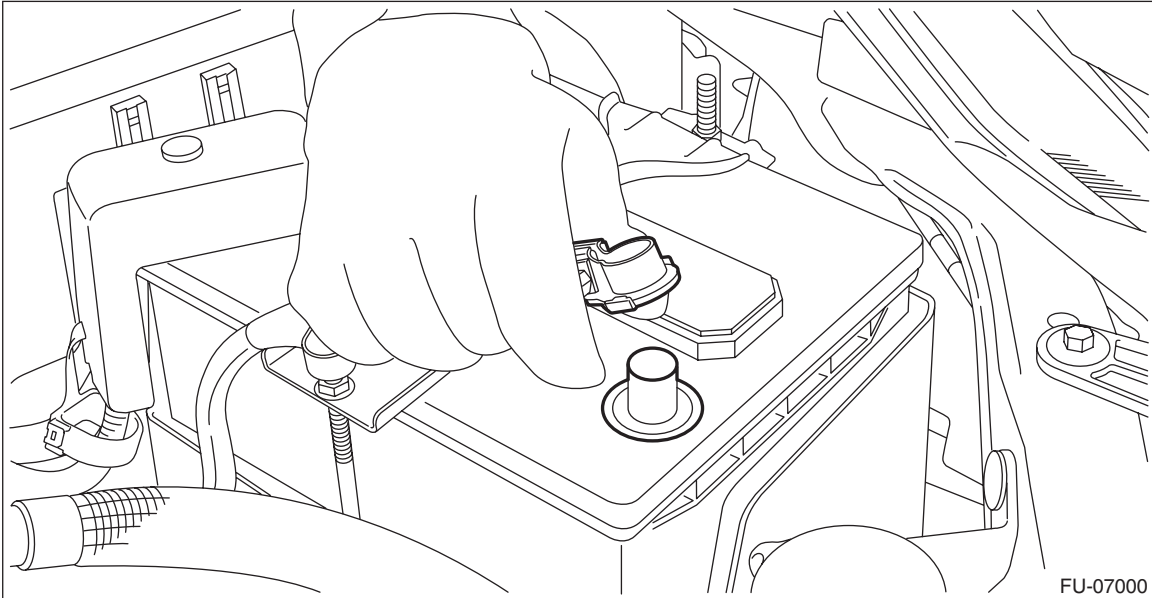

- 3) Open the fuel filler lid and remove the fuel filler cap.
- 4) Lift up the vehicle.
- 5) Remove the under cover. <Ref. to EI-33, REMOVAL, Front Under Cover.>
- 6) Drain approximately 3.0 L (3.2 US qt, 2.6 Imp qt) of coolant. <Ref. to CO(H4DO)-14, DRAINING OF ENGINE COOLANT, REPLACEMENT, Engine Coolant.>
- 7) Remove the clip (A) from the air intake boot.
- 8) Loosen the clamp (B) connecting the air intake boot and air cleaner case (rear).
- 9) Loosen the clamp (C) which connects the air intake boot and throttle body.

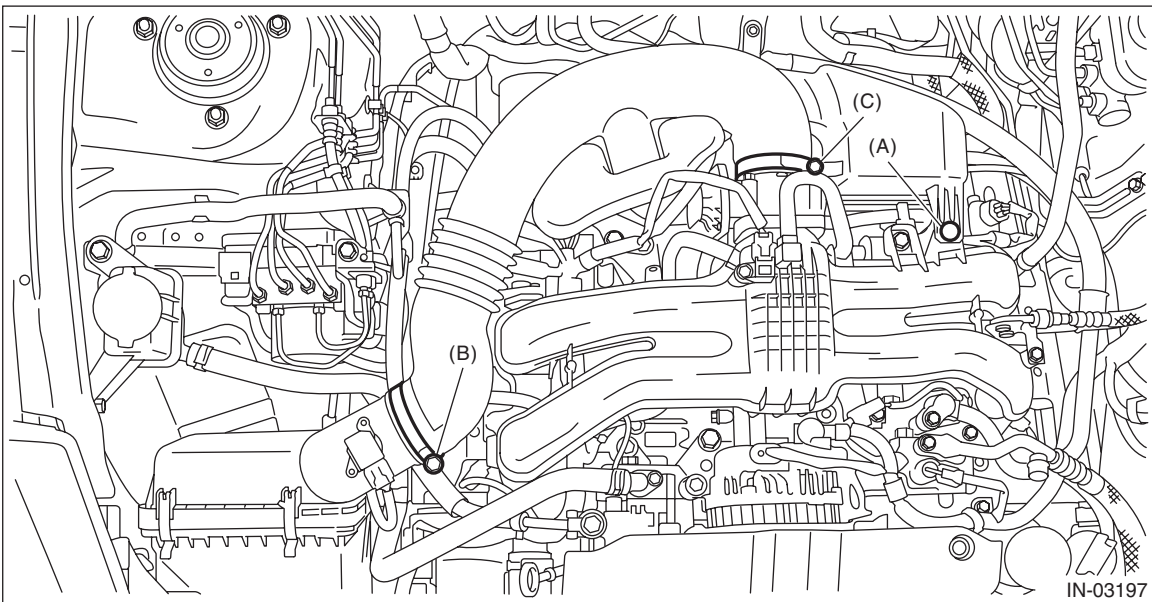

Intake Manifold

FUEL INJECTION (FUEL SYSTEMS)

- 10) Remove the air intake boot from the throttle body, and move it to the left side wheel apron.

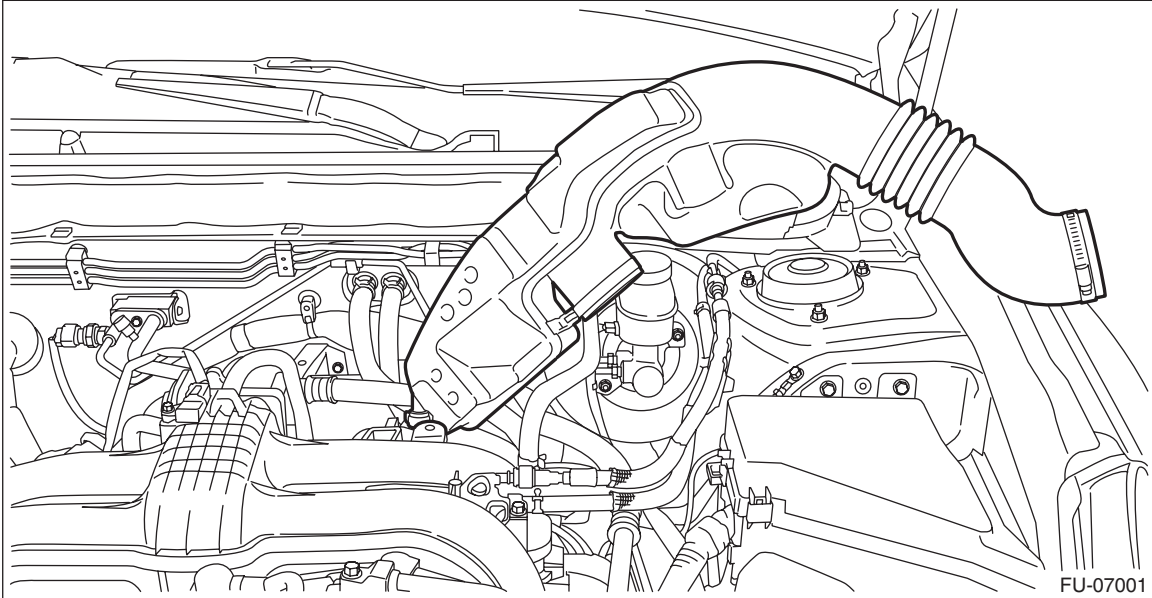

- 11) Disconnect the preheater hose from throttle body.

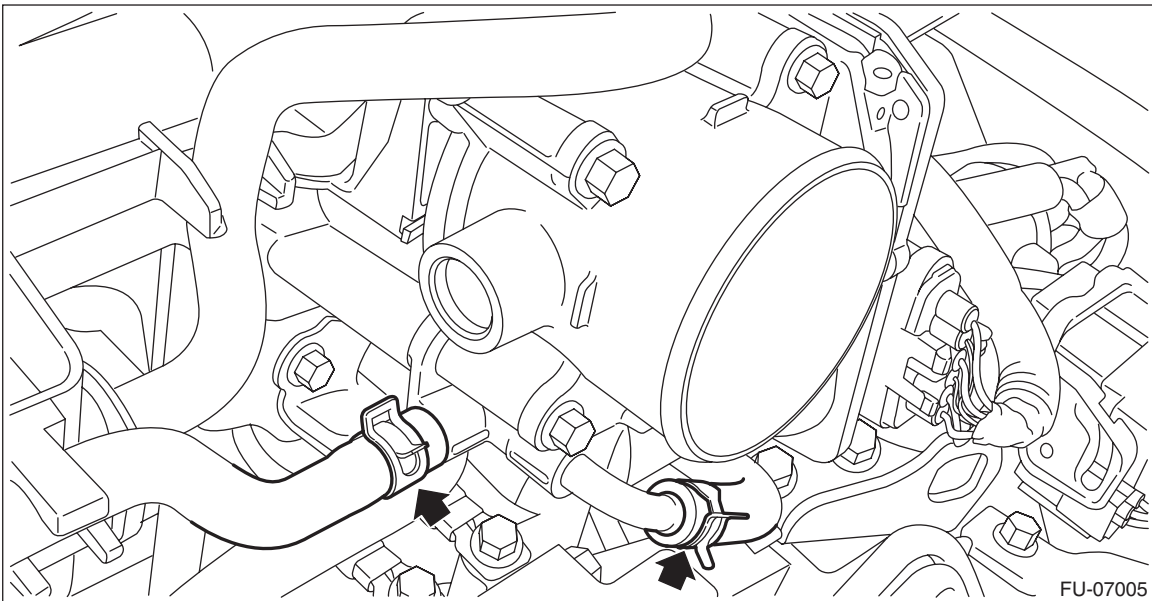

- 12) Disconnect the connector (A) from the purge control solenoid valve.
13) Loosen the bolt (B) which secures the EGR pipe to the intake manifold.

Intake Manifold

FUEL INJECTION (FUEL SYSTEMS)

- 14) Remove the nut (C) which holds EGR pipe from the water pipe assembly.

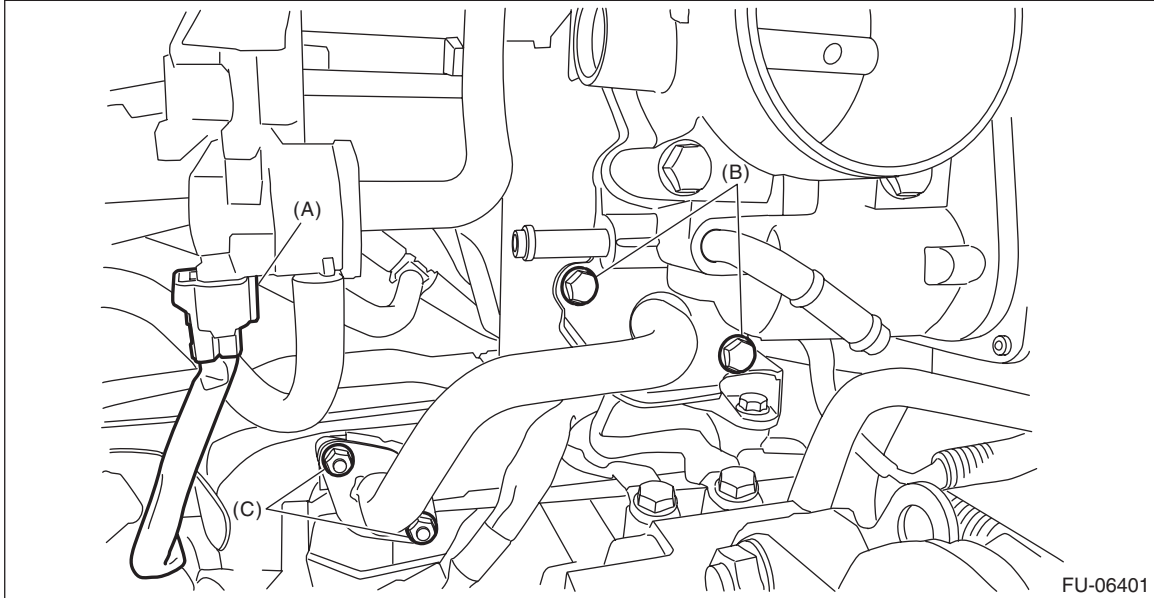

- 15) Disconnect the PCV hose (A) from intake manifold.
16) Disconnect the connector (B) from manifold absolute pressure sensor.
17) Disconnect the connector (C) from the throttle position sensor.

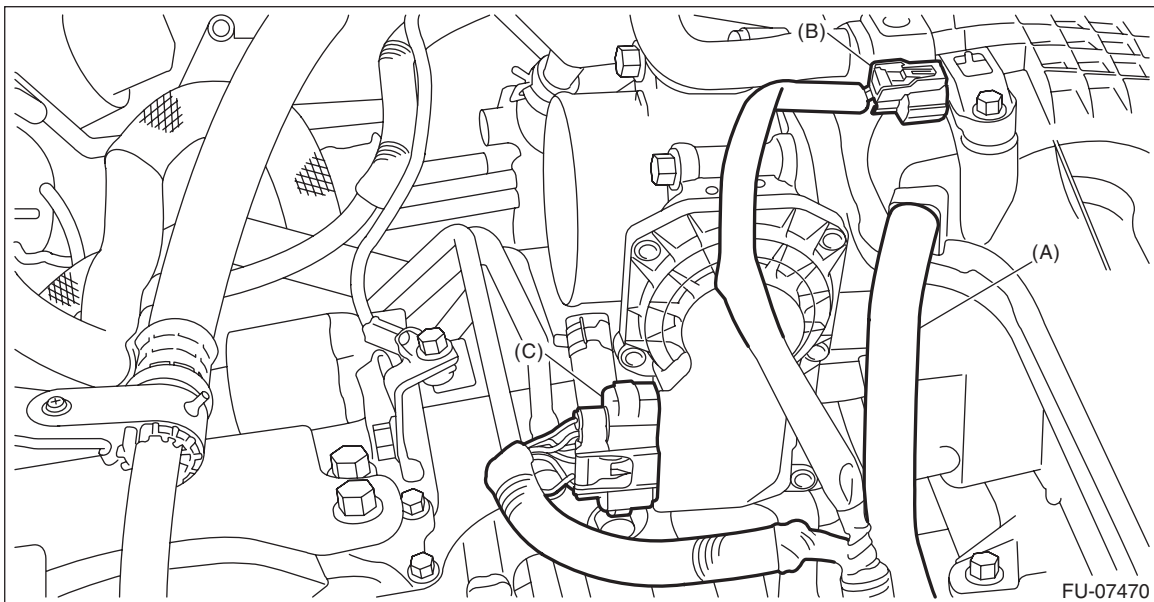

Intake Manifold

FUEL INJECTION (FUEL SYSTEMS)

18) Disconnect the brake booster vacuum hose from the intake manifold.

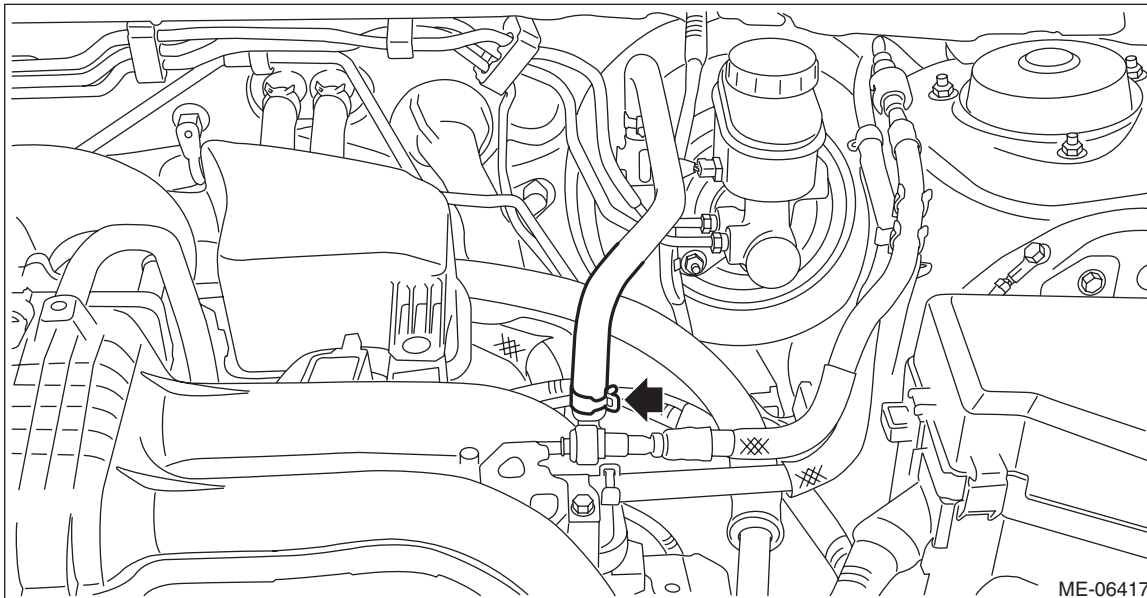

19) Disconnect the connector (A) from the mass air flow and intake air temperature sensor, and remove the clip (B) which holds the mass air flow and intake air temperature sensor harness.

20) Remove the suction hose (C) from the air cleaner case (rear).

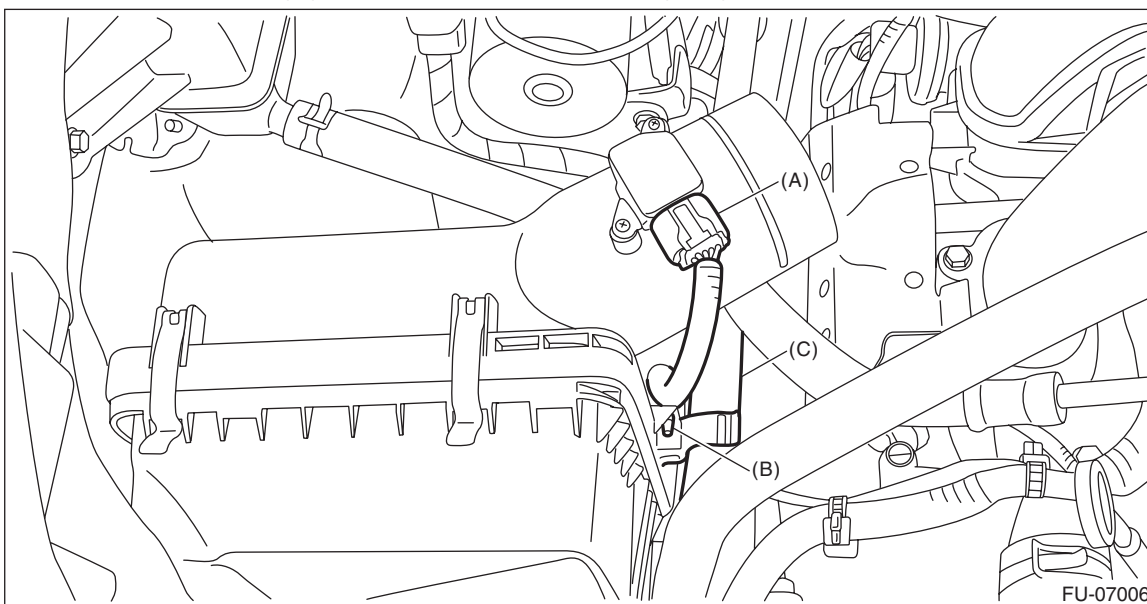

Intake Manifold

FUEL INJECTION (FUEL SYSTEMS)

21) Remove the air cleaner case (rear).

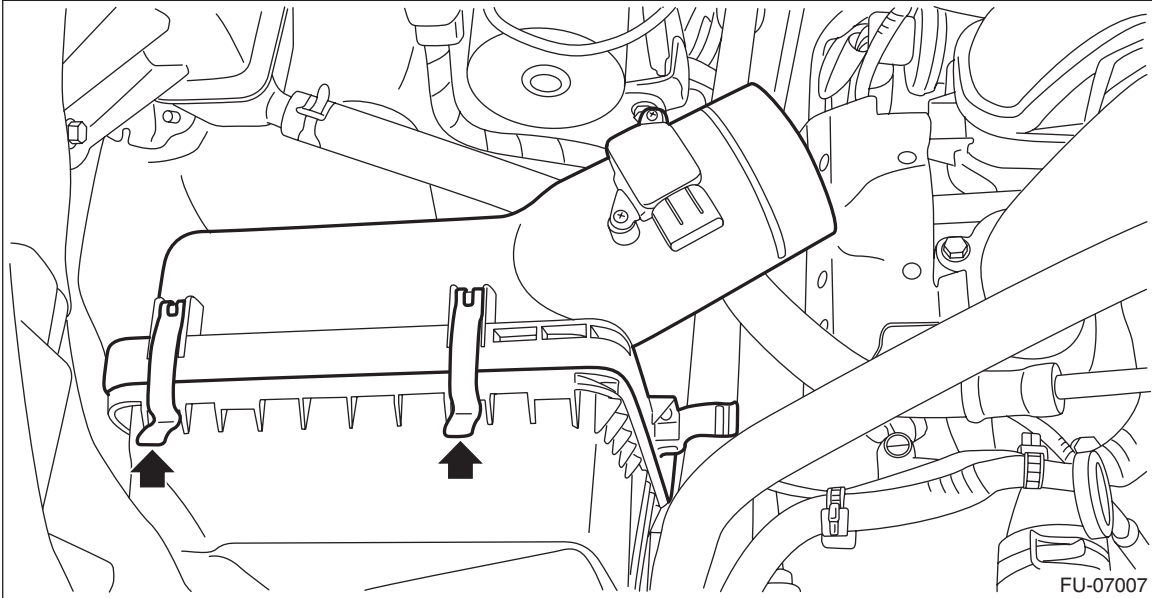

22) Remove the intake manifold protector RH.

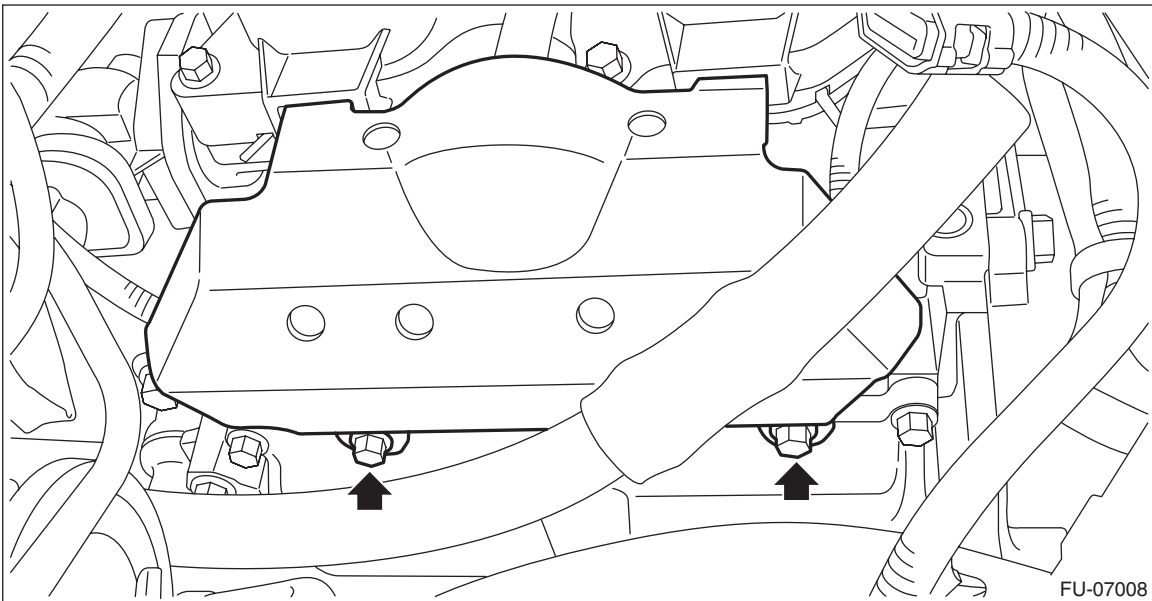

23) Disconnect the fuel delivery pipe from the fuel pipe RH.

CAUTION:

- Be careful not to spill fuel.
- Catch the fuel from the pipes using a container or cloth.

NOTE:

Disconnect the quick connector as shown in the figure.

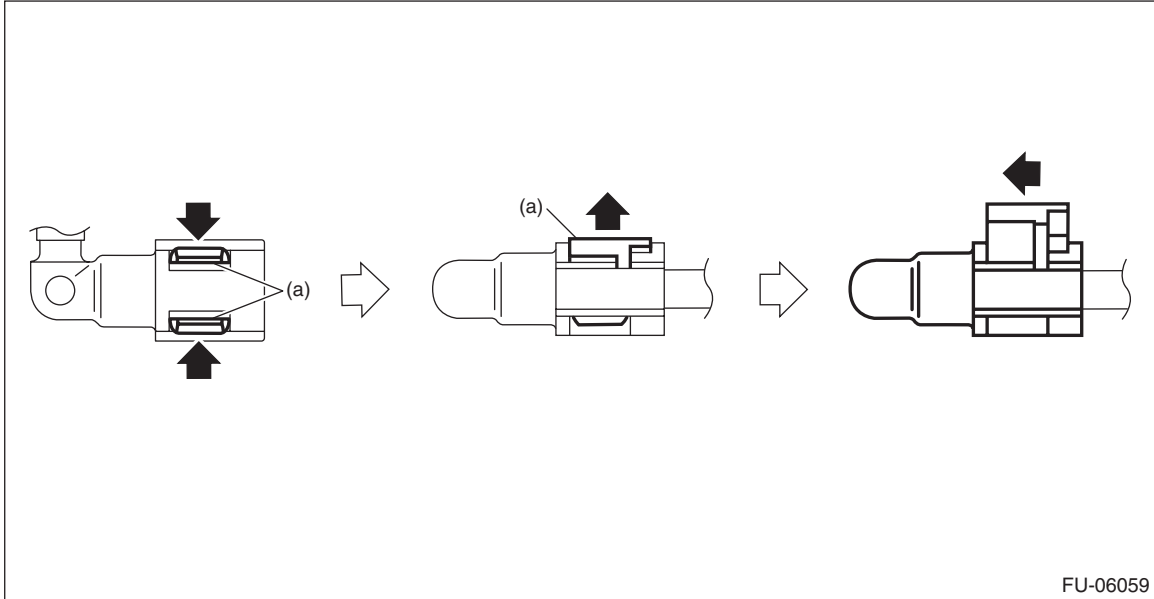

(a) Slider

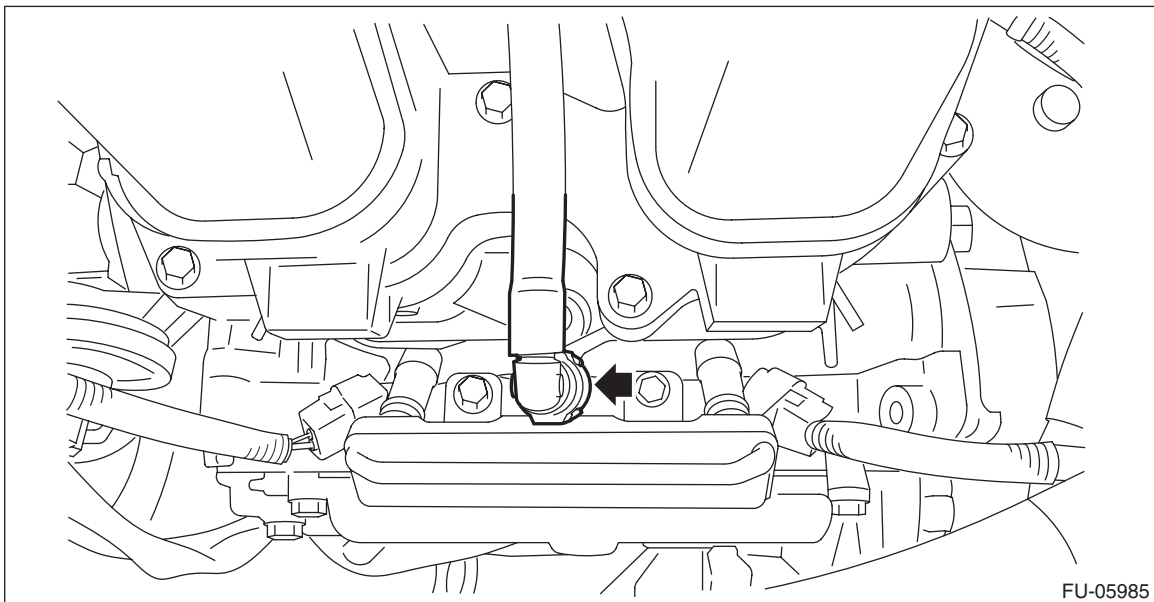

Intake Manifold

FUEL INJECTION (FUEL SYSTEMS)

24) Remove the intake manifold protector LH.

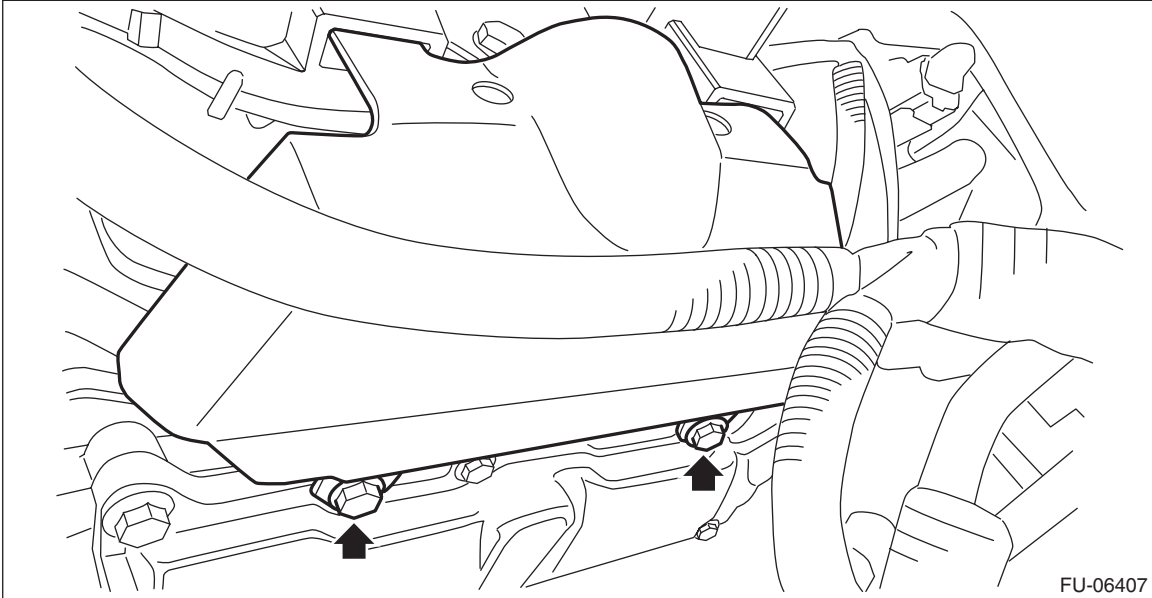

FU-06407

25) Disconnect the fuel delivery pipe from the fuel pipe LH.

CAUTION:

- Be careful not to spill fuel.
- Catch the fuel from the pipes using a container or cloth.

NOTE:

Disconnect the quick connector as shown in the figure.

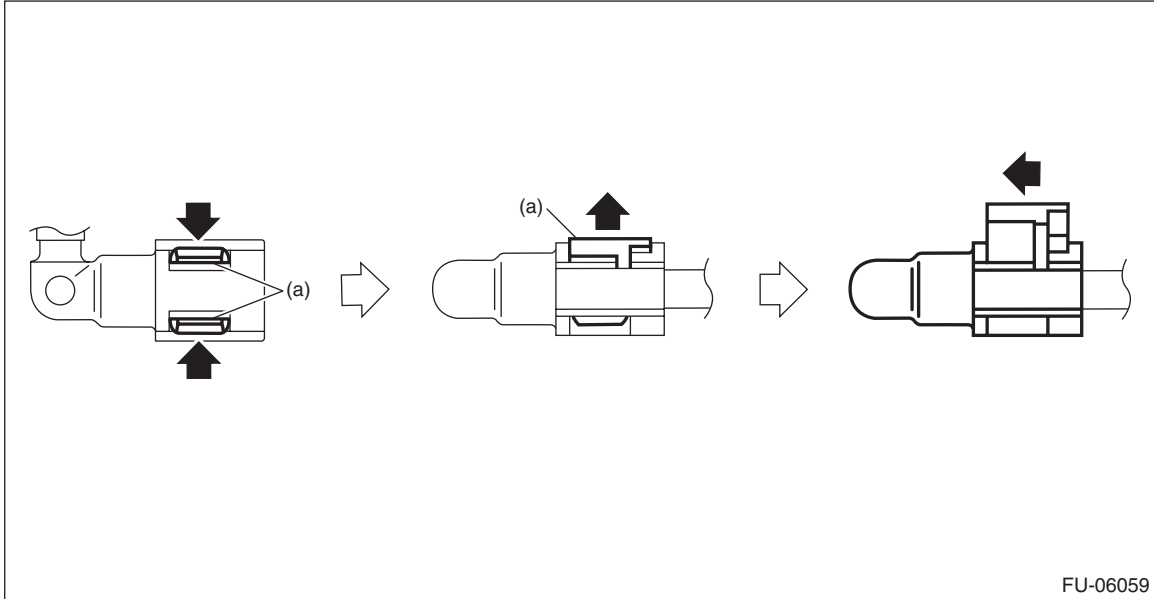

(a) Slider

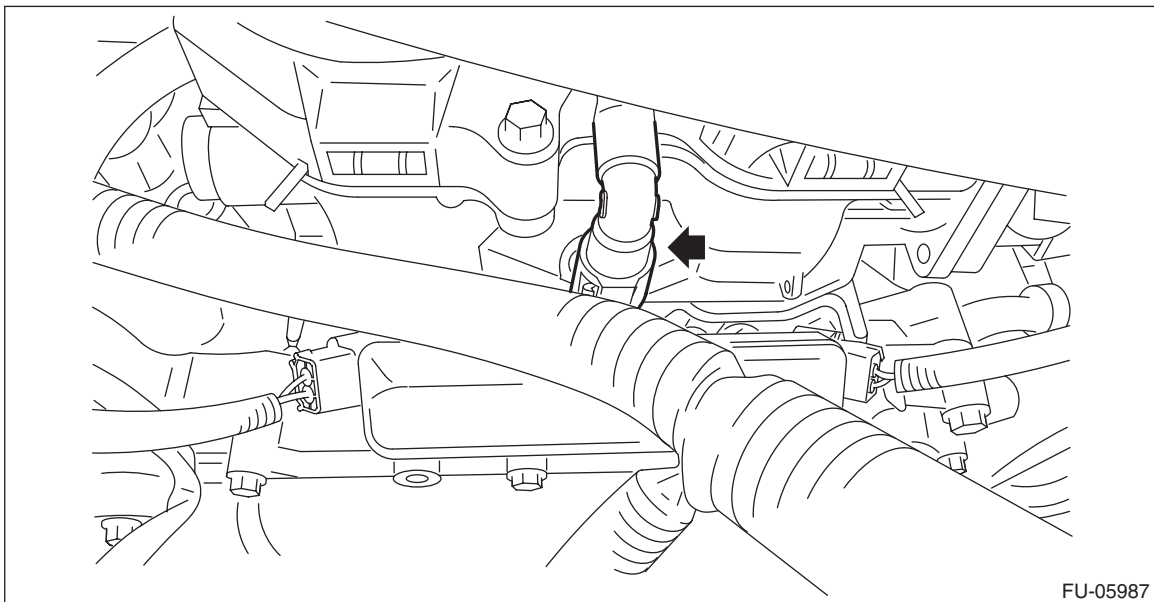

Intake Manifold

FUEL INJECTION (FUEL SYSTEMS)

26) Disconnect the fuel delivery hose (A) and evaporation hose (B).

CAUTION:

- Be careful not to spill fuel.
- Catch the fuel from hoses using a container or cloth.

(1) Attach ST to the fuel delivery pipe and push ST in the direction of arrow mark to disconnect the quick connector of the fuel delivery hose (A).

ST 42099AE000 QUICK CONNECTOR RELEASE

(2) Remove the clip and disconnect the evaporation hose (B) from the evaporation pipe.

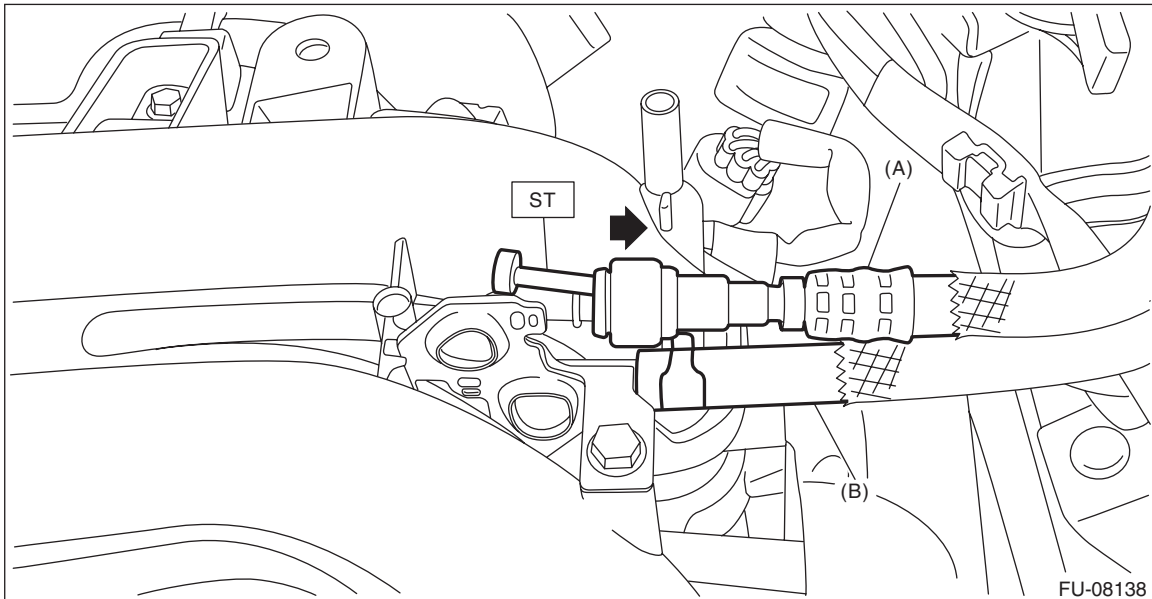

27) Remove the intake manifold from the tumble generator valve assembly.

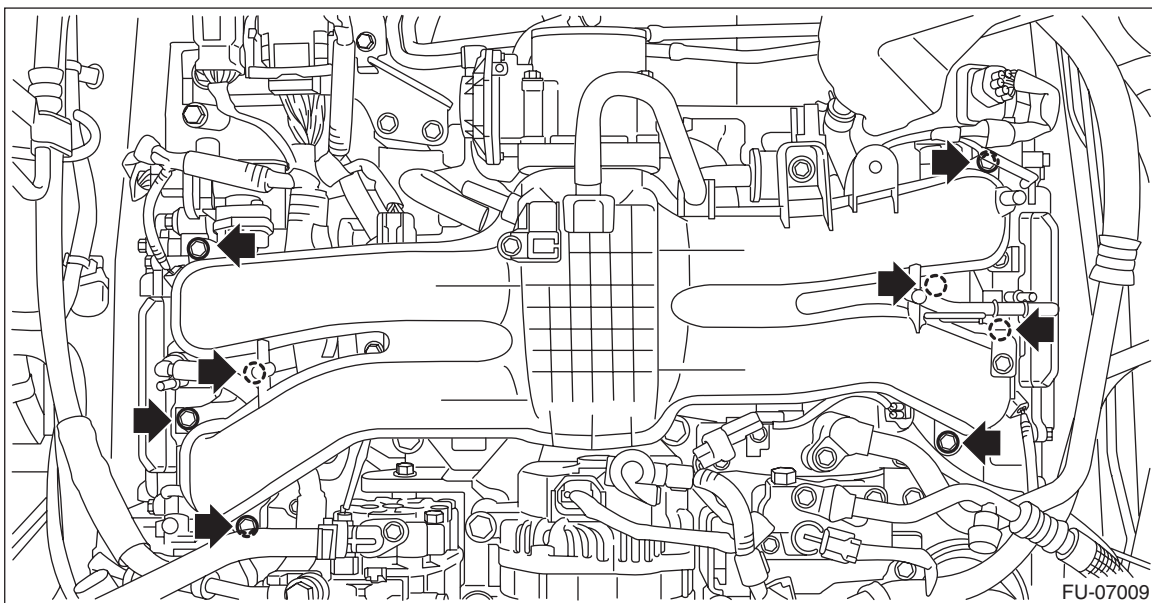

28) Remove the engine wiring harness. <Ref. to FU(H4DO)-42, REMOVAL, Engine Wiring Harness.>

B: INSTALLATION

- 1) Install the engine wiring harness. <Ref. to FU(H4DO)-45, INSTALLATION, Engine Wiring Harness.>
- 2) Install the intake manifold to the tumble generator valve assembly.

NOTE:

Use a new gasket.

Tightening torque:

8.3 N·m (0.8 kgf·m, 6.1 ft·lb)

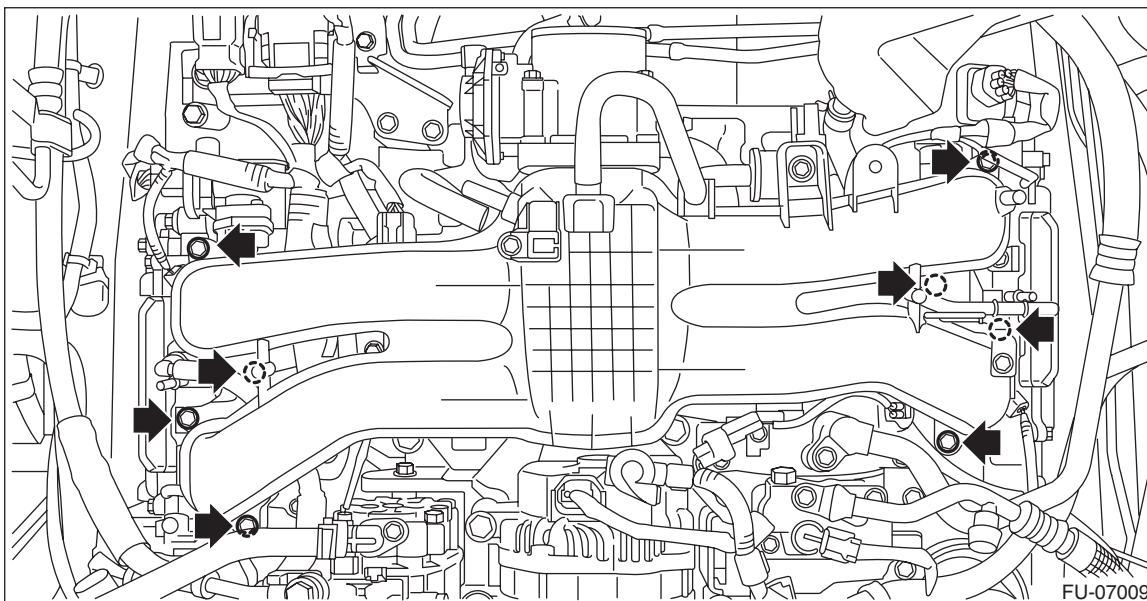

- 3) Connect the fuel delivery hose (A) and evaporation hose (B). <Ref. to FU(H4DO)-169, EVAPORATION HOSE CONNECTION, INSTALLATION, Fuel Delivery and Evaporation Lines.>

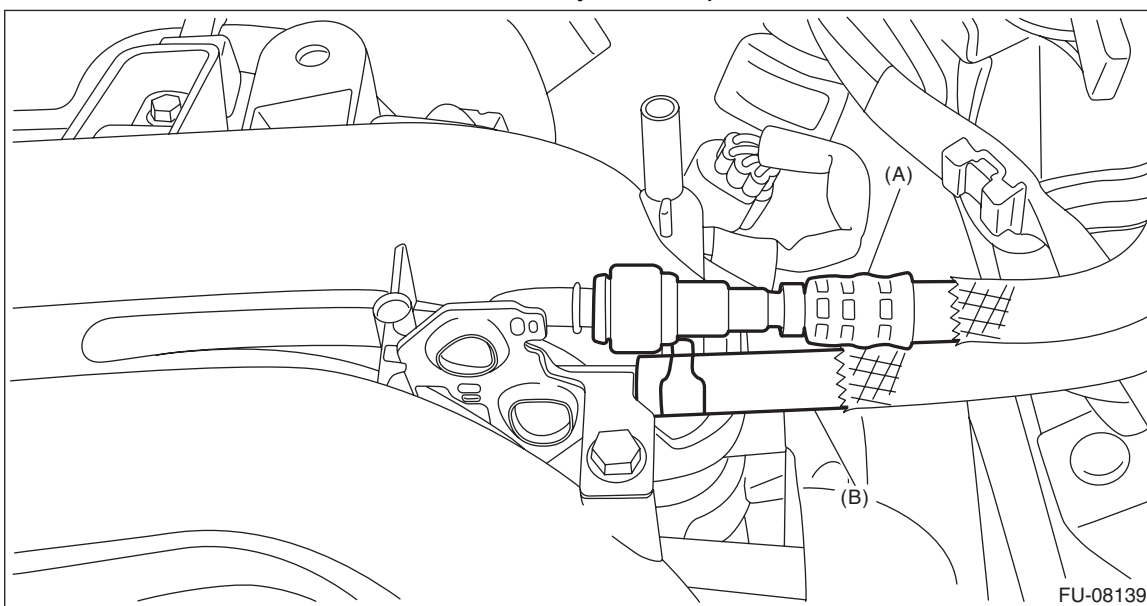

Intake Manifold

FUEL INJECTION (FUEL SYSTEMS)

4) Connect the fuel delivery pipe to the fuel pipe LH.

CAUTION:

- Check that there is no damage or dust on the quick connector. If necessary, clean the seal surface of the pipe.
- When connecting the quick connector, make sure to insert the pipe all the way in before locking the slider.
- When it is difficult to lock the slider, check that the pipe is fully inserted.
- Make sure that the quick connector is securely connected.

NOTE:

Connect the quick connector as shown in the figure.

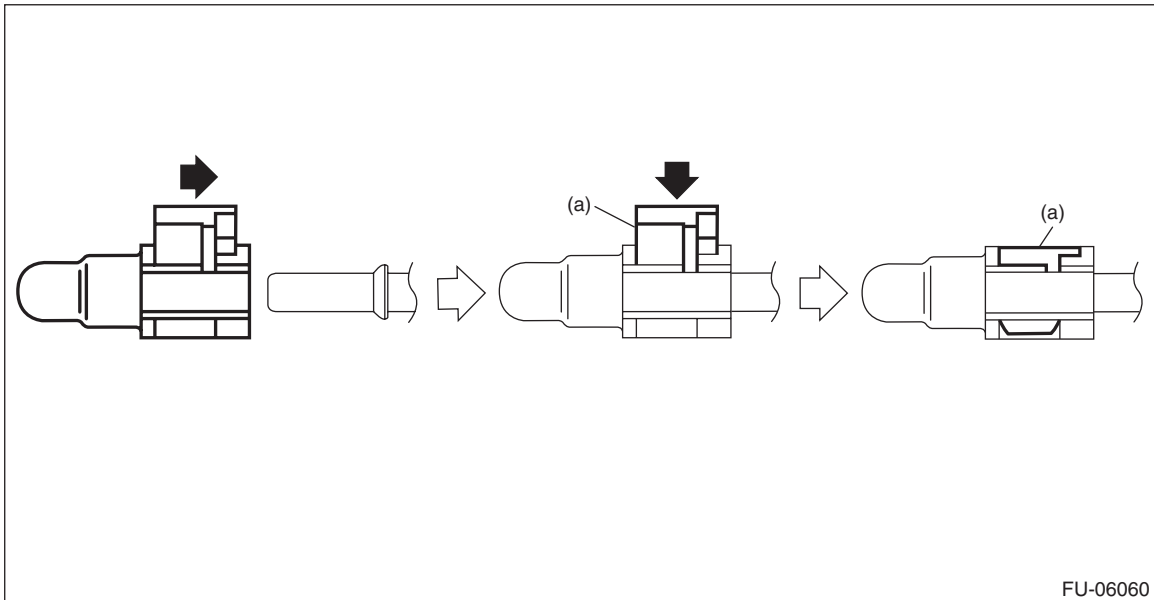

(a) Slider

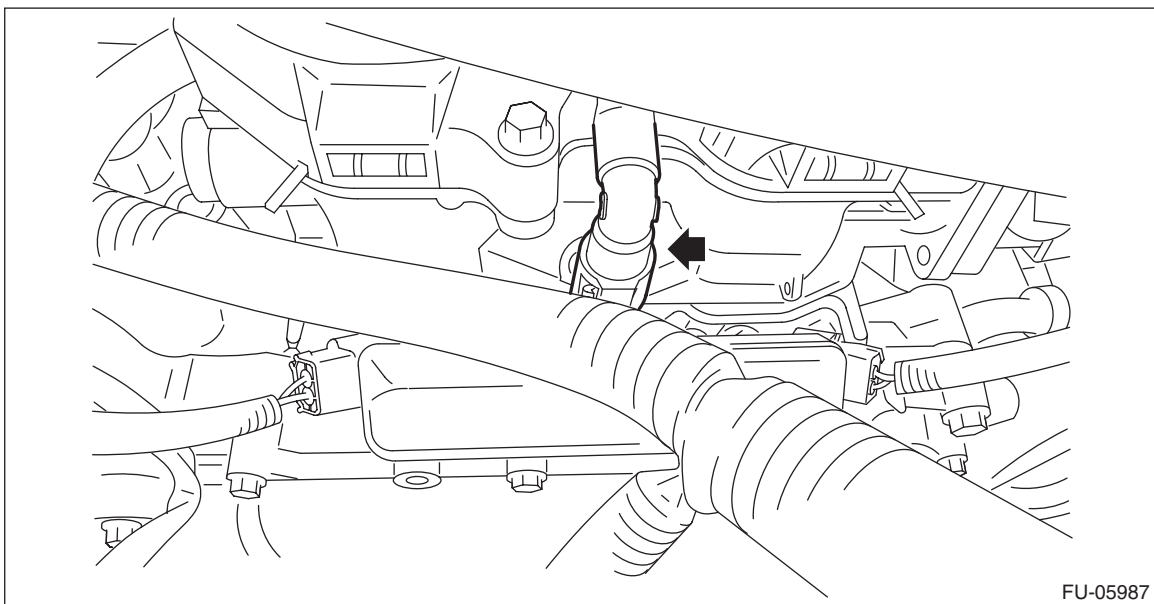

Intake Manifold

FUEL INJECTION (FUEL SYSTEMS)

5) Install the intake manifold protector LH.

Tightening torque:

6.4 N·m (0.7 kgf-m, 4.7 ft-lb)

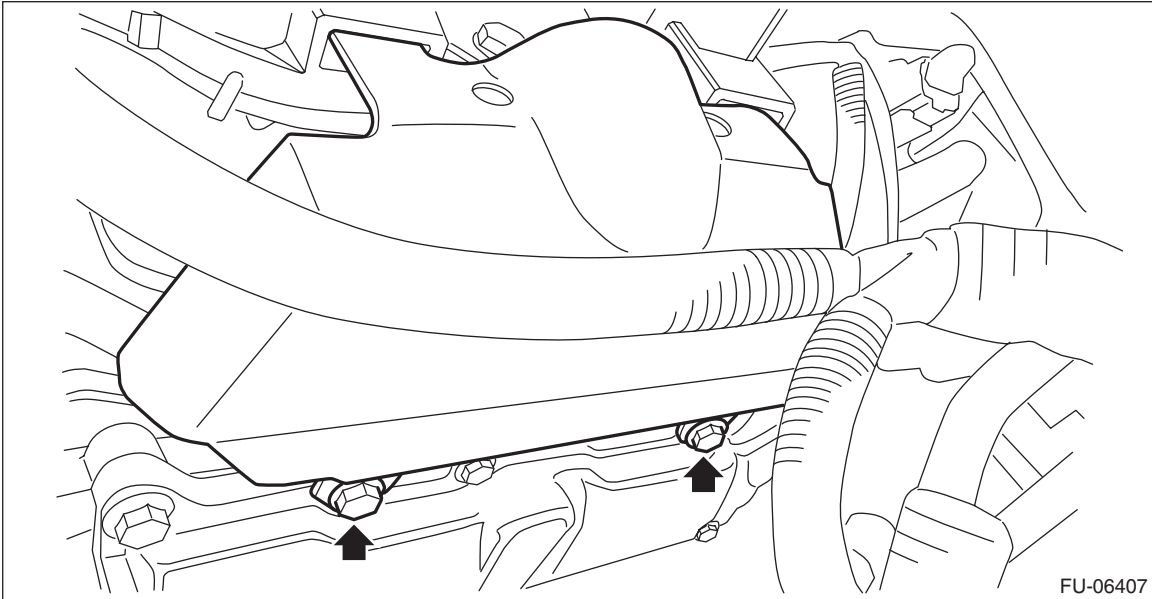

FU-06407

Intake Manifold

FUEL INJECTION (FUEL SYSTEMS)

6) Connect the fuel delivery pipe to the fuel pipe RH.

CAUTION:

- Check that there is no damage or dust on the quick connector. If necessary, clean the seal surface of the pipe.
- When connecting the quick connector, make sure to insert the pipe all the way in before locking the slider.
- When it is difficult to lock the slider, check that the pipe is fully inserted.
- Make sure that the quick connector is securely connected.

NOTE:

Connect the quick connector as shown in the figure.

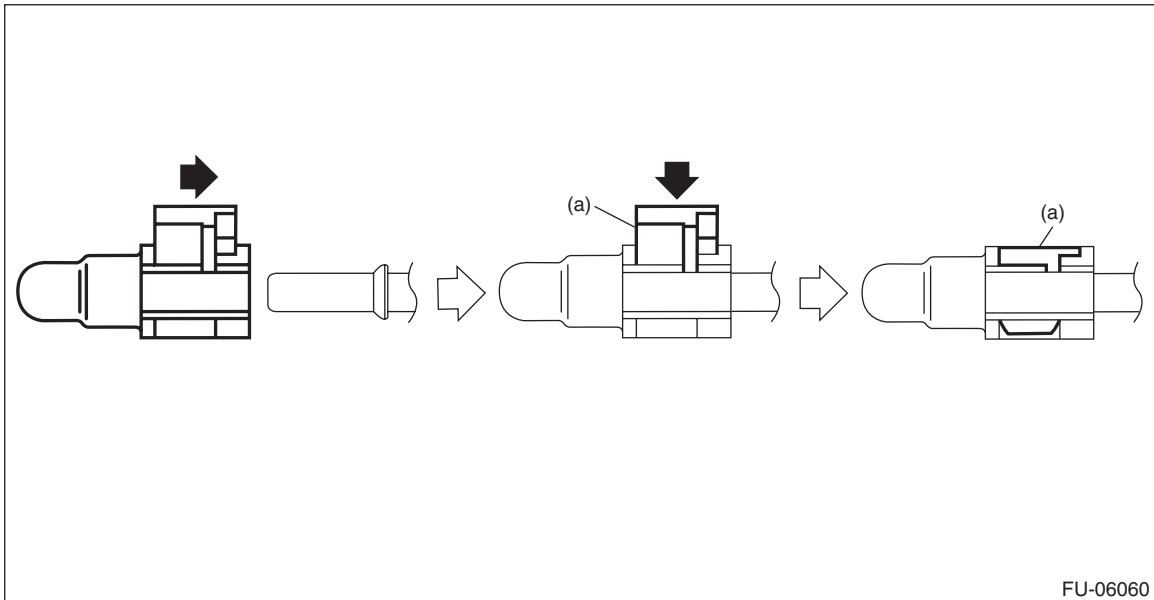

(a) Slider

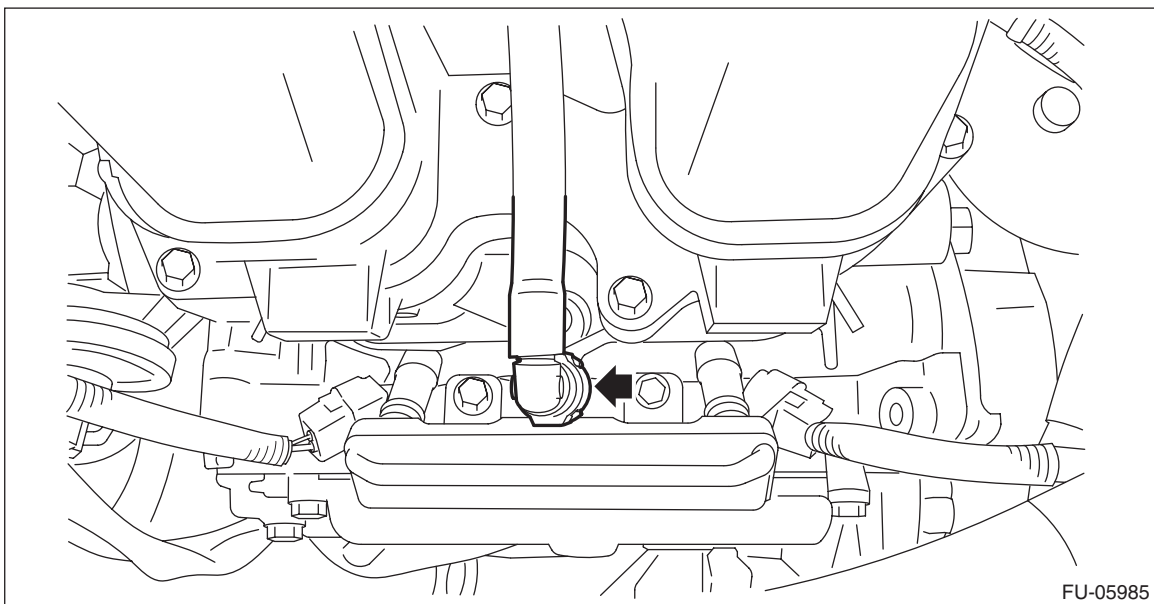

Intake Manifold

FUEL INJECTION (FUEL SYSTEMS)

7) Install the intake manifold protector RH.

Tightening torque:

6.4 N·m (0.7 kgf·m, 4.7 ft·lb)

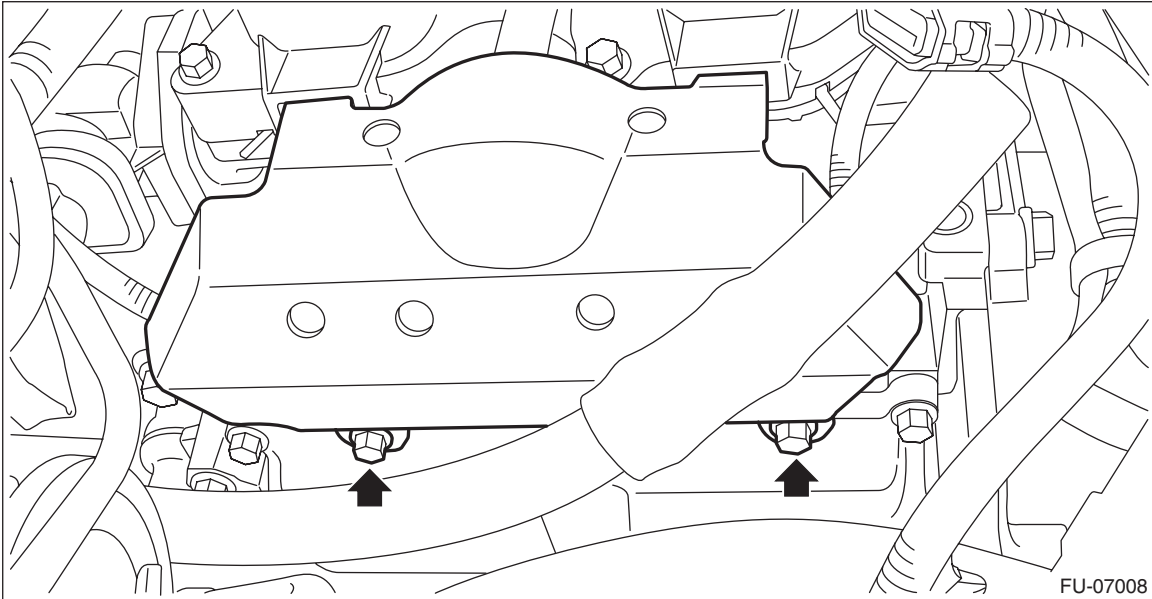

8) Install the air intake case (rear).

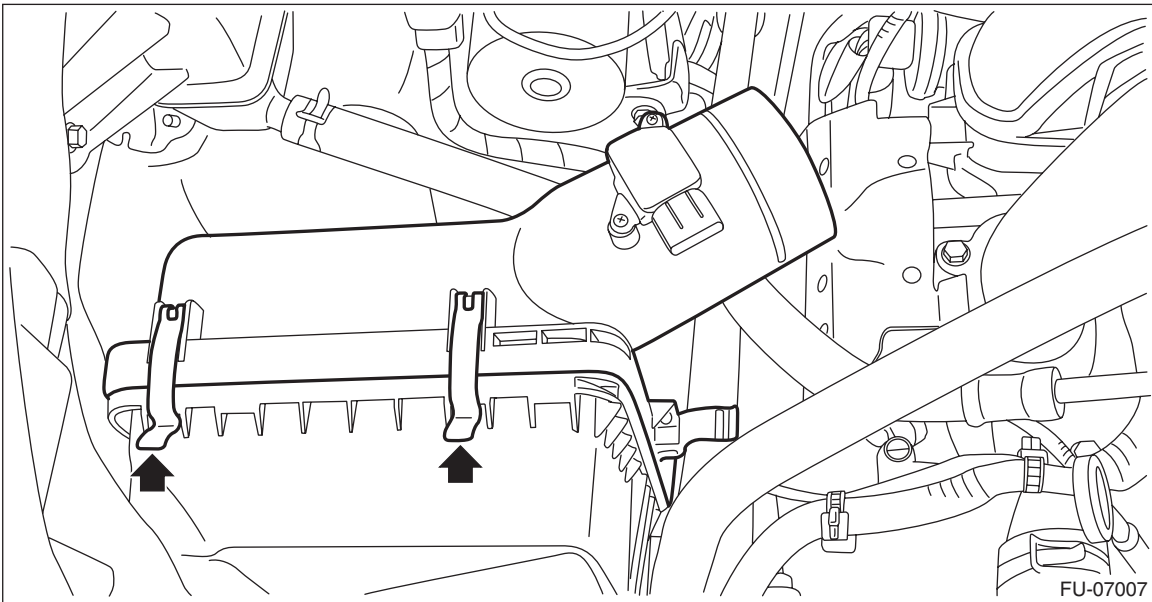

Intake Manifold

FUEL INJECTION (FUEL SYSTEMS)

9) Install the clip (B) which secures the air flow and intake air temperature sensor harness, and connect the connector (A) to the air flow and intake air temperature sensor.

10) Install the suction hose (C) to the air cleaner case (rear).

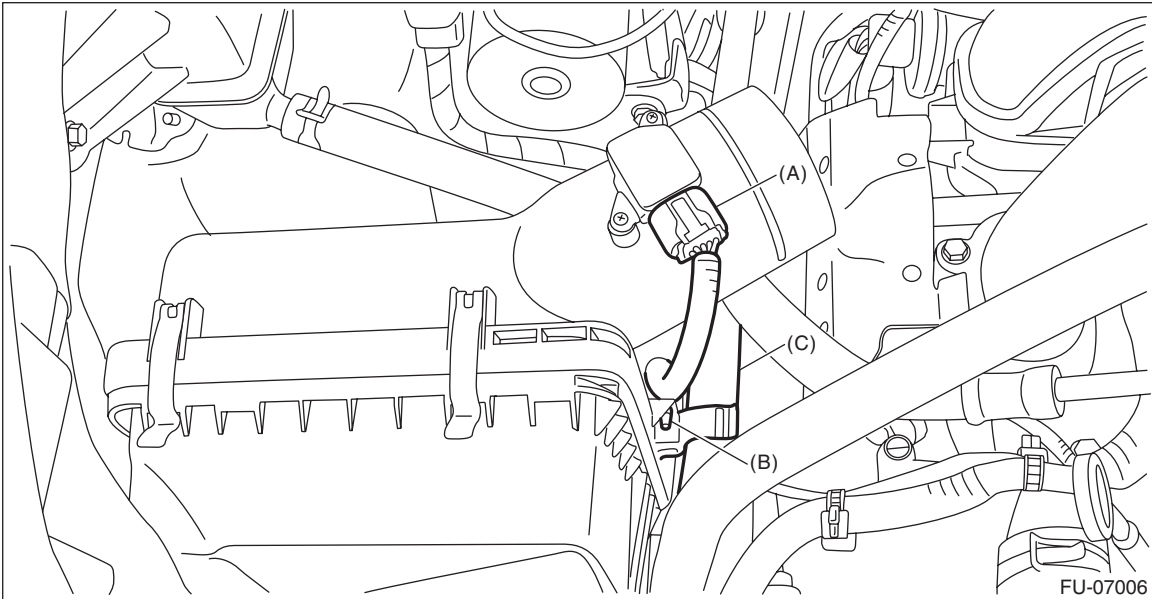

11) Connect the brake booster vacuum hose to the intake manifold.

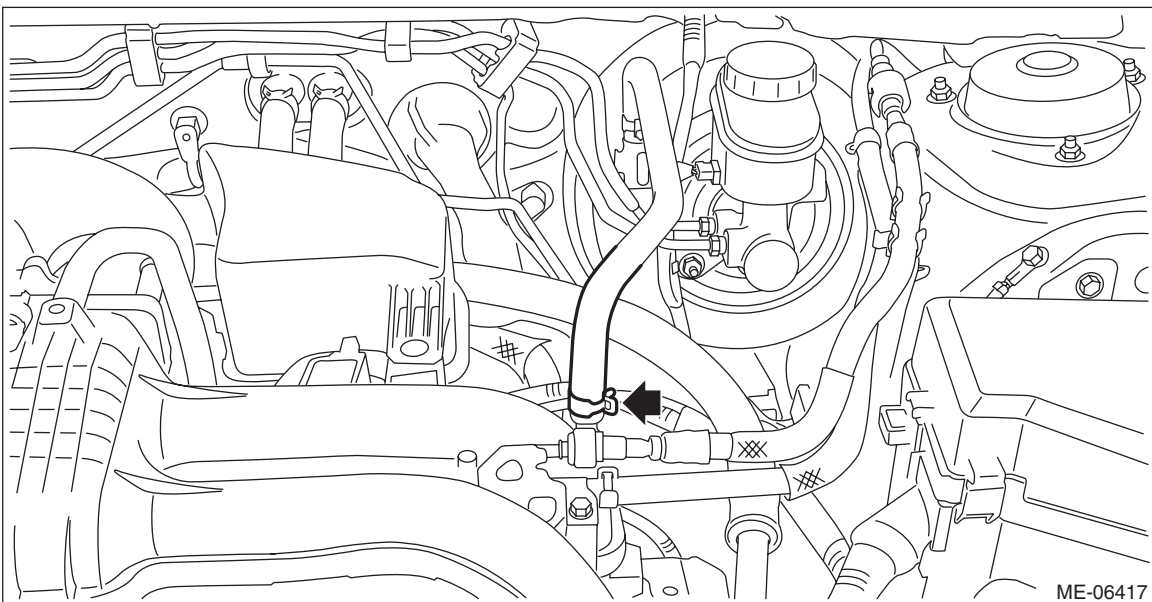

Intake Manifold

FUEL INJECTION (FUEL SYSTEMS)

- 12) Connect the PCV hose (A) to intake manifold.
- 13) Connect the connector (B) to the manifold absolute pressure sensor.
- 14) Connect the connector (C) to the throttle position sensor.

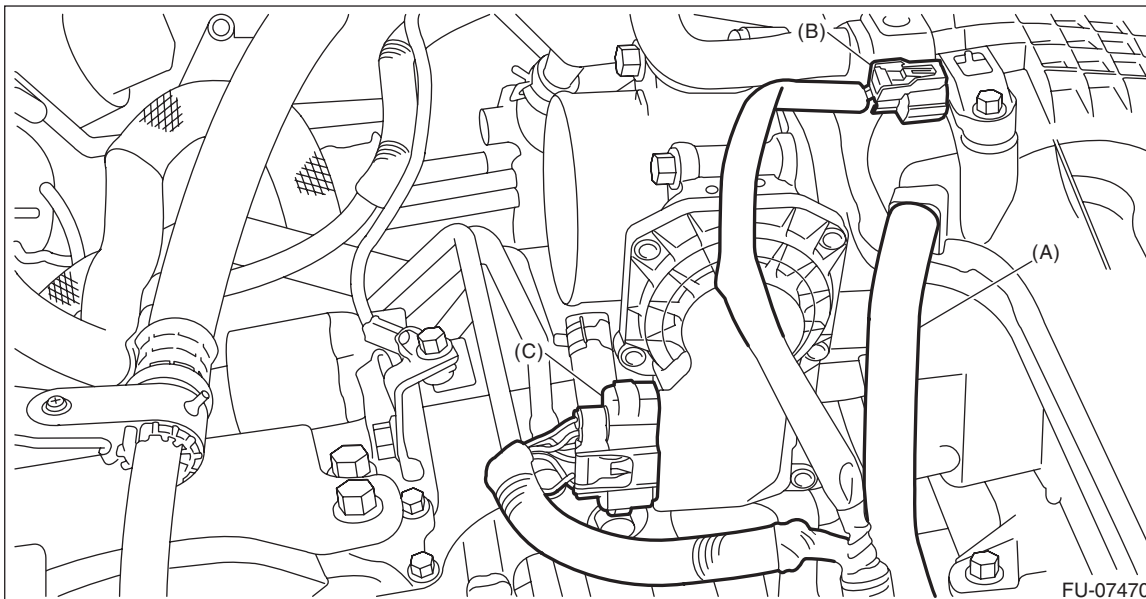

- 15) Connect the connector (A) to the purge control solenoid valve.
- 16) Tighten the nut (C) and bolt (B) which hold EGR pipe to the water pipe assembly.

NOTE:

- Use a new gasket.
- Always tighten the EGR pipe at (C) first, and then (B).

Tightening torque:

6.4 N·m (0.7 kgf·m, 4.7 ft·lb)

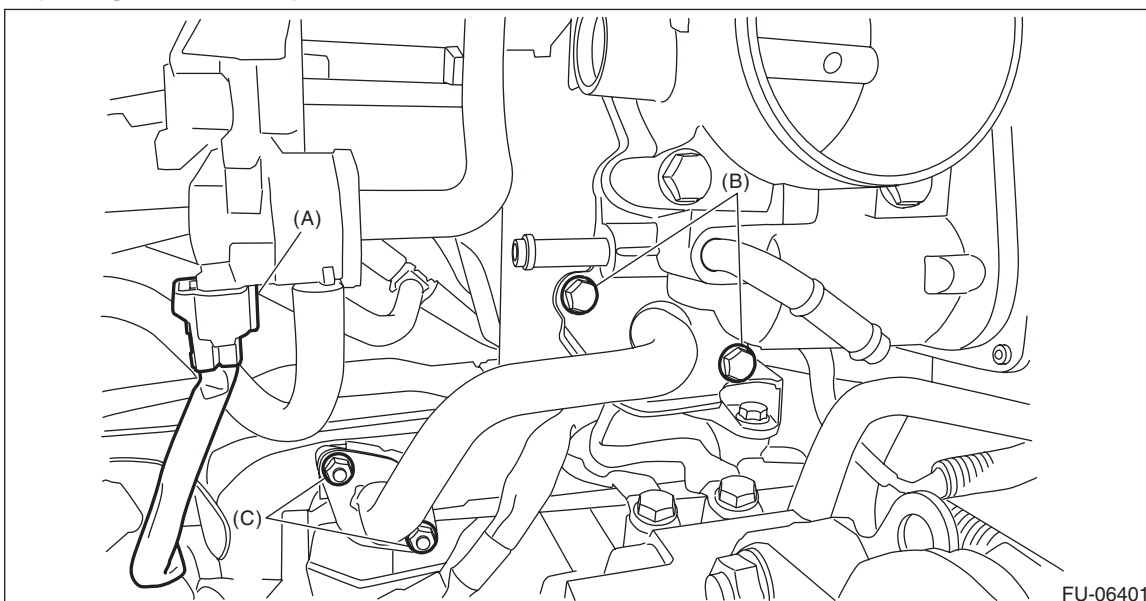

Intake Manifold

FUEL INJECTION (FUEL SYSTEMS)

17) Install the preheater hose to the throttle body.

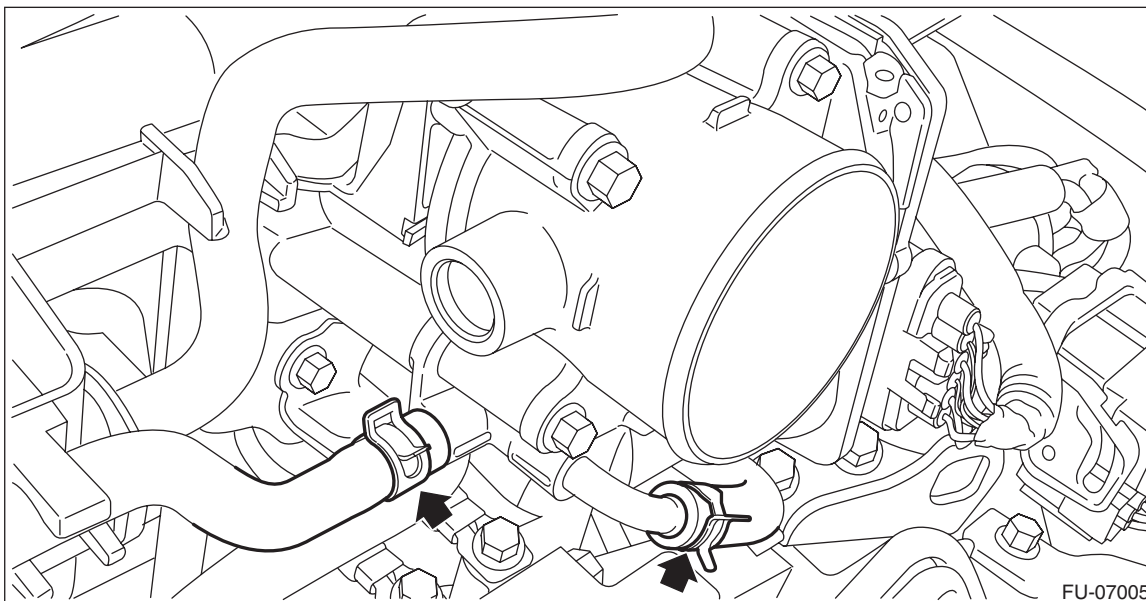

18) Install the air intake boot. <Ref. to IN(H4DO)-13, INSTALLATION, Air Intake Boot.>

19) Lift up the vehicle.

20) Install the under cover. <Ref. to EI-33, INSTALLATION, Front Under Cover.>

21) Lower the vehicle.

22) Connect the battery ground terminal.

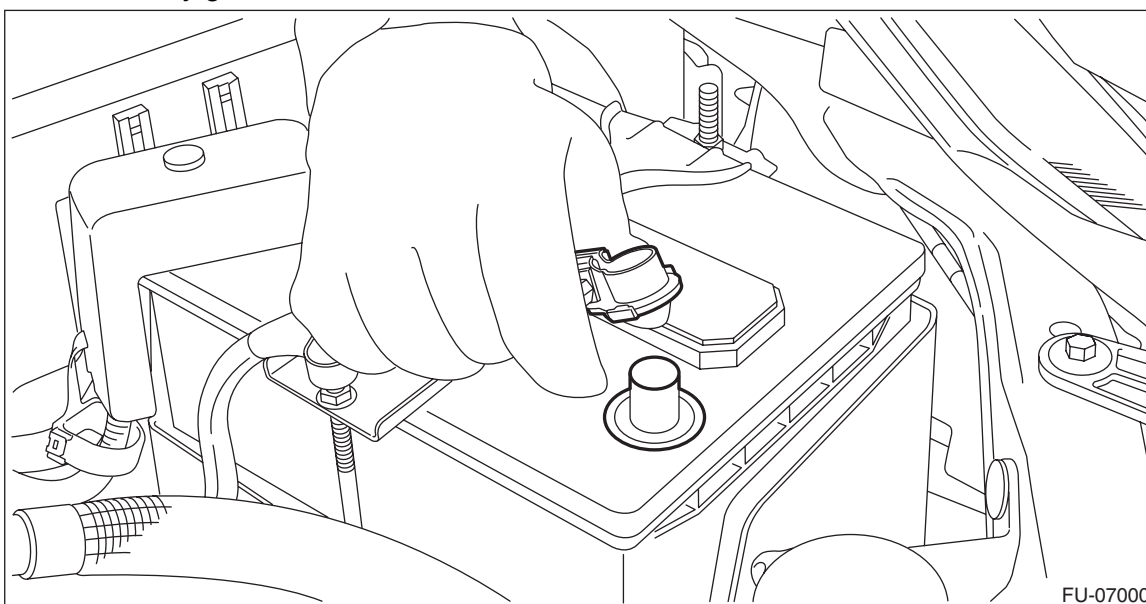

23) Fill engine coolant. <Ref. to CO(H4DO)-15, FILLING OF ENGINE COOLANT, REPLACEMENT, Engine Coolant.>

C: DISASSEMBLY

- 1) Remove the throttle body. <Ref. to FU(H4DO)-15, REMOVAL, Throttle Body.>
- 2) Remove the purge control solenoid valve. <Ref. to EC(H4DO)-18, REMOVAL, Purge Control Solenoid Valve.>
- 3) Remove the manifold absolute pressure sensor. <Ref. to FU(H4DO)-73, REMOVAL, Manifold Absolute Pressure Sensor.>
- 4) Remove the EGR pipe from intake manifold.

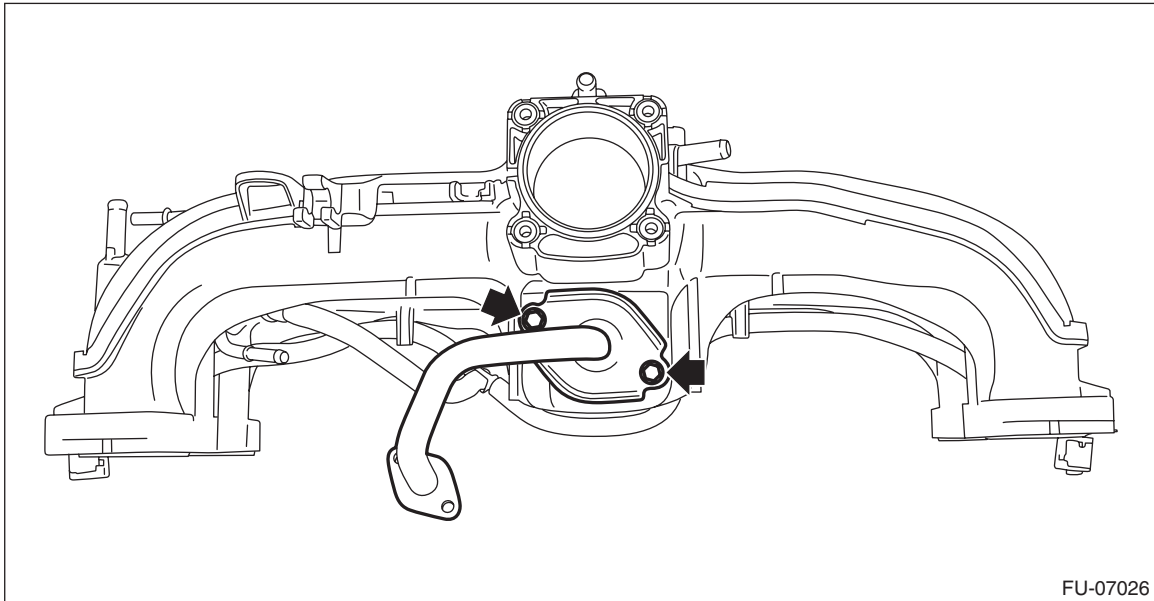

Intake Manifold

FUEL INJECTION (FUEL SYSTEMS)

5) Remove the fuel delivery pipe from intake manifold.

NOTE:

Disconnect the quick connector as shown in the figure.

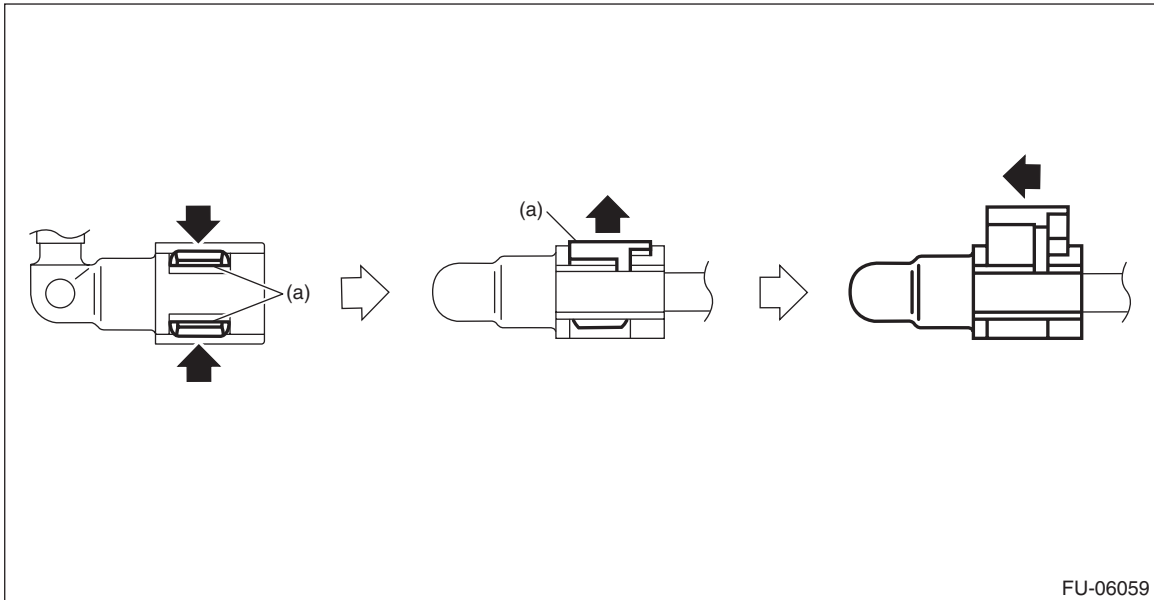

(a) Slider

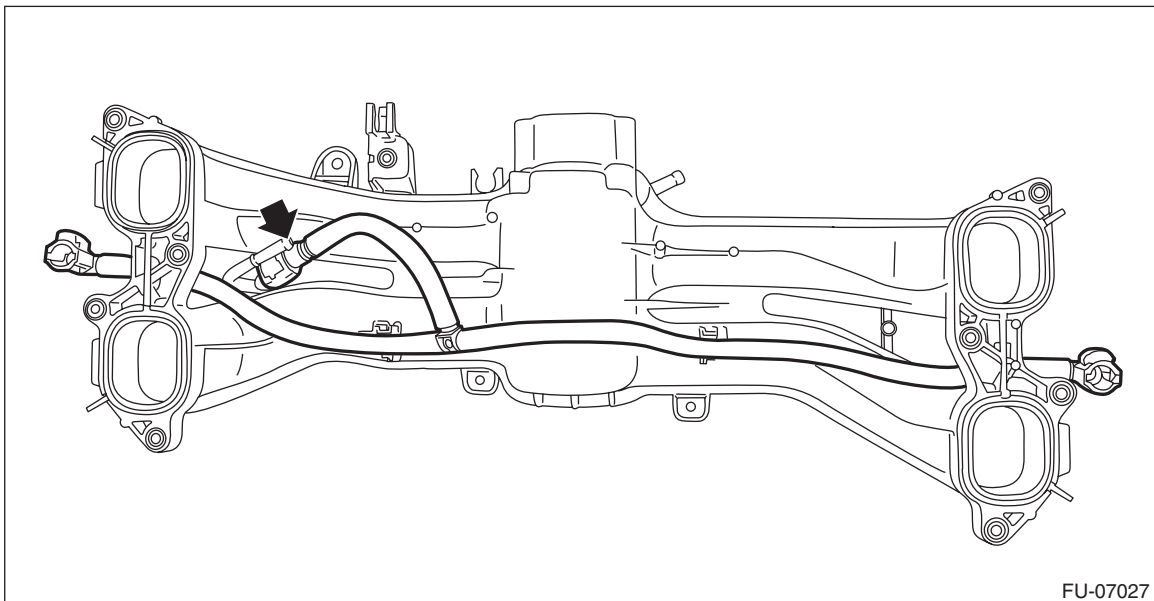

Intake Manifold

FUEL INJECTION (FUEL SYSTEMS)

6) Remove the fuel pipe from intake manifold.

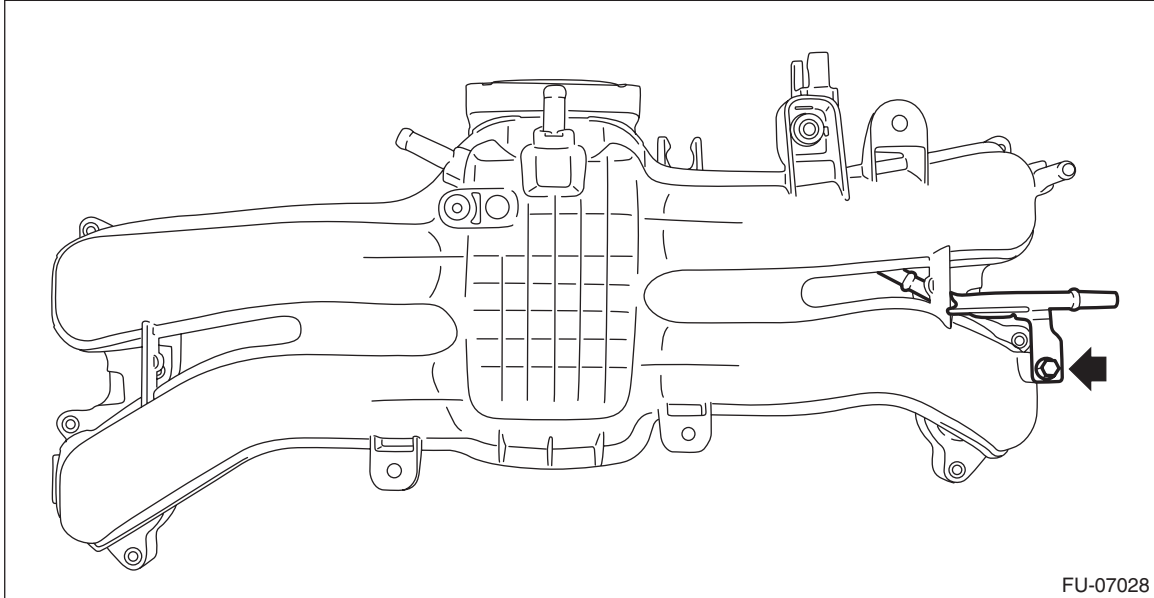

D: ASSEMBLY

1) Install the fuel pipe to the intake manifold.

Tightening torque:

6.4 N·m (0.7 kgf-m, 4.7 ft-lb)

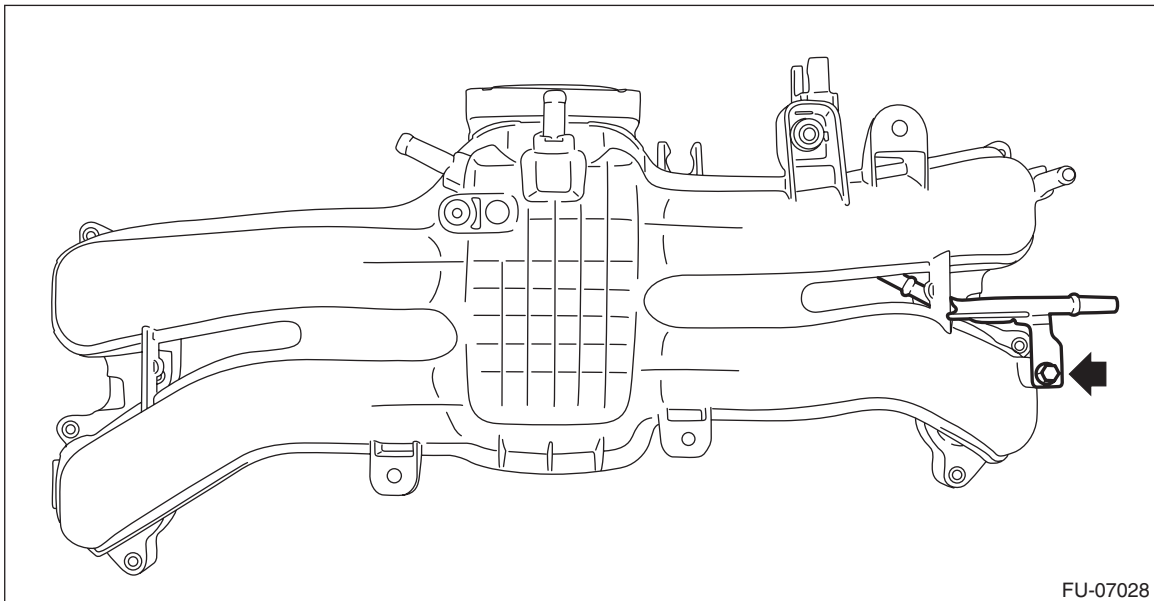

Intake Manifold

FUEL INJECTION (FUEL SYSTEMS)

2) Install the fuel delivery pipe to the intake manifold.

CAUTION:

- Check that there is no damage or dust on the quick connector. If necessary, clean the seal surface of the pipe.
- When connecting the quick connector, make sure to insert the pipe all the way in before locking the slider.
- When it is difficult to lock the slider, check that the pipe is fully inserted.
- Make sure that the quick connector is securely connected.

NOTE:

Connect the quick connector as shown in the figure.

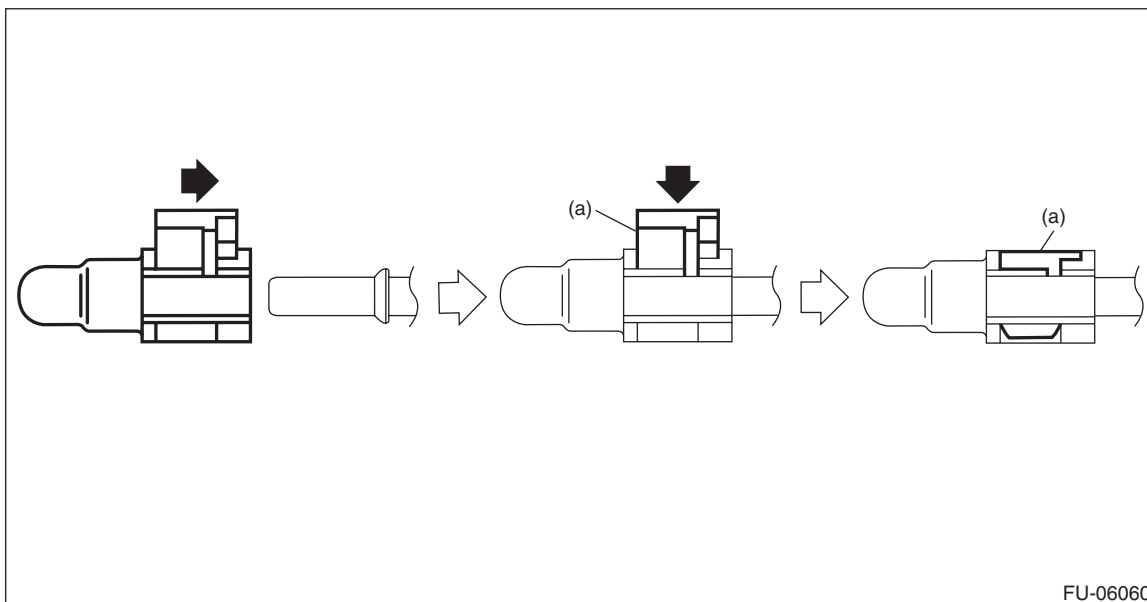

(a) Slider

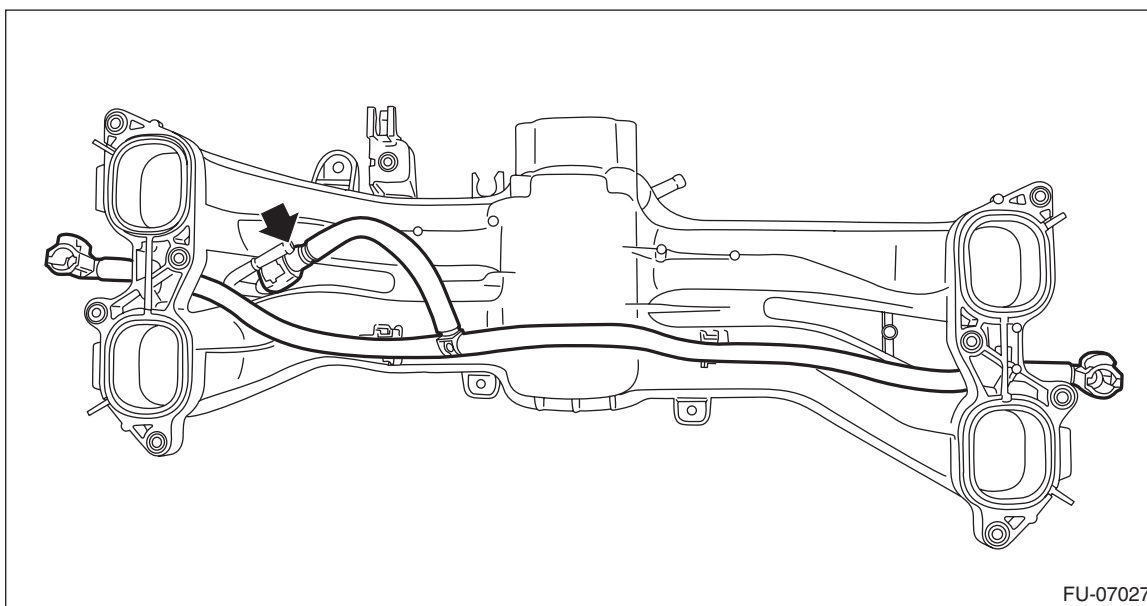

3) Temporarily install the EGR pipe to the intake manifold.

NOTE:

- Use a new gasket.
- Tighten the EGR pipe when installing the intake manifold.

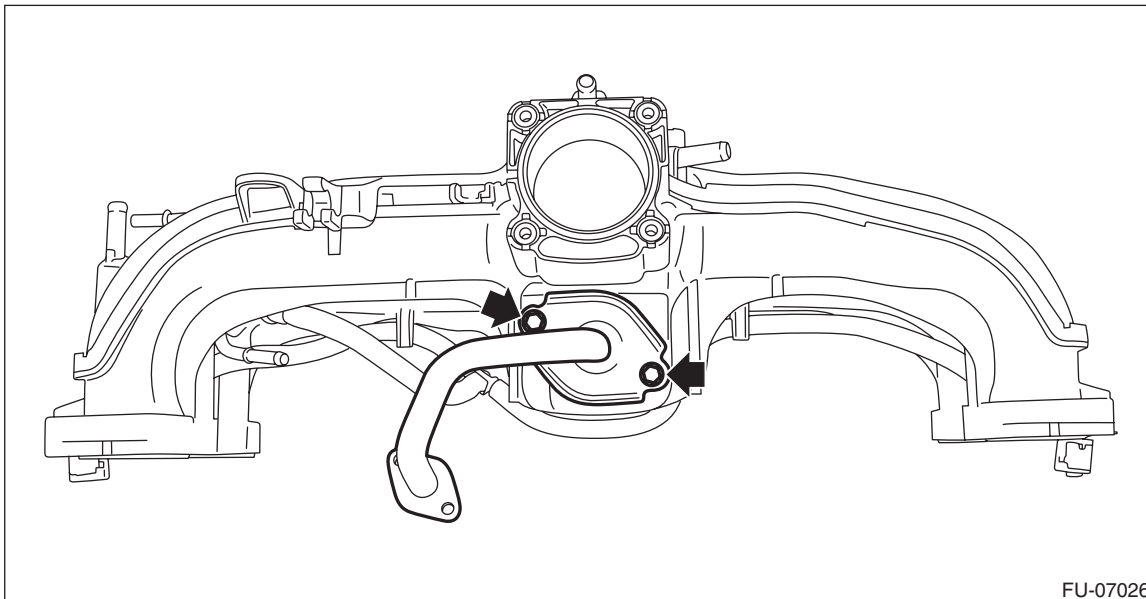

4) Install the manifold absolute pressure sensor. <Ref. to FU(H4DO)-73, INSTALLATION, Manifold Absolute Pressure Sensor.>

5) Install the purge control solenoid valve. <Ref. to EC(H4DO)-20, INSTALLATION, Purge Control Solenoid Valve.>

6) Install the throttle body. <Ref. to FU(H4DO)-17, INSTALLATION, Throttle Body.>

E: INSPECTION

- 1) Check that the intake manifold and fuel pipe have no deformation, cracks and other damages.
- 2) Check that the hose has no cracks, damage or loose part.