

30. Fuel Sub Level Sensor

A: REMOVAL

WARNING:

Place “NO OPEN FLAMES” signs near the working area.

CAUTION:

- Be careful not to spill fuel.
- Catch the fuel from the tubes using a container or cloth.
- If the fuel gauge indicates that two thirds or more of the fuel is remaining, be sure to drain fuel before starting work to avoid the fuel to spill.

1) Release the fuel pressure. <Ref. to FU(H4DO)-109, RELEASING OF FUEL PRESSURE, PROCEDURE, Fuel.>

2) Drain fuel. <Ref. to FU(H4DO)-109, DRAINING FUEL (WITH SUBARU SELECT MONITOR), PROCEDURE, Fuel.>

3) Disconnect the ground cable from battery.

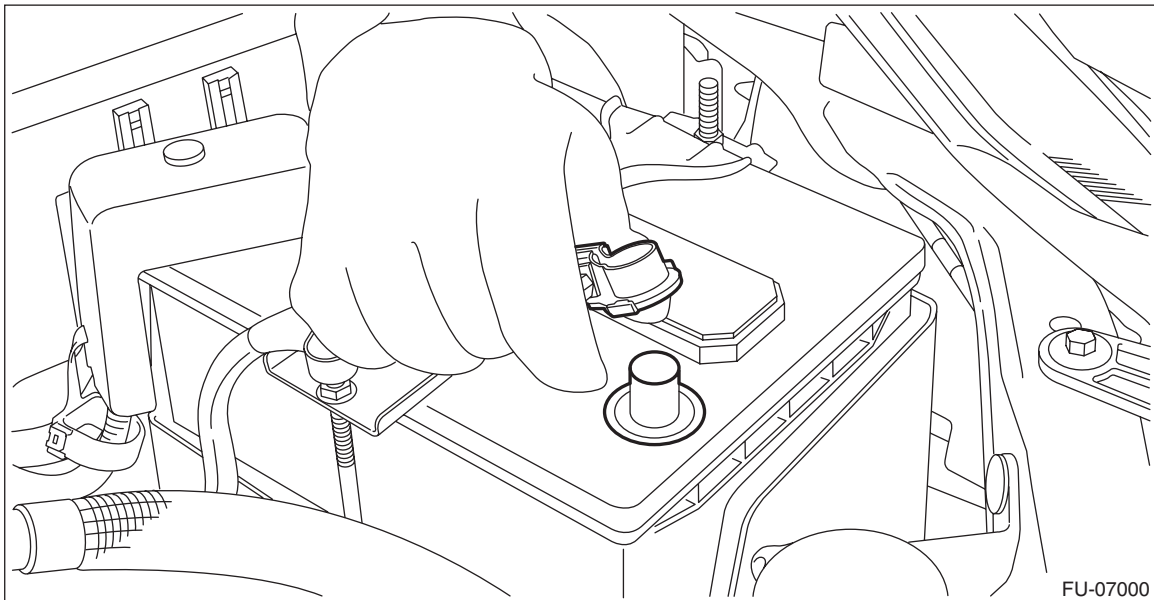

4) Remove the rear seat cushion. <Ref. to SE-34, REMOVAL, Rear Seat.>

5) Remove the service hole cover.

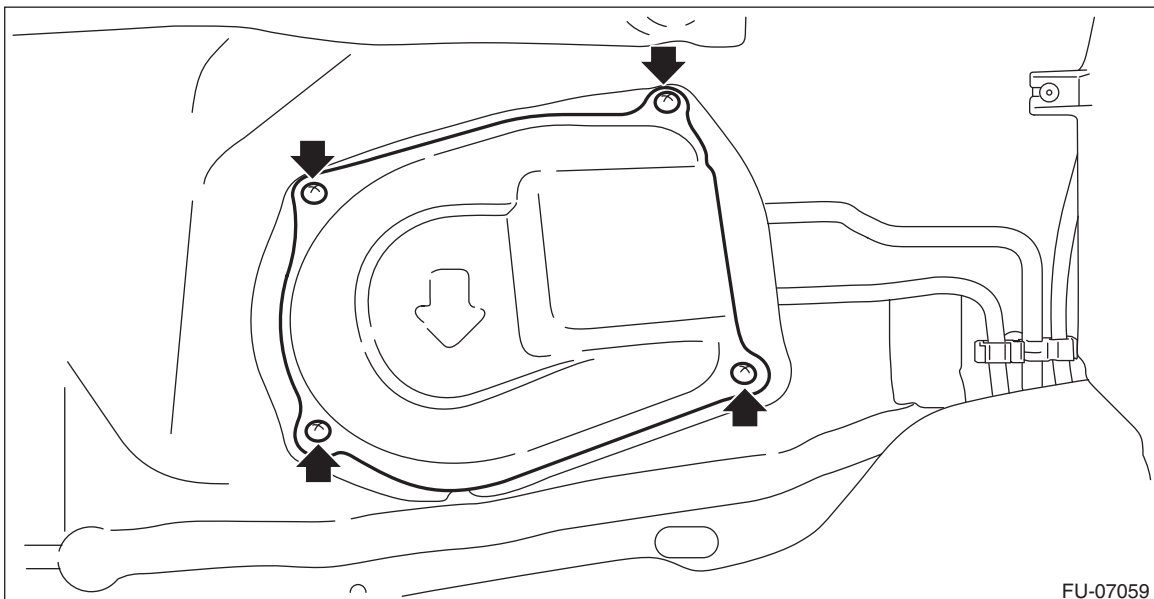

Fuel Sub Level Sensor

FUEL INJECTION (FUEL SYSTEMS)

6) Disconnect the connector (A) from fuel sub level sensor, and remove the clip (B) securing the fuel cord from fuel sub level sensor protector.

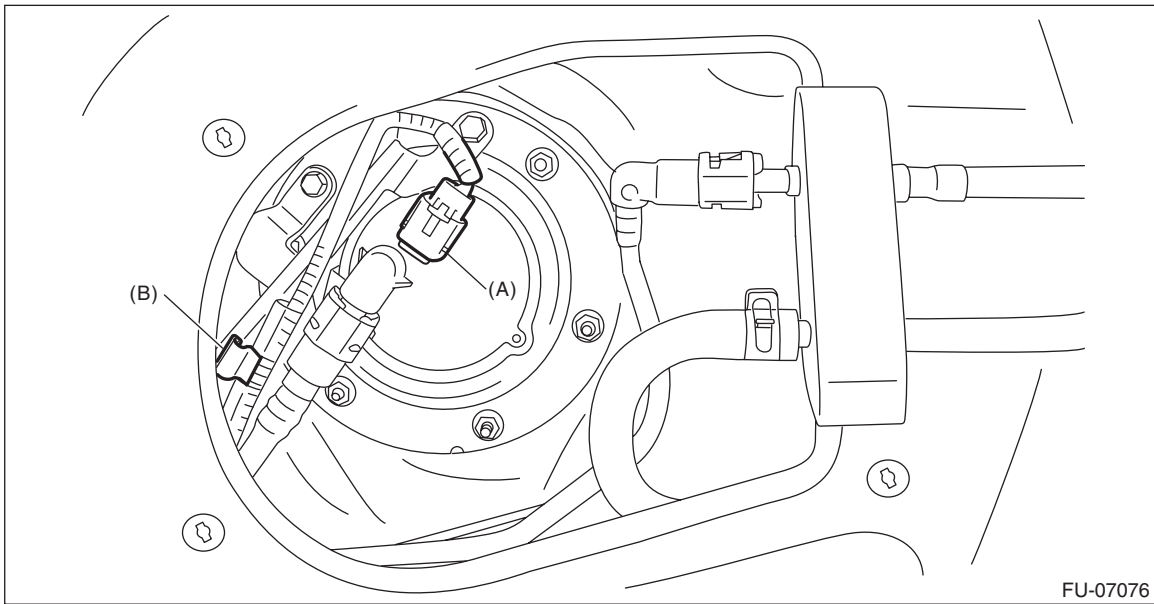

7) Remove the bolts (A) securing the fuel sub level sensor protector to the fuel sub level sensor upper plate, and remove the fuel sub level sensor protector.

8) Disconnect the quick connector on the fuel sub delivery tube (B). <Ref. to FU(H4DO)-158, REMOVAL, Fuel Delivery and Evaporation Lines.>

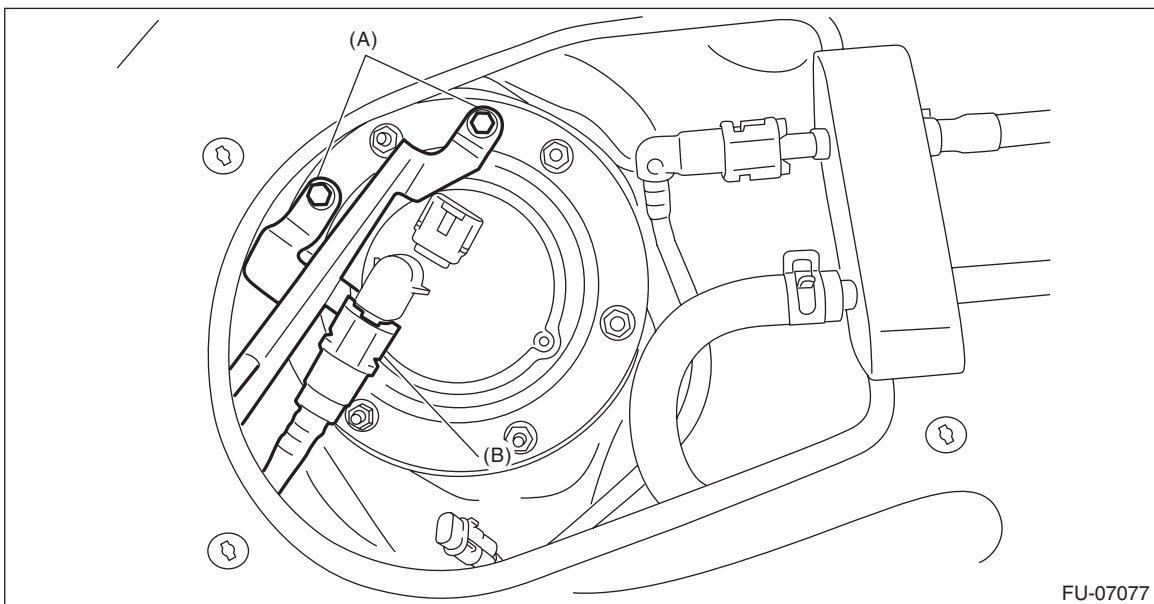

Fuel Sub Level Sensor

FUEL INJECTION (FUEL SYSTEMS)

9) Remove the nuts securing the fuel sub level sensor upper plate to the fuel tank and remove the fuel sub level sensor upper plate.

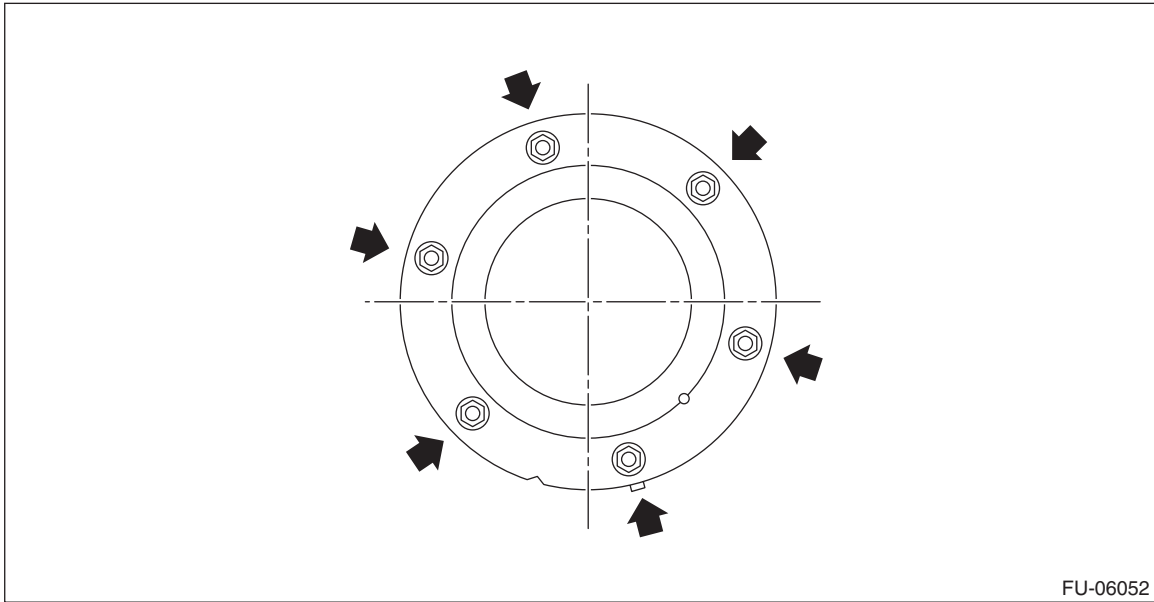

10) Remove the fuel sub level sensor from the fuel tank.

Fuel Sub Level Sensor

FUEL INJECTION (FUEL SYSTEMS)

B: INSTALLATION

Install in the reverse order of removal while being careful of the following.

- Make sure the sealing portion is free from fuel or foreign matter before installation.
- Align protrusion (A) of the gasket to the position shown in the figure.
- Align protrusion (B) of the fuel sub level sensor to the cutout in the fuel sub level sensor upper plate.
- After tightening the bolts to the specified torque in the order indicated in the figure, install the fuel sub level sensor protector.

NOTE:

Use a new gasket.

Tightening torque:

4.4 N·m (0.4 kgf·m, 3.2 ft·lb)

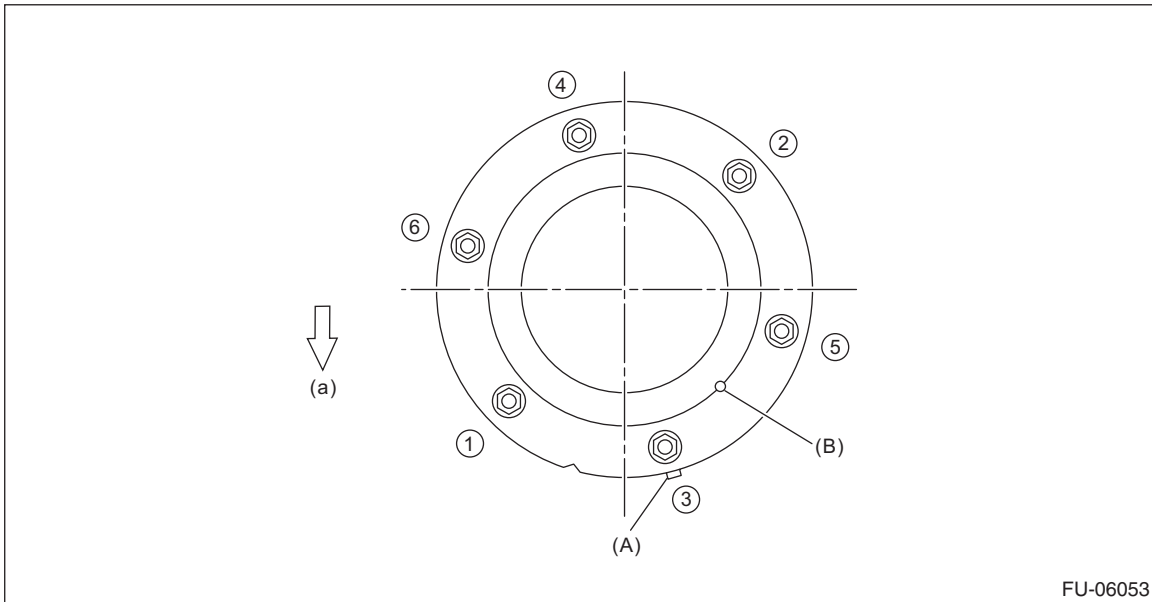

(a) Front side of vehicle

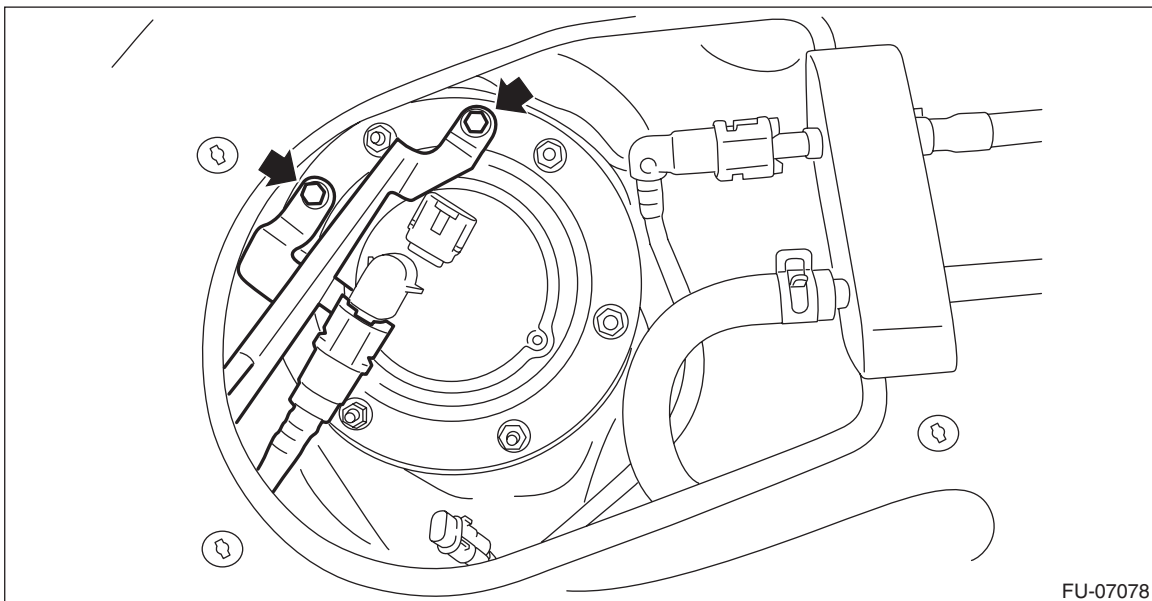

Fuel Sub Level Sensor

C: INSPECTION

- 1) Check that the fuel sub level sensor has no damage.
- 2) Measure the fuel sub level sensor float position.

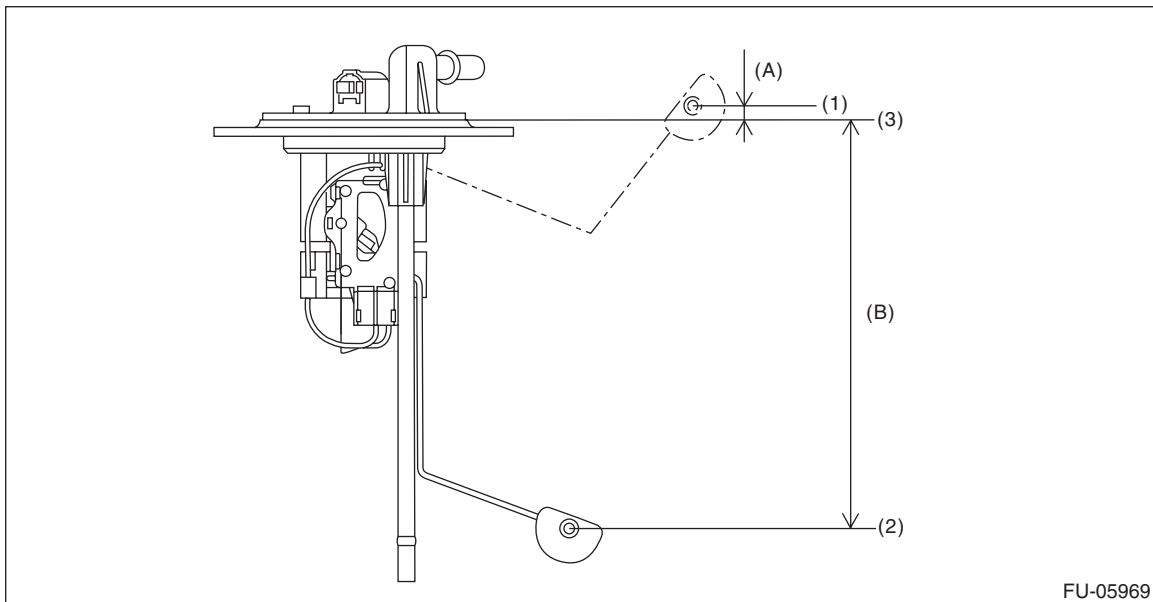

FU-05969

- (1) FULL (2) EMPTY (3) Datum points

Float position	Standard
FULL to Datum point (A)	6.4±3.5 mm (0.252±0.138 in)
EMPTY to Datum point (B)	163.3±3.5 mm (6.429±0.138 in)

- 3) Measure the resistance between fuel sub level sensor terminals.

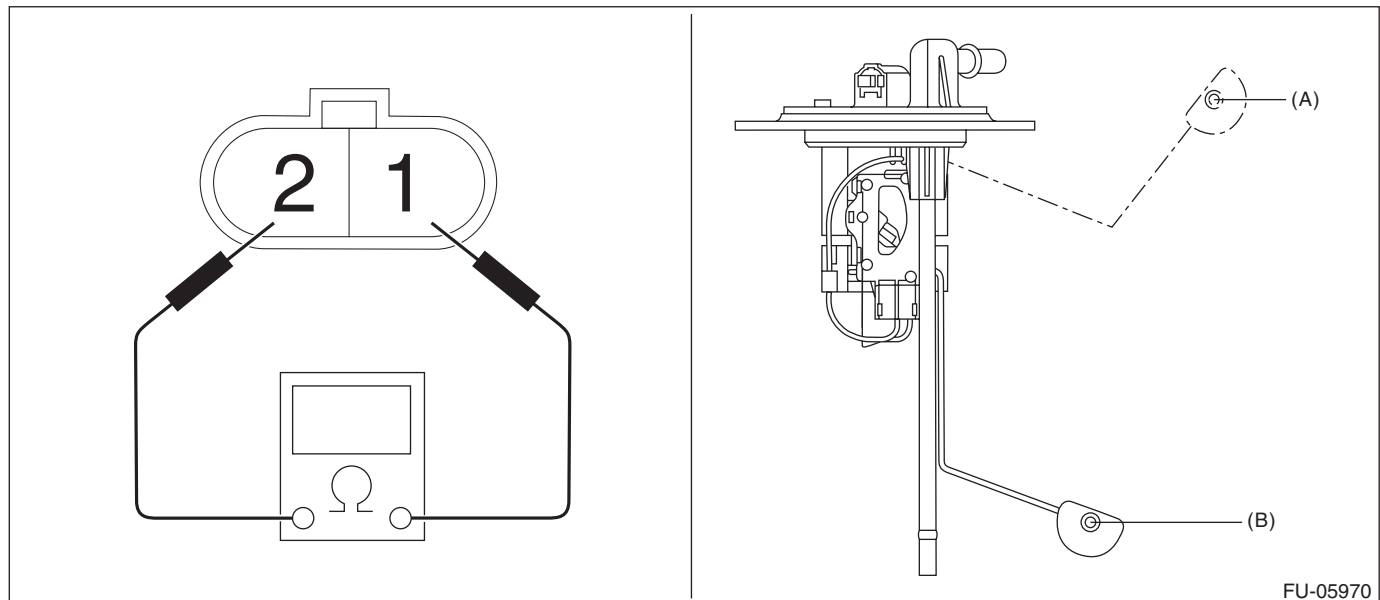

FU-05970

Float position	Terminal No.	Standard
FULL (A)	1 and 2	8.7±1.0 Ω
EMPTY (B)		270.9±4.0 Ω