

5. Engine Coolant Temperature Sensor

A: REMOVAL

1) Disconnect the ground cable from battery.

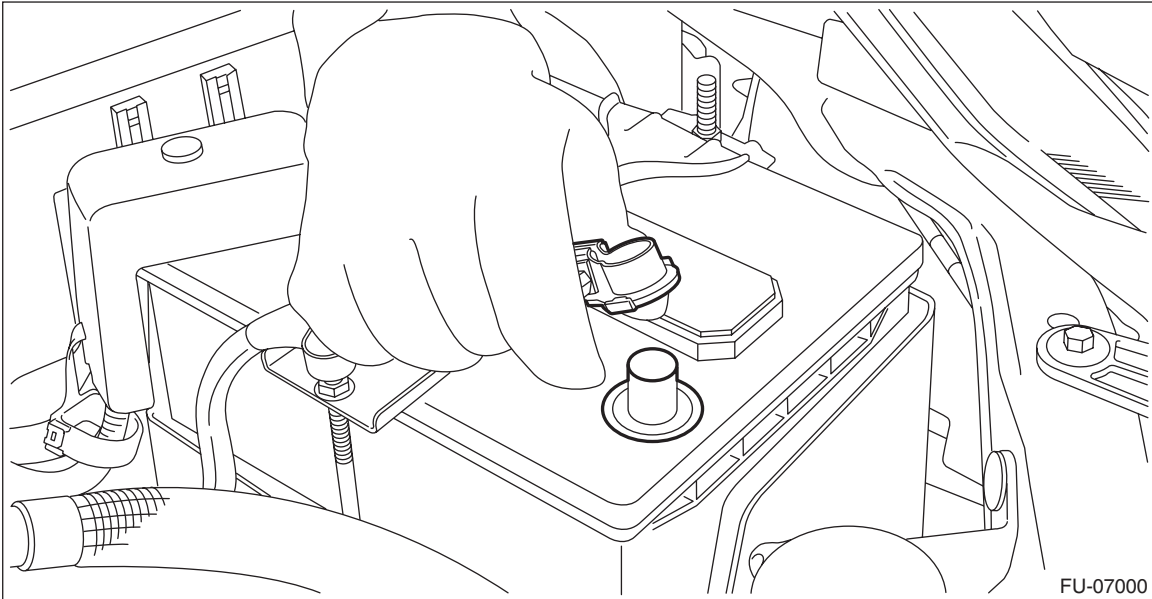

2) Drain engine coolant. <Ref. to CO(H4DO)-14, DRAINING OF ENGINE COOLANT, REPLACEMENT, Engine Coolant.>

3) Disconnect the connector (A) from the engine coolant temperature sensor, and remove the engine coolant temperature sensor.

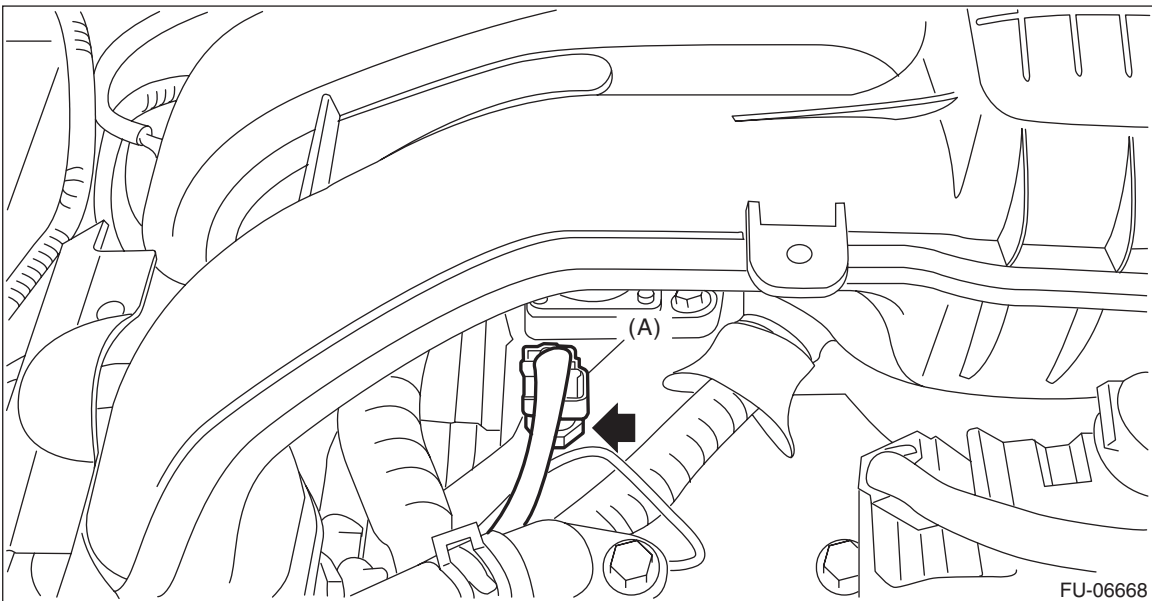

B: INSTALLATION

Install in the reverse order of removal.

NOTE:

Use a new gasket.

Tightening torque:

18 N·m (1.8 kgf·m, 13.3 ft·lb)

Engine Coolant Temperature Sensor

FUEL INJECTION (FUEL SYSTEMS)

C: INSPECTION

- 1) Check that the engine coolant temperature sensor has no deformation, cracks or other damages.
- 2) Immerse the engine coolant temperature sensor and a thermometer in water.

CAUTION:

Take care not to allow water to get into the engine coolant temperature sensor connector. Completely remove any water inside.

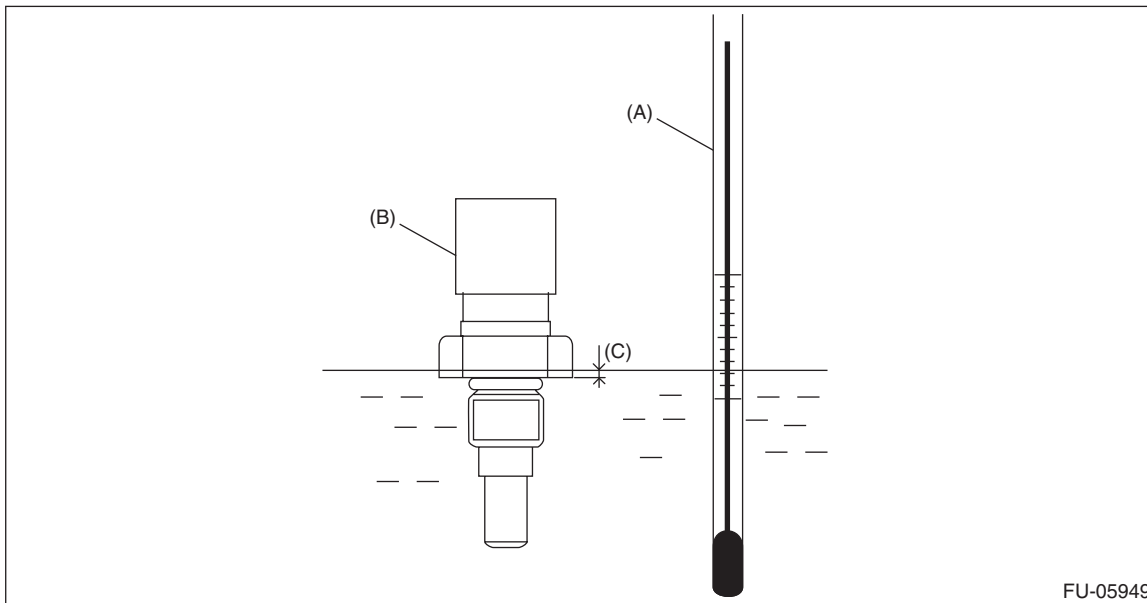

(A) Thermometer

(B) Engine coolant temperature sensor

(C) Hexagonal part height: To approx. $\frac{1}{3}$

- 3) Raise water temperature gradually, measure the resistance between the engine coolant temperature sensor terminals when the temperature is 20°C (68°F) and 80°C (176°F).

NOTE:

Agitate the water for even temperature distribution.

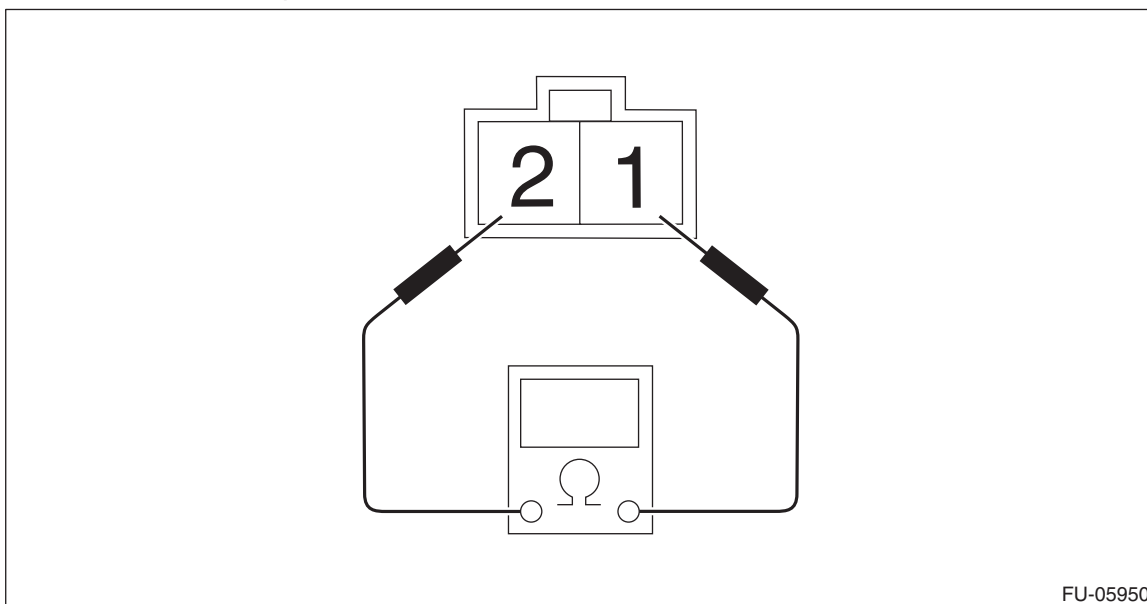

FU-05950

Water temperature	Terminal No.	Standard
20°C (68°F)	1 and 2	Approx. 2.45±0.2 kΩ
80°C (176°F)		Approx. 0.318±0.013 kΩ