

General Description

IGNITION

1. General Description

A: SPECIFICATION

Item		Specifications
Ignition coil	Type	FK0453
	Ignition system	Independent ignition coil
	Manufacturer	Diamond Electric
Spark plug	Manufacturer and type	NGK: SILZKAR7B11
	Thread size (diameter, pitch, length)	mm 12, 1.25, 26.5
	Spark plug gap	mm (in) Standard 1.0 — 1.1 (0.039 — 0.043)
	Electrode	Iridium

B: COMPONENT

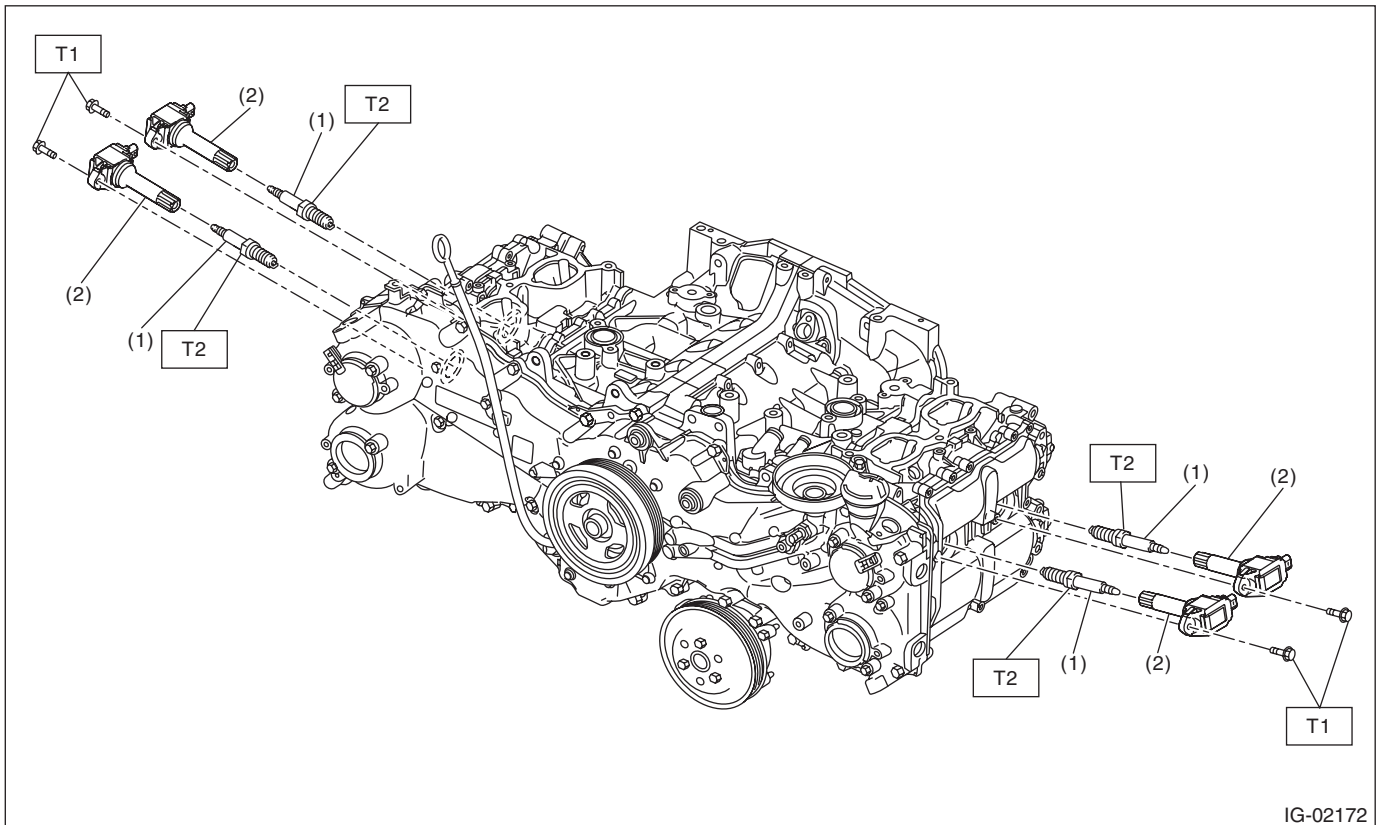

(1) Spark plug

(2) Ignition coil

Tightening torque: N·m (kgf·m, ft·lb)

T1: 8.5 (0.9, 6.3)

T2: 17.5 (1.8, 12.9)

C: CAUTION

- Prior to starting work, pay special attention to the following:
 1. Always wear work clothes, a work cap, and protective shoes. Additionally, wear a helmet, protective goggles, etc. if necessary.
 2. Protect the vehicle using a seat cover, fender cover, etc.
 3. Prepare the service tools, clean cloth, containers to catch grease and oil, etc.
- Vehicle components are extremely hot immediately after driving. Be wary of receiving burns from heated parts.
- When performing a repair, identify the cause of trouble and avoid unnecessary removal, disassembly and replacement.
- Before disconnecting connectors of sensors or units, be sure to disconnect the ground cable from battery.
- Always use the jack-up point when the shop jacks or rigid racks are used to support the vehicle.
- Remove contamination including dirt and corrosion before removal, installation, disassembly or assembly.
- Keep the removed parts in order and protect them from dust and dirt.
- All removed parts, if to be reused, should be reinstalled in the original positions with attention to the correct directions, etc.
- Bolts, nuts and washers should be replaced with new parts as required.
- Be sure to tighten the fasteners including bolts and nuts to the specified torque.