

# Oil Pan and Strainer

LUBRICATION

## 5. Oil Pan and Strainer

### A: REMOVAL

#### 1. OIL PAN

1) Disconnect the ground cable from battery.

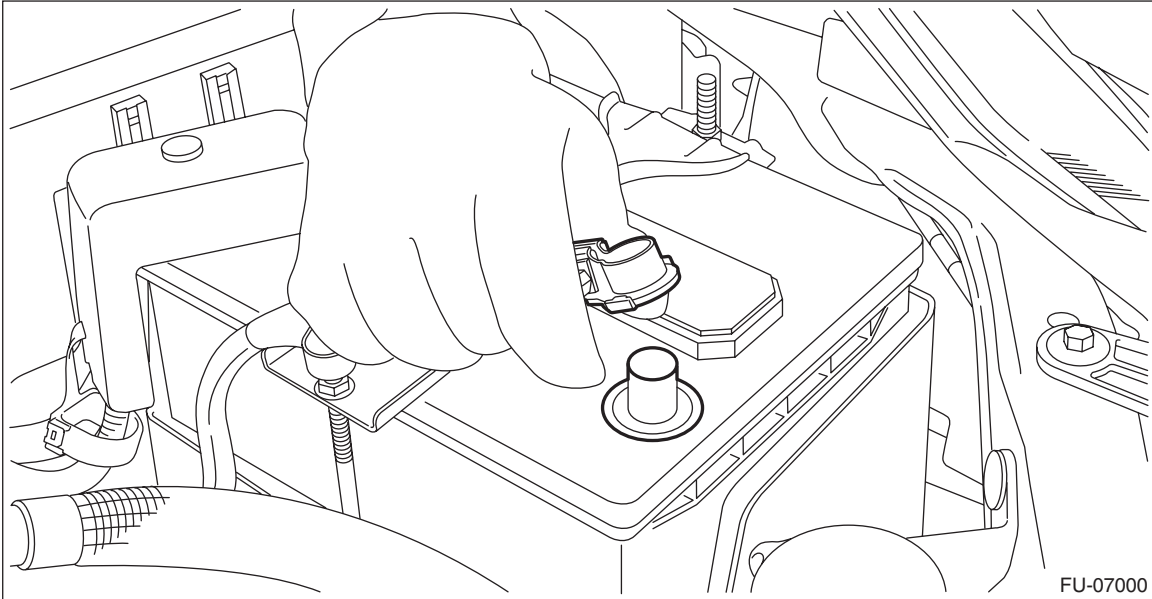

2) Lift up the vehicle.

3) Remove the under cover. <Ref. to EI-33, REMOVAL, Front Under Cover.>

4) Drain the engine oil. <Ref. to LU(H4DO)-9, REPLACEMENT, Engine Oil.>

5) Remove the front exhaust pipe. <Ref. to EX(H4DO)-5, REMOVAL, Front Exhaust Pipe.>

6) Remove the bolts which secure oil pan to oil pan upper.

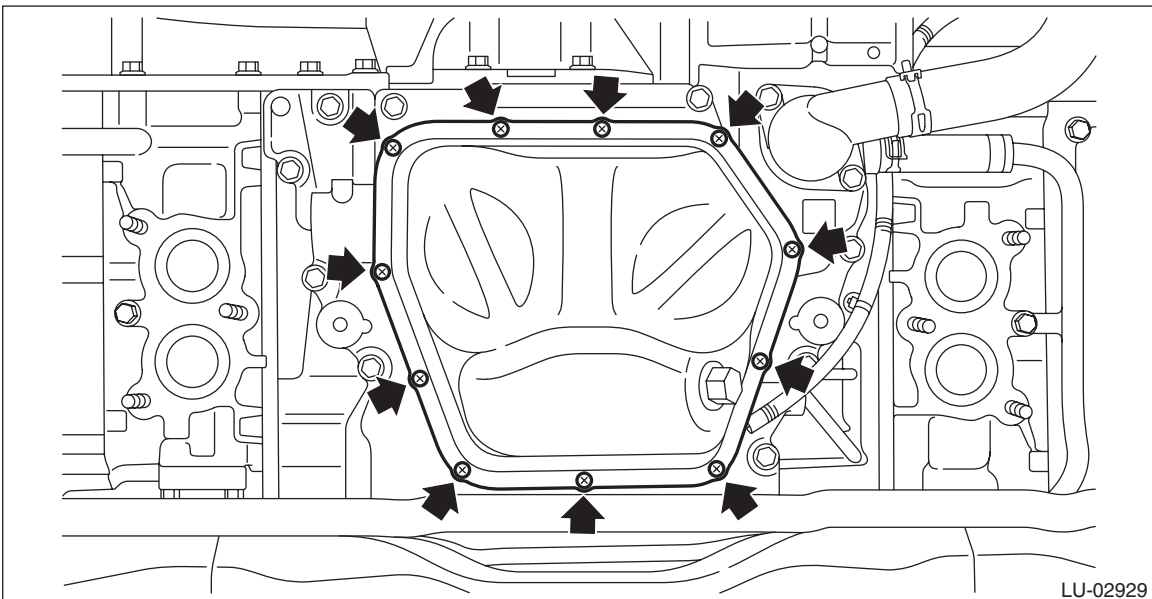

7) Insert an oil pan cutter blade into the gap between oil pan upper and oil pan, and remove the oil pan.

#### **CAUTION:**

**Do not use a screwdriver or similar tool in place of oil pan cutter.**

## 2. OIL PAN UPPER

- 1) Remove the engine from the vehicle. <Ref. to ME(H4DO)-45, REMOVAL, Engine Assembly.>
- 2) Remove the water pump. <Ref. to CO(H4DO)-17, REMOVAL, Water Pump.>
- 3) Remove the thermostat cover. <Ref. to CO(H4DO)-21, REMOVAL, Thermostat.>
- 4) Remove the water pipe assembly. <Ref. to CO(H4DO)-3, WATER PUMP, COMPONENT, General Description.>
- 5) Remove the chain cover. <Ref. to ME(H4DO)-96, REMOVAL, Chain Cover.>
- 6) Remove the oil pan. <Ref. to LU(H4DO)-12, OIL PAN, REMOVAL, Oil Pan and Strainer.>
- 7) Remove clip (A) from the oil pan upper, and remove the oil level switch.

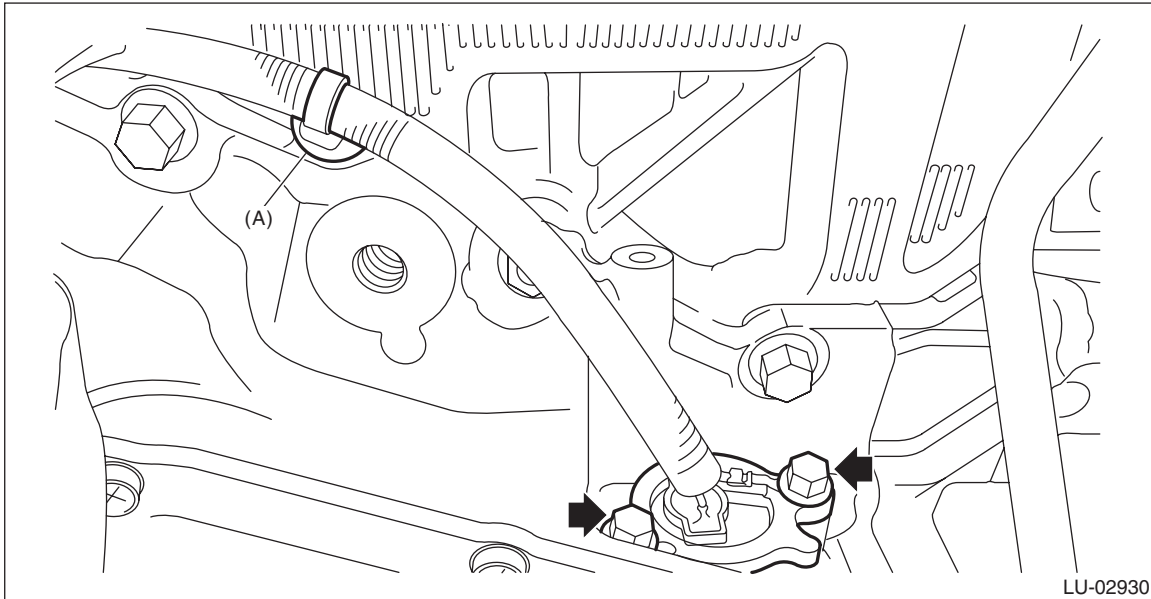

- 8) Remove the bolts which secure oil pan upper to cylinder block, and remove the oil pan upper.

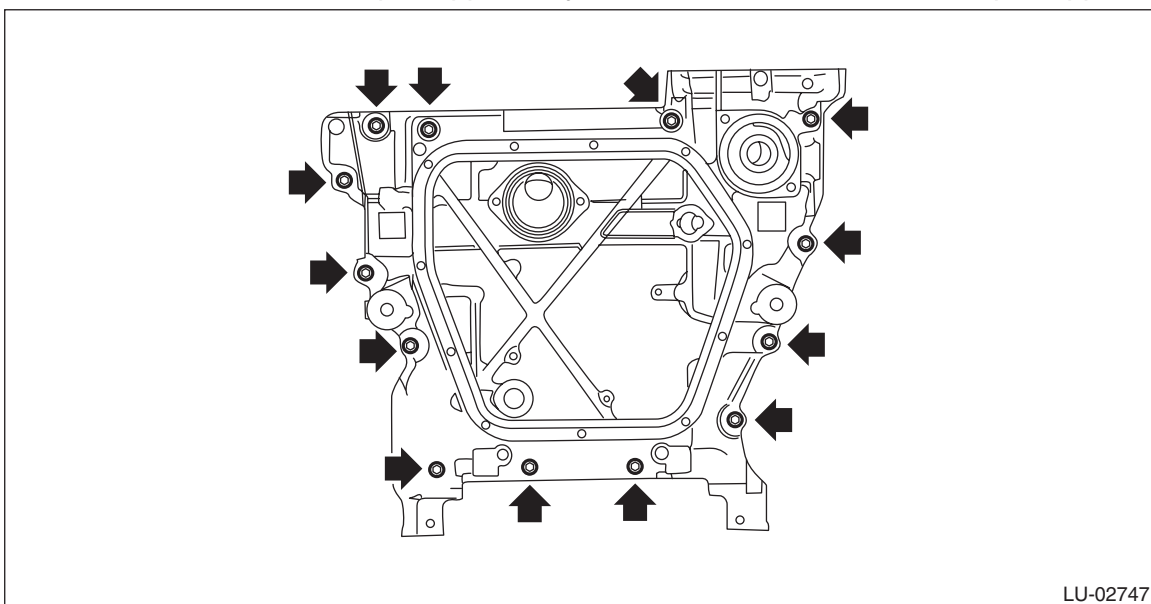

- 9) Remove the baffle plate from the oil pan upper.
- 10) Remove the oil strainer from the oil pan upper.

# Oil Pan and Strainer

## LUBRICATION

11) Remove stud bolts from the oil pan upper.

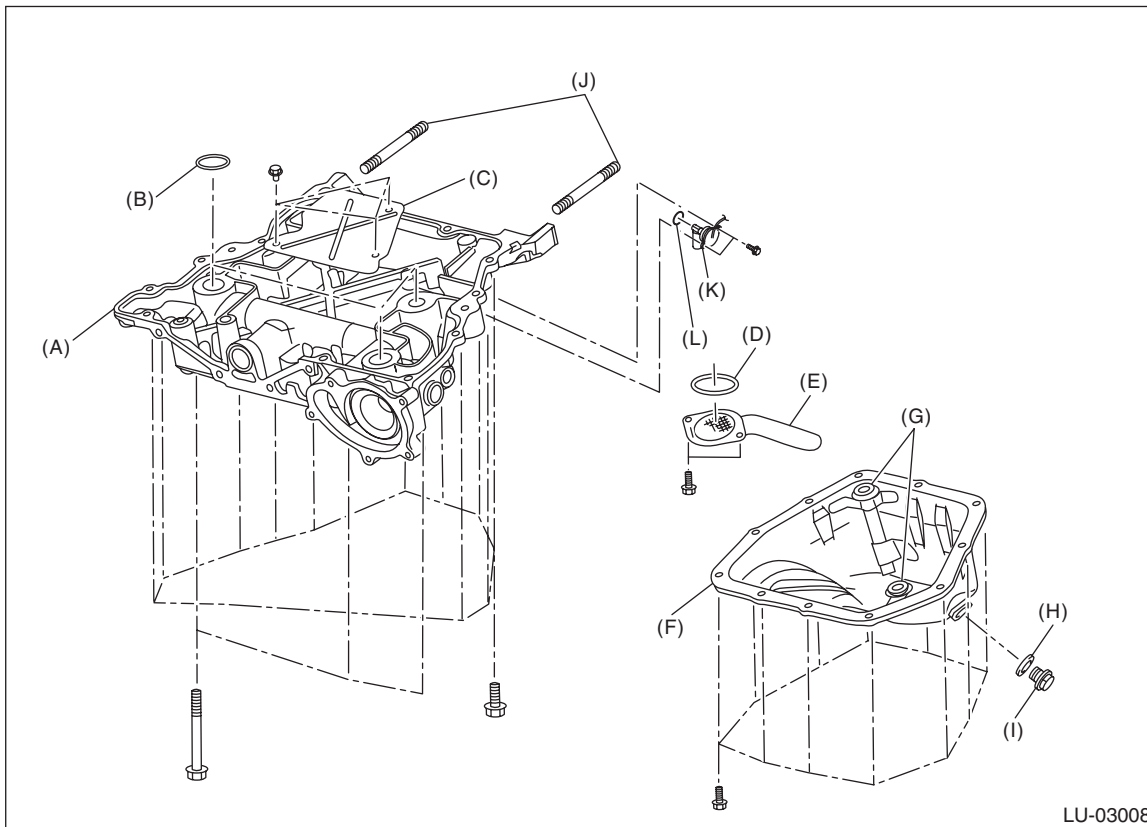

(A) Oil pan upper

(D) O-ring

(G) Oil pan seal ring

(J) Stud bolt

(B) O-ring

(E) Oil strainer

(H) Drain plug gasket

(K) Oil level switch

(C) Baffle plate

(F) Oil pan

(I) Drain plug

(L) O-ring

**B: INSTALLATION****1. OIL PAN**

NOTE:

- Before installing the oil pan, wipe and clean the mating surface of oil pan and oil pan upper.
- Use a new oil pan seal ring.

1) Apply liquid gasket to the mating surfaces of oil pan upper, and install the oil pan.

NOTE:

Install within 5 min. after applying liquid gasket.

**Liquid gasket:**

**THREE BOND 1217G (Part No. K0877Y0100) or equivalent**

**Liquid gasket applying diameter:**

**5±1 mm (0.1969±0.0394 in)**

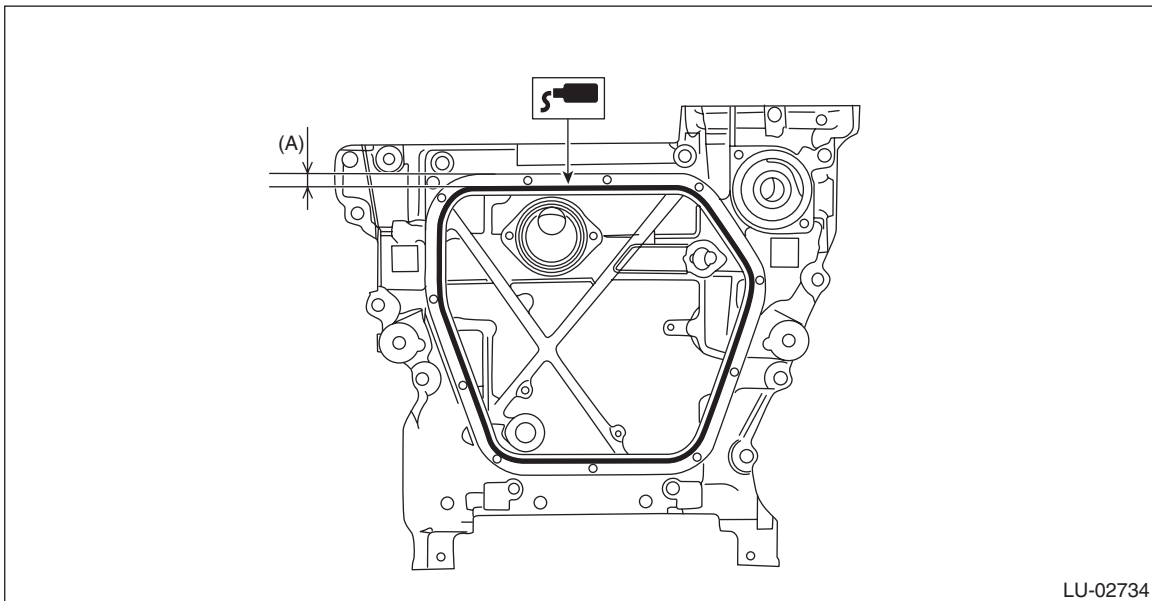

(A) 7.5 mm (0.295 in)

## Oil Pan and Strainer

### LUBRICATION

2) Tighten the bolts to install the oil pan to the oil pan upper in the numerical order.

**Tightening torque:**

**6.4 N·m (0.7 kgf-m, 4.7 ft-lb)**

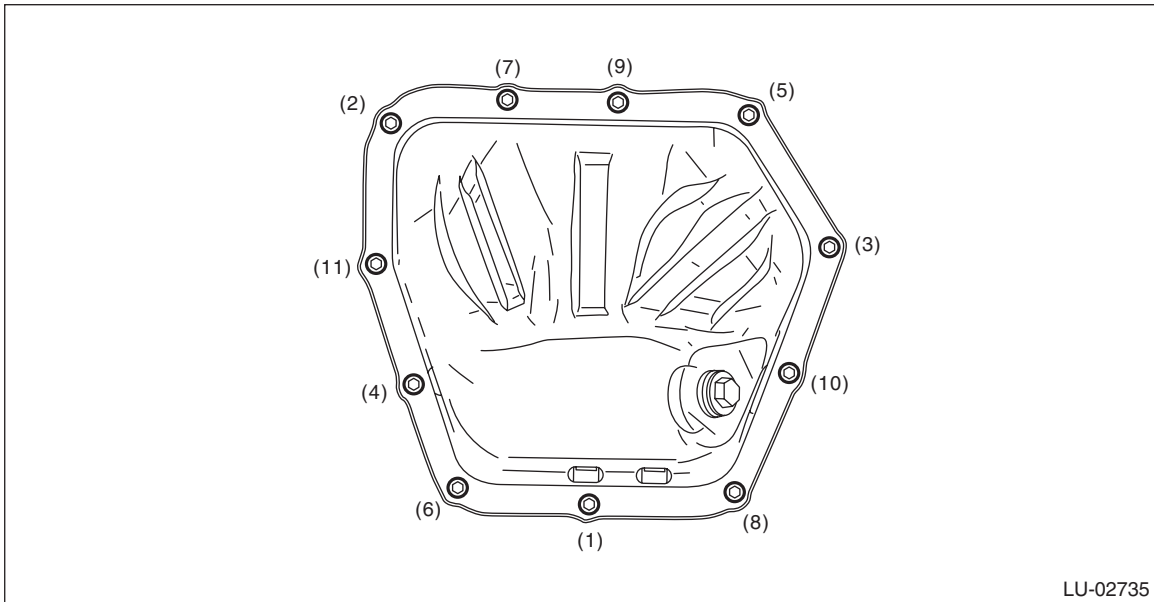

LU-02735

3) Install the front exhaust pipe. <Ref. to EX(H4DO)-8, INSTALLATION, Front Exhaust Pipe.>

4) Install the under cover. <Ref. to EI-33, INSTALLATION, Front Under Cover.>

5) Lower the vehicle.

6) Connect the battery ground terminal.

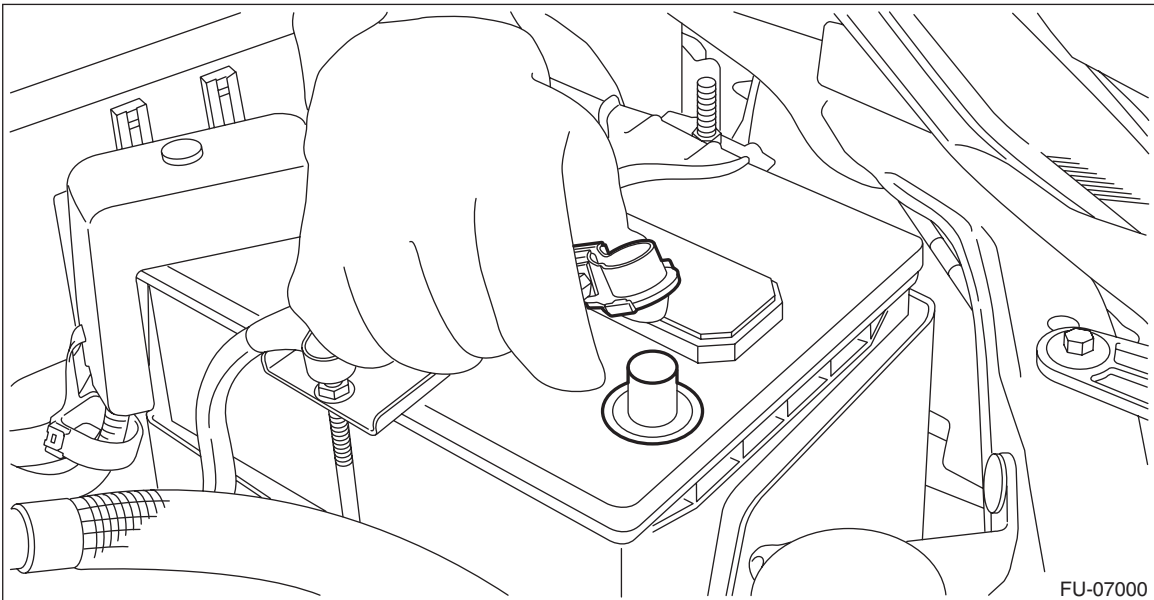

FU-07000

7) Refill the engine oil. <Ref. to LU(H4DO)-9, REPLACEMENT, Engine Oil.>

## 2. OIL PAN UPPER

**NOTE:**

Before installing the oil pan upper, clean the mating surface of oil pan upper and cylinder block.

- 1) Attach the stud bolts to the oil pan upper.
- 2) Attach the oil strainer to the oil pan upper.

**NOTE:**

Use new O-rings.

- 3) Attach the baffle plate to the oil pan upper.

**Tightening torque:**

**T1: 6.4 N·m (0.7 kgf-m, 4.7 ft-lb)**

**T2: 10 N·m (1.0 kgf-m, 7.4 ft-lb)**

**T3: 18 N·m (1.8 kgf-m, 13.3 ft-lb)**

**T4: 41.7 N·m (4.3 kgf-m, 30.8 ft-lb)**

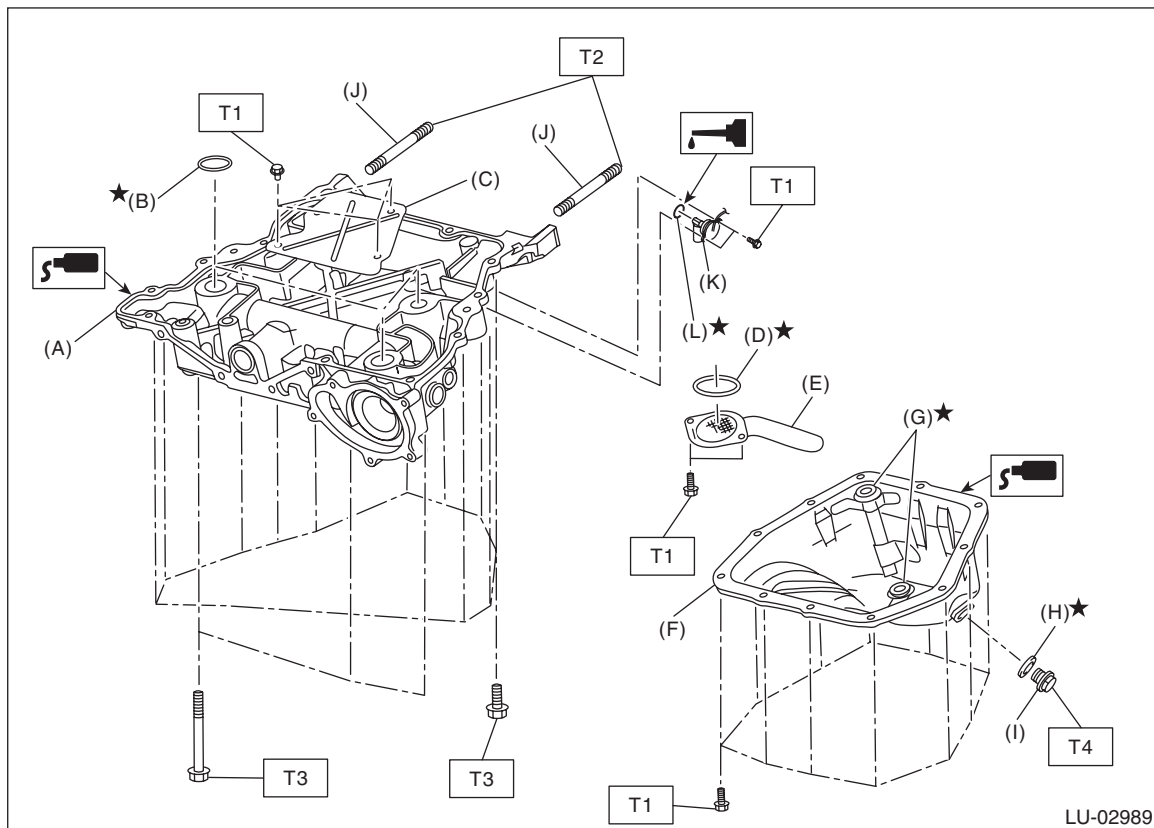

- |                       |                       |                  |
|-----------------------|-----------------------|------------------|
| (A) Oil pan upper     | (B) O-ring            | (C) Baffle plate |
| (D) O-ring            | (E) Oil strainer      | (F) Oil pan      |
| (G) Oil pan seal ring | (H) Drain plug gasket | (I) Drain plug   |
| (J) Stud bolt         | (K) Oil level switch  | (L) O-ring       |

# Oil Pan and Strainer

## LUBRICATION

4) Apply liquid gasket to the mating surface of the oil pan upper as shown in the figure, and install the oil pan upper to the cylinder block.

### CAUTION:

**Be careful not to apply any liquid gasket to the O-ring.**

### NOTE:

- Use new O-rings.
- Install within 5 min. after applying liquid gasket.
- Apply liquid gasket 1.5 mm (0.0591 in) outside from the chamfer surface. However, application of liquid gasket on the chamfer surface around the bolt hole is allowed.

### Liquid gasket:

**THREE BOND 1217G (Part No. K0877Y0100) or equivalent**

### Liquid gasket applying diameter:

**$5 \pm 1$  mm ( $0.1969 \pm 0.0394$  in)**

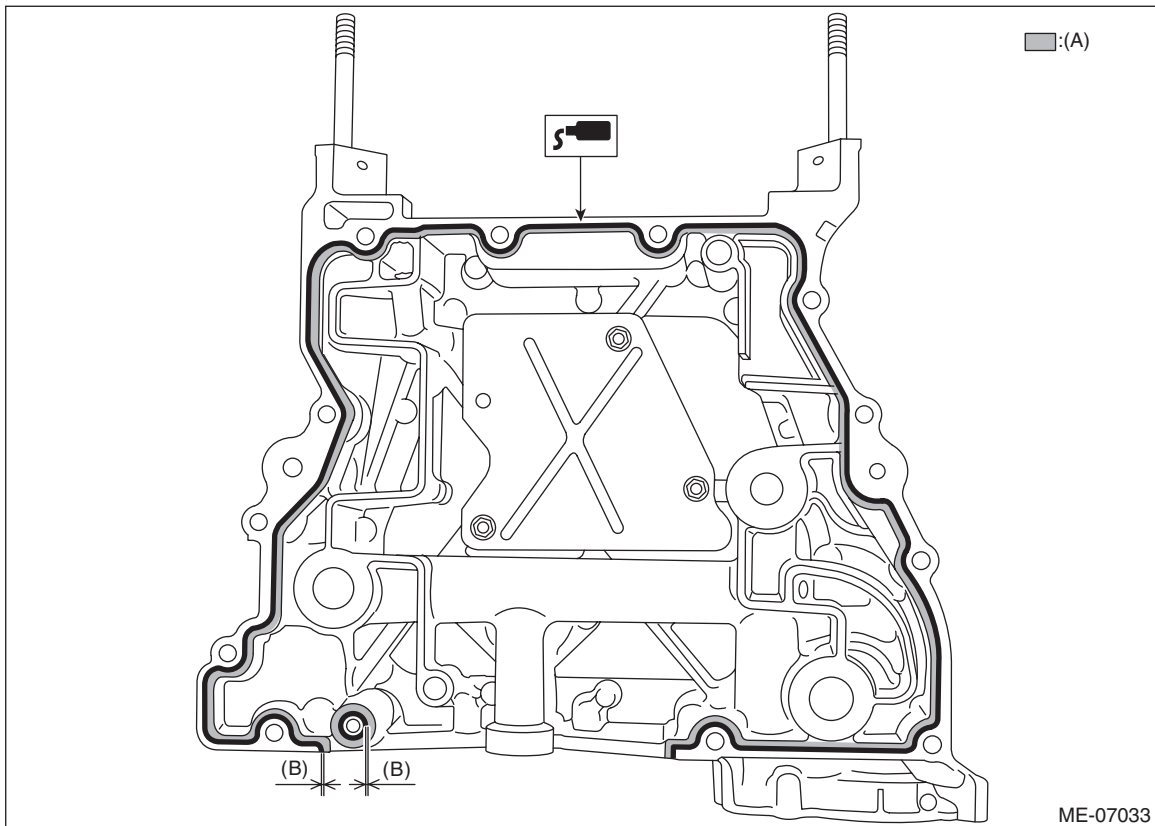

(A) Chamfer surface

(B) 1.5 mm (0.0591 in)

5) Tighten the bolts to install the oil pan upper to the cylinder block in the numerical order.

**NOTE:**

After tightening, if the liquid gasket is squeezed out onto the seal surface of the chain cover, completely remove any squeezed-out liquid gasket.

**Tightening torque:**

**18 N·m (1.8 kgf-m, 13.3 ft-lb)**

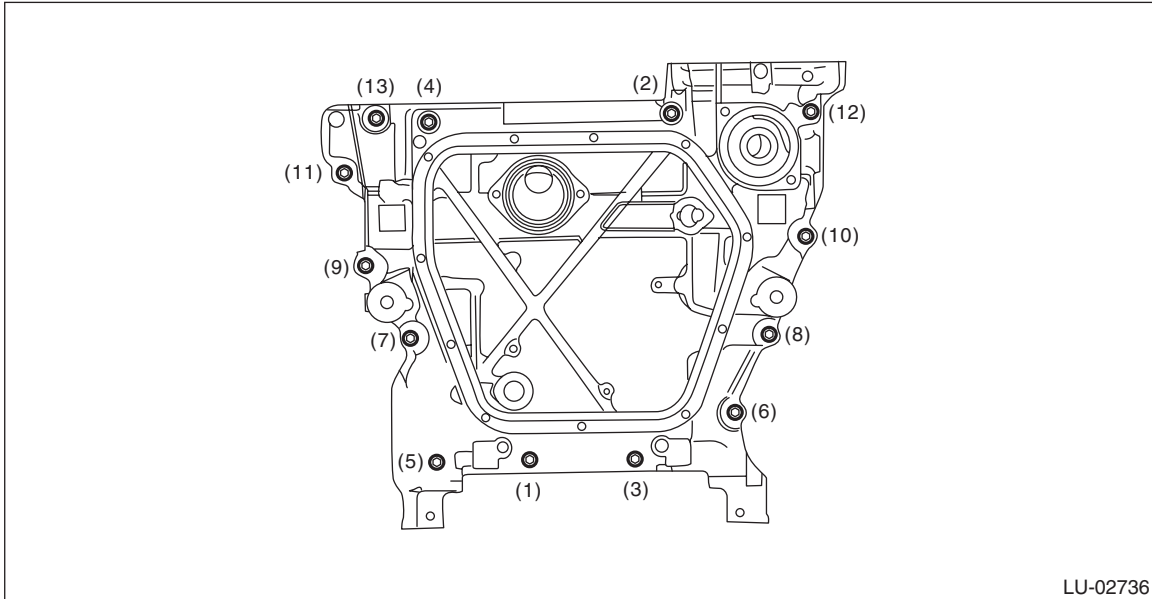

LU-02736

6) Install the oil level switch on the oil pan upper, and secure the harness with clips (A).

**NOTE:**

- Use new O-rings.
- Apply a coat of engine oil to the O-rings.

**Tightening torque:**

**6.4 N·m (0.7 kgf-m, 4.7 ft-lb)**

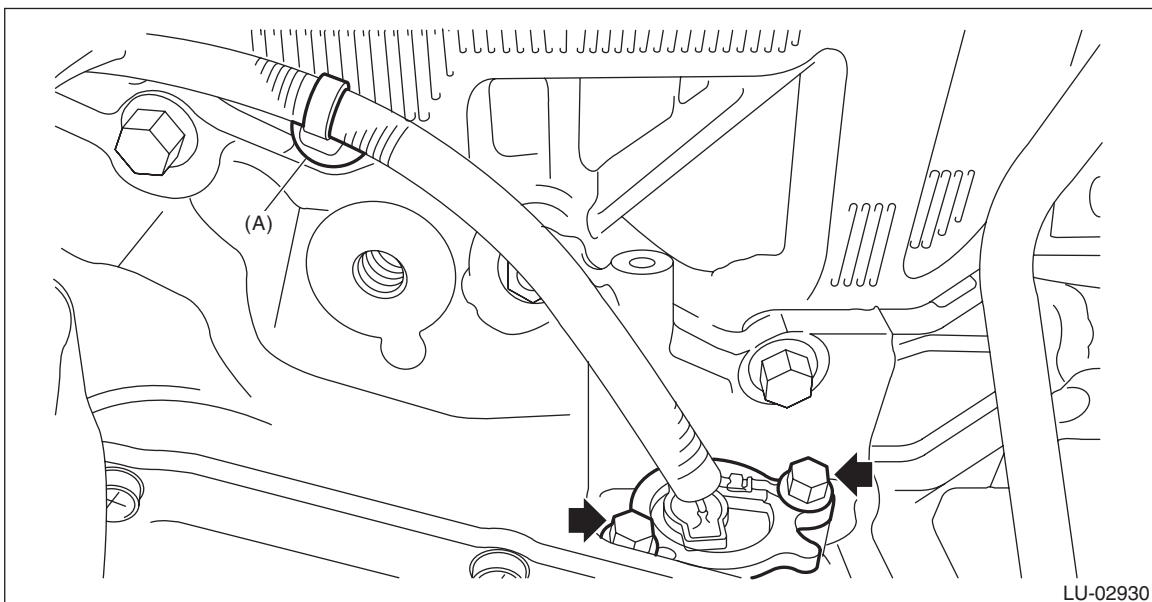

LU-02930



## Oil Pan and Strainer

### LUBRICATION

---

- 7) Install the oil pan. <Ref. to LU(H4DO)-15, OIL PAN, INSTALLATION, Oil Pan and Strainer.>
- 8) Install the chain cover. <Ref. to ME(H4DO)-102, INSTALLATION, Chain Cover.>
- 9) Install the water pipe assembly. <Ref. to CO(H4DO)-3, WATER PUMP, COMPONENT, General Description.>
- 10) Install the thermostat cover. <Ref. to CO(H4DO)-22, INSTALLATION, Thermostat.>
- 11) Install the water pump. <Ref. to CO(H4DO)-18, INSTALLATION, Water Pump.>
- 12) Lower the vehicle.
- 13) Install the engine to the vehicle. <Ref. to ME(H4DO)-58, INSTALLATION, Engine Assembly.>
- 14) Refill the engine oil. <Ref. to LU(H4DO)-9, REPLACEMENT, Engine Oil.>

### **C: INSPECTION**

Check that the oil pan, oil pan upper, oil strainer and baffle plate do not have deformation, cracks or damage.