

General Description

MECHANICAL

1. General Description

A: SPECIFICATION

Engine	Model		2.5 L		
	Cylinder arrangement		Horizontally opposed, liquid cooled, 4-cylinder, 4-stroke gasoline engine		
	Valve system mechanism		Chain driven, double overhead camshaft, 4-valve/cylinder		
	Bore × Stroke		mm (in)	94.0 × 90.0 (3.70 × 3.54)	
	Displacement		cm ³ (cu in)	2.498 (152.43)	
	Compression ratio		10		
	Compression pressure (at 200 — 300 rpm)		kPa (kg/cm ² , psi)	Standard 1,050 — 1,400 (11 — 14, 152 — 203)	
	Number of piston rings		Compression ring: 2 Oil ring: 1		
	Intake valve timing		Open	Max. retard	ATDC 16°
				Min. advance	BTDC 39°
			Close	Max. retard	ABDC 80°
				Min. advance	ABDC 25°
	Exhaust valve timing		Open	BBDC 35°	
			Open	ATDC 13°	
	Cam clearance		mm (in)	Intake	Standard 0.13±0.03 (0.0051±0.0012)
				Exhaust	Standard 0.24±0.03 (0.0094±0.0012)
	Idle speed (For CVT model, select lever in "P" or "N" range. For MT model, gear shift lever in neutral position.)		rpm	No load	Standard CVT model: 675±100 MT model: 650±100
A/C ON				Standard CVT model: 700±100 MT model: 800 — 850±100	
Ignition order		1 → 3 → 2 → 4			
Ignition timing		BTDC/rpm	Standard	CVT model: 16°±10°/675 MT model: 16°±10°/650	

General Description

MECHANICAL

NOTE:

OS: Oversize US: Undersize

Camshaft	Bending		mm (in)	Limit	0.020 (0.00079)
	Cam lobe height	mm (in)	Intake	Standard	40.77 — 40.87 (1.605 — 1.609)
			Exhaust	Standard	40.15 — 40.25 (1.581 — 1.585)
	Cam base circle diameter		mm (in)	Standard	34.0 (1.339)
	Journal outer diameter		mm (in)	Standard	25.946 — 25.963 (1.0215 — 1.0222)
	Thrust clearance		mm (in)	Standard	0.068 — 0.116 (0.0027 — 0.0047)
Oil clearance		mm (in)	Standard	0.037 — 0.072 (0.0015 — 0.0028)	
Cylinder head	Warpage (mating surface with cylinder block)		mm (in)	Limit	0.035 (0.0014)
	Grinding limit		mm (in)		To 98.4 (3.874)
	Height		mm (in)	Standard	98.5 (3.878)
Valve & valve guide	Valve overall length	mm (in)	Intake		103.3 (4.067)
			Exhaust		94.1 (3.705)
	Valve head edge thickness	mm (in)	Intake	Standard	0.8 — 1.2 (0.031 — 0.047)
			Exhaust	Standard	1.0 — 1.4 (0.039 — 0.055)
	Valve stem outer diameter	mm (in)	Intake	Standard	5.455 — 5.470 (0.2148 — 0.2154)
			Exhaust	Standard	5.445 — 5.460 (0.2144 — 0.2150)
	Valve guide inner diameter		mm (in)	Standard	5.500 — 5.512 (0.2165 — 0.2170)
Clearance between valve and valve guide	mm (in)	Intake	Standard	0.030 — 0.057 (0.0012 — 0.0022)	
		Exhaust	Standard	0.040 — 0.067 (0.0016 — 0.0026)	
Valve guide protrusion amount		mm (in)	Standard	11.4 — 11.8 (0.449 — 0.465)	
Valve & valve shim	Valve stem end outer diameter	mm (in)	Intake	Standard	5.455 — 5.470 (0.2148 — 0.2154)
			Exhaust	Standard	5.445 — 5.460 (0.2148 — 0.2150)
	Valve shim inner diameter		mm (in)	Standard	5.500 — 5.560 (0.2165 — 0.2189)
	Clearance between valve and valve shim	mm (in)	Intake	Standard	0.030 — 0.105 (0.0012 — 0.0041)
Exhaust			Standard	0.040 — 0.115 (0.0016 — 0.0045)	
Valve seat	Seating width between valve and valve seat	mm (in)	Intake	Standard	0.8 — 1.6 (0.031 — 0.063)
			Exhaust	Standard	1.1 — 1.7 (0.043 — 0.067)
	Seating angle between valve and valve seat				45°
Seating position between valve and valve seat				Valve face center	
Valve spring	Free length		mm (in)	Standard	41.06 (1.617)
	Tension/spring height	N (kgf, lb)/mm (in)	Set	Standard	182 — 210 (18.56 — 21.41, 40.92 — 47.22)/ 33.0 (1.299)
			Lift	Standard	552 — 610 (56.29 — 62.20, 124.11 — 137.15)/ 22.0 (0.866)
Squareness			Standard	2.5°, 1.8 mm (0.071 in) or less	

General Description

MECHANICAL

Cylinder block & piston	Cylinder block warpage (Mating surface with cylinder head)		mm (in)	Limit	0.025 (0.00098)	
	Grinding limit of cylinder block			mm (in)	To 204.9 (8.067)	
	Height of cylinder block		mm (in)	Standard	205.0 (8.071)	
	Inner diameter of cylinder liner	mm (in)	Cylinder bore size mark A	Standard	94.005 — 94.015 (3.7010 — 3.7014)	
			Cylinder bore size mark B	Standard	93.995 — 94.005 (3.7006 — 3.7010)	
	Cylindricity of cylinder liner		mm (in)	Limit	0.015 (0.0006)	
	Out-of-roundness of cylinder liner		mm (in)	Limit	0.010 (0.0004)	
	Piston grade point			mm (in)	13.3 (0.52)	
	Piston outer diameter	mm (in)	Standard Size	Grade A	Standard	93.980 — 93.990 (3.7000 — 3.7004)
				Grade B	Standard	93.970 — 93.980 (3.6996 — 3.7000)
			0.25 (0.0098) OS		Standard	94.220 — 94.240 (3.7094 — 3.7102)
			0.50 (0.0197) OS		Standard	94.470 — 94.490 (3.7193 — 3.7201)
	Clearance between cylinder liner and piston		mm (in)	Standard	0.015 — 0.035 (0.00059 — 0.00138)	
Inner diameter of cylinder liner boring limit (diameter)			mm (in)	To 94.505 (3.7207)		
Piston and piston pin	Degree of fit			Piston pin must be fitted into position with thumb at 20°C (68°F).		
	Clearance between piston and piston pin		mm (in)	Standard	0.004 — 0.008 (0.0002 — 0.0003)	
Piston ring	Closed gap	mm (in)	Compression ring	Top ring	Standard	0.20 — 0.30 (0.0079 — 0.0118)
				Second ring	Standard	0.30 — 0.45 (0.0118 — 0.0177)
		Oil ring (upper rail and lower rail)		Standard	0.20 — 0.50 (0.0079 — 0.0197)	
	Clearance between compression ring and piston	mm (in)	Top ring	Standard	0.040 — 0.080 (0.0016 — 0.0031)	
Second ring			Standard	0.030 — 0.070 (0.0012 — 0.0028)		
Connecting rod and connecting rod bearing	Bend or twist per 100 mm (3.94 in) in length		mm (in)	Limit	0.10 (0.0039)	
	Thrust clearance		mm (in)	Standard	0.070 — 0.330 (0.0028 — 0.0130)	
	Connecting rod bearing thickness (at center)	mm (in)	Standard size	Standard	1.492 — 1.508 (0.0587 — 0.0594)	
			0.03 (0.0012) US	Standard	1.511 — 1.515 (0.0595 — 0.0596)	
			0.05 (0.0020) US	Standard	1.521 — 1.525 (0.0599 — 0.0600)	
			0.25 (0.0098) US	Standard	1.621 — 1.625 (0.0638 — 0.0640)	
Oil clearance		mm (in)	Standard	0.017 — 0.047 (0.0007 — 0.0019)		
Piston pin & connecting rod bushing	Clearance between piston pin and connecting rod bushing		mm (in)	Standard	0.004 — 0.026 (0.0002 — 0.0010)	

General Description

MECHANICAL

Crankshaft and crankshaft bearing	Bending		mm (in)	Limit	0.035 (0.0014)		
	Crankshaft pin	Cylindricity	mm (in)	Limit	0.006 (0.0002)		
		Out-of-roundness	mm (in)	Limit	0.005 (0.0002)		
		Grinding limit (dia.)		mm (in)	To 47.726 (1.8790)		
		Grinding limit (dia.)		mm (in)	To 47.726 (1.8790)		
	Crankshaft journal	Cylindricity	mm (in)	Limit	0.006 (0.0002)		
		Out-of-roundness	mm (in)	Limit	0.005 (0.0002)		
		Grinding limit (dia.)		mm (in)	To 67.735 (2.6667)		
		Grinding limit (dia.)		mm (in)	To 67.735 (2.6667)		
	Crankshaft pin outer diameter	mm (in)	Standard size	Standard	47.976 — 48.000 (1.8888 — 1.8898)		
			0.03 (0.0012) US	Standard	47.946 — 47.970 (1.8876 — 1.8886)		
			0.05 (0.0020) US	Standard	47.926 — 47.950 (1.8868 — 1.8878)		
			0.25 (0.0098) US	Standard	47.726 — 47.750 (1.8790 — 1.8799)		
	Crankshaft journal outer diameter	mm (in)	Standard size	Standard	67.985 — 68.009 (2.6766 — 2.6775)		
			0.03 (0.0012) US	Standard	67.955 — 67.979 (2.6754 — 2.6763)		
			0.05 (0.0020) US	Standard	67.935 — 67.959 (2.6746 — 2.6755)		
			0.25 (0.0098) US	Standard	67.735 — 67.759 (2.6667 — 2.6677)		
	Crankshaft bearing thickness (at center)	#1, #2, #3, #4	mm (in)	Standard size	Standard	2.495 — 2.513 (0.0982 — 0.0989)	
				0.03 (0.0012) US	Standard	2.519 — 2.522 (0.0992 — 0.0993)	
				0.05 (0.0020) US	Standard	2.529 — 2.532 (0.0996 — 0.0997)	
0.25 (0.0098) US				Standard	2.629 — 2.632 (0.1035 — 0.1036)		
#5		mm (in)	Standard size	Standard	2.493 — 2.511 (0.0981 — 0.0989)		
			0.03 (0.0012) US	Standard	2.517 — 2.520 (0.0991 — 0.0992)		
			0.05 (0.0020) US	Standard	2.527 — 2.530 (0.0995 — 0.0996)		
			0.25 (0.0098) US	Standard	2.627 — 2.630 (0.1034 — 0.1035)		
Thrust clearance		mm (in)	Standard	0.130 — 0.308 (0.00512 — 0.01213)			
Oil clearance		mm (in)	Standard	0.013 — 0.031 (0.00051 — 0.00122)			

General Description

MECHANICAL

B: COMPONENT

1. TIMING CHAIN & CAMSHAFT

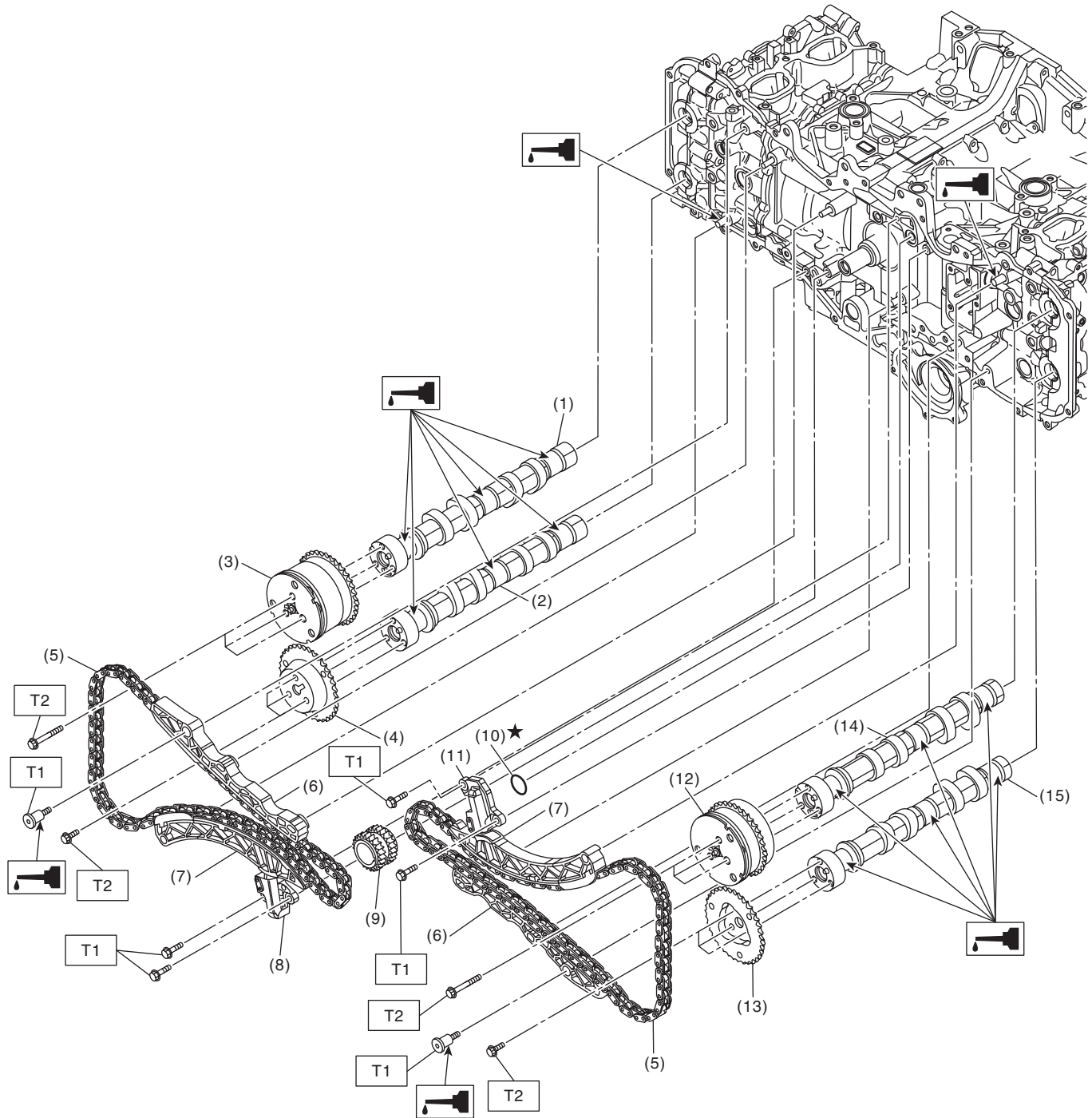

ME-07071

General Description

MECHANICAL

-
- | | | |
|-----------------------------|------------------------------|--------------------------|
| (1) Intake camshaft RH | (8) Chain tensioner RH | (14) Intake camshaft LH |
| (2) Exhaust camshaft RH | (9) Crank sprocket | (15) Exhaust camshaft LH |
| (3) Intake cam sprocket RH | (10) O-ring | |
| (4) Exhaust cam sprocket RH | (11) Chain tensioner LH | |
| (5) Timing chain | (12) Intake cam sprocket LH | |
| (6) Chain guide | (13) Exhaust cam sprocket LH | |
| (7) Chain tension lever | | |

Tightening torque: N·m (kgf·m, ft·lb)

T1: 6.4 (0.7, 4.7)

T2: 18 (1.8, 13.3)

General Description

MECHANICAL

2. CHAIN COVER

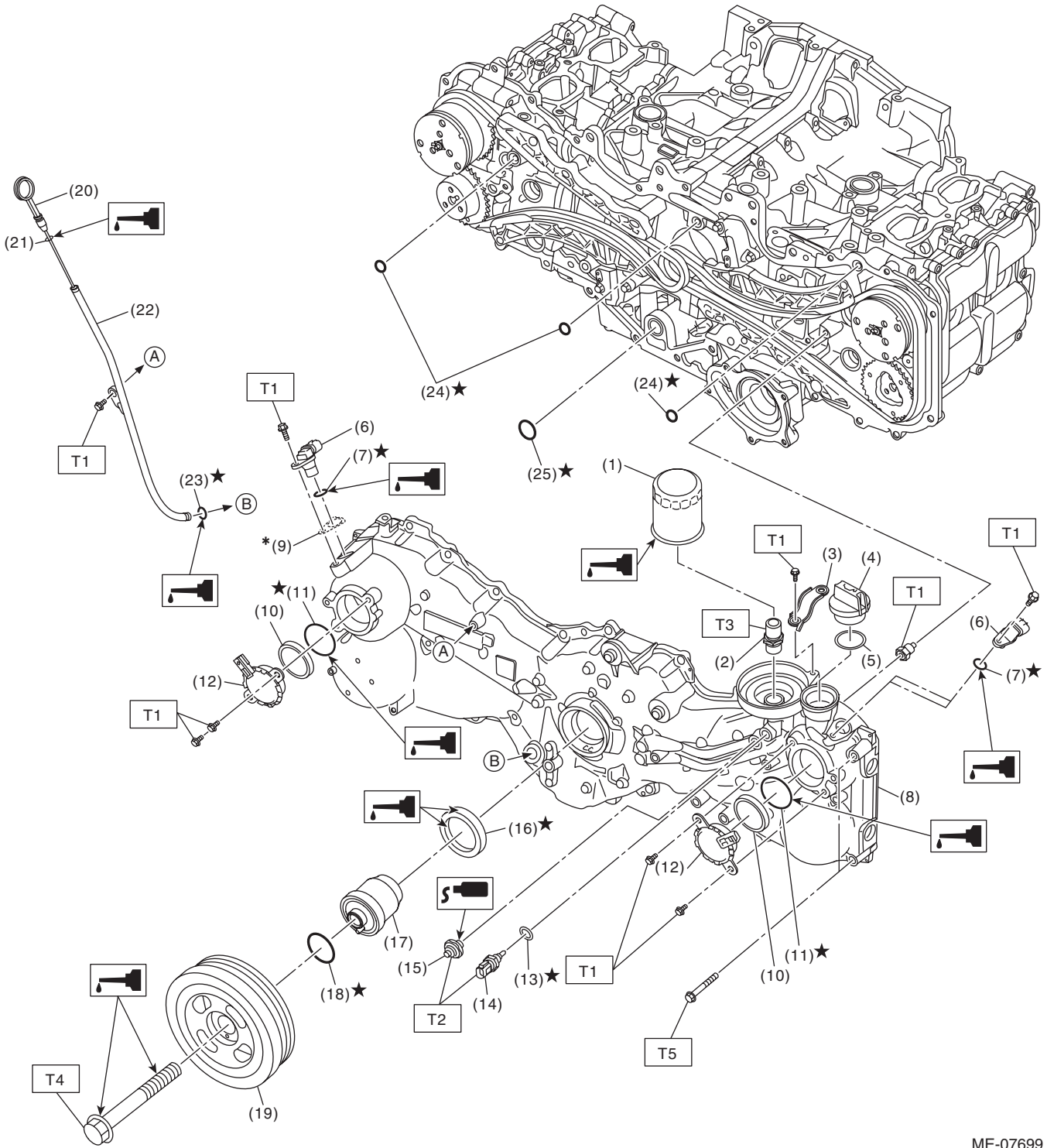

ME-07699

ME(H4DO)-8

- | | | |
|------------------------------|------------------------------------|-------------|
| (1) Oil filter | (12) Oil control solenoid | (23) O-ring |
| (2) Oil pump union | (13) Gasket | (24) O-ring |
| (3) Generator cord stay | (14) Engine oil temperature sensor | (25) O-ring |
| (4) Oil filler cap | (15) Oil pressure switch | |
| (5) Gasket | (16) Front oil seal | |
| (6) Camshaft position sensor | (17) Crank pulley boss | |
| (7) O-ring | (18) O-ring | |
| (8) Chain cover | (19) Crank pulley | |
| (9) Spacer | (20) Oil level gauge | |
| (10) Back-up ring | (21) O-ring | |
| (11) O-ring | (22) Oil level gauge guide | |

* Zero or one spacer for gap adjustment.

Tightening torque: N·m (kgf·m, ft·lb)

T1: 6.4 (0.7, 4.7)

T2: 18 (1.8, 13.3)

T3: 45 (4.6, 33.2)

T4: <Ref. to ME(H4DO)-89, INSTALLATION, Crank Pulley.>

T5: <Ref. to ME(H4DO)-102, INSTALLATION, Chain Cover.>

3. ROCKER COVER

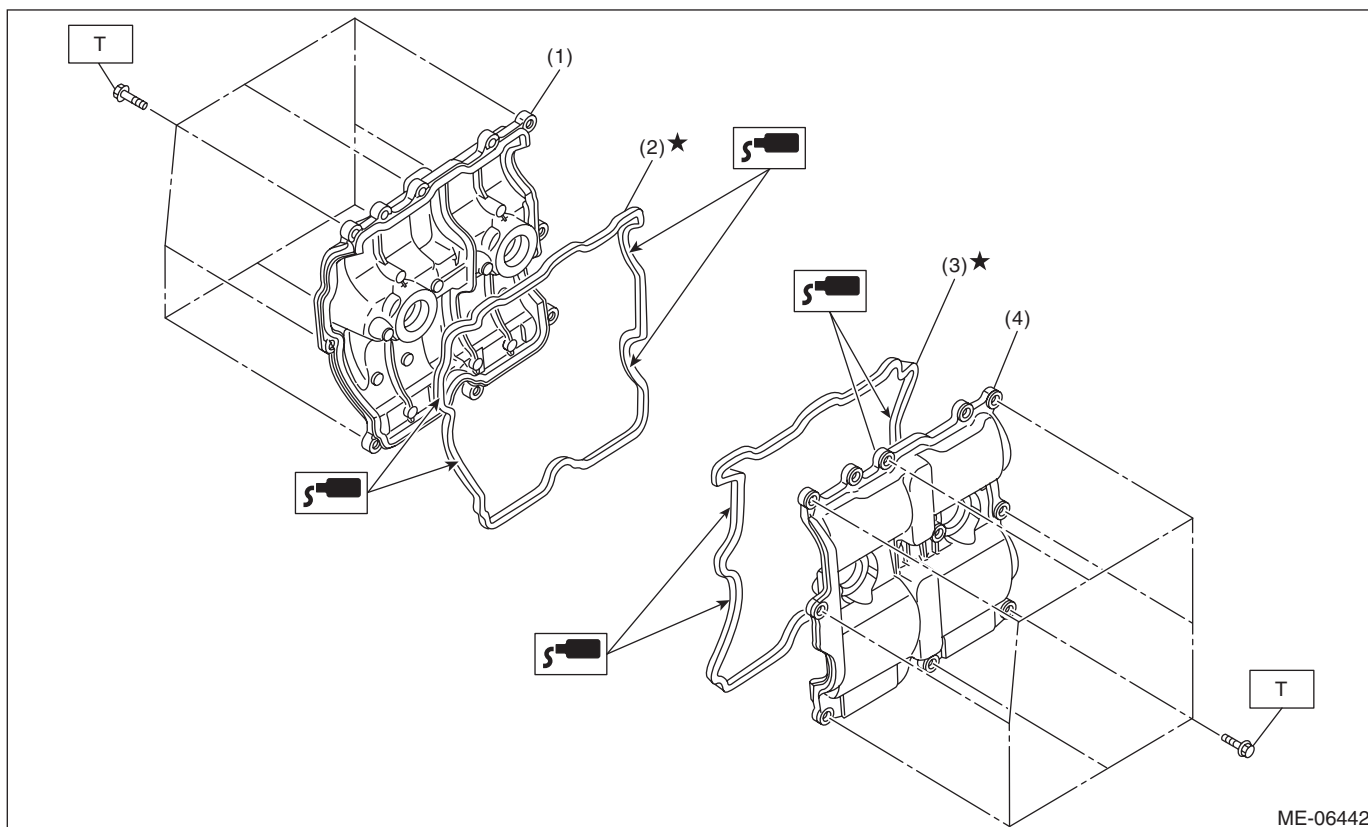

- | | |
|----------------------------|----------------------------|
| (1) Rocker cover RH | (3) Rocker cover gasket LH |
| (2) Rocker cover gasket RH | (4) Rocker cover LH |

Tightening torque: N·m (kgf·m, ft·lb)

T: <Ref. to ME(H4DO)-149, INSTALLATION, Rocker Cover.>

General Description

MECHANICAL

4. CAM CARRIER

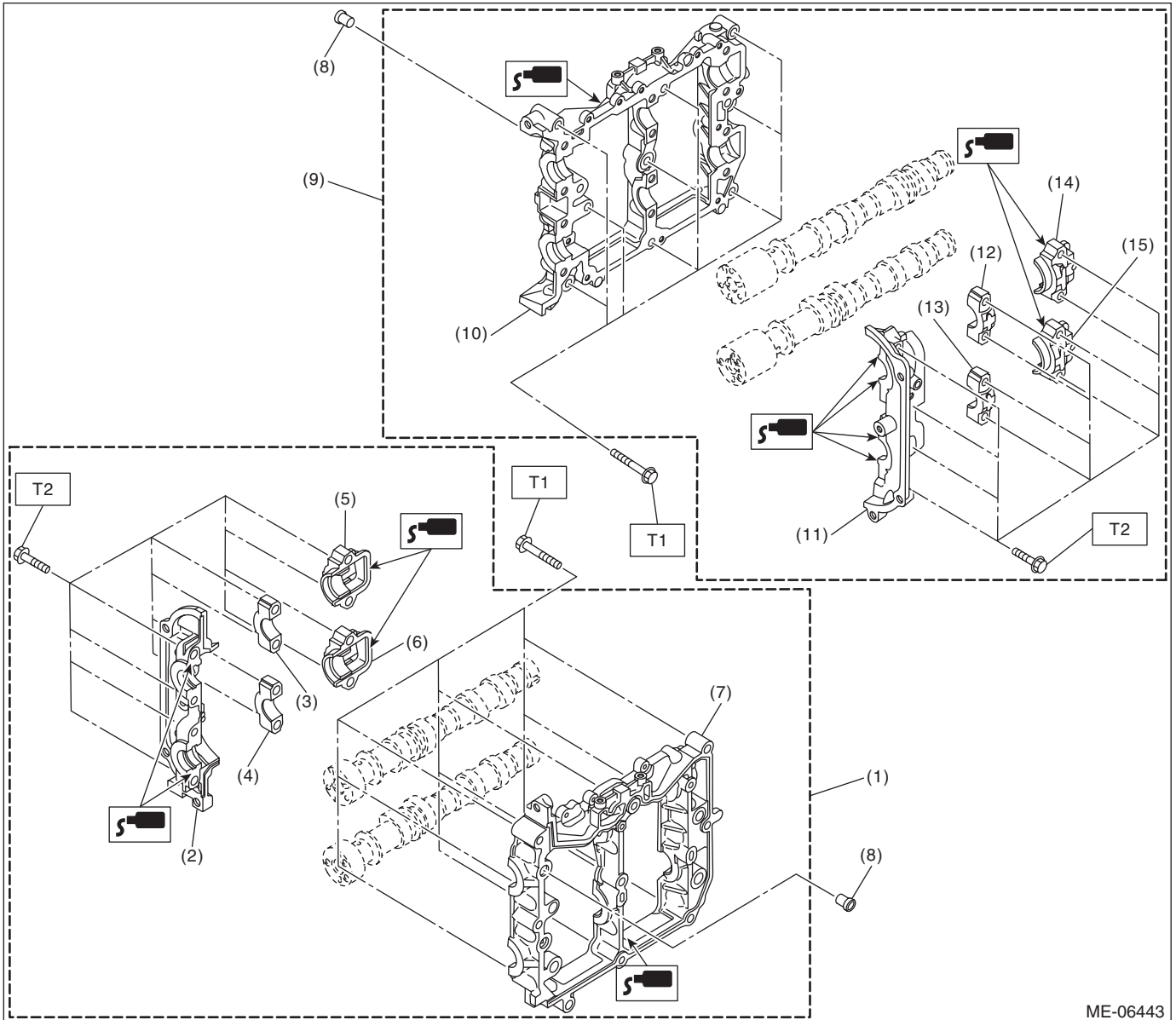

ME-06443

- | | | |
|------------------------------------|-------------------------------------|-----------------------------------|
| (1) Cam carrier ASSY | (8) Filter | (14) Intake rear camshaft cap LH |
| (2) Front camshaft cap RH | (9) Cam carrier ASSY | (15) Exhaust rear camshaft cap LH |
| (3) Intake center camshaft cap RH | (10) Cam carrier LH | |
| (4) Exhaust center camshaft cap RH | (11) Front camshaft cap LH | |
| (5) Intake rear camshaft cap RH | (12) Intake center camshaft cap LH | |
| (6) Exhaust rear camshaft cap RH | (13) Exhaust center camshaft cap LH | |
| (7) Cam carrier RH | | |

Tightening torque: N·m (kgf-m, ft-lb)

T1: <Ref. to ME(H4DO)-192, ASSEMBLY, Cam Carrier.>

T2: <Ref. to ME(H4DO)-168, INSTALLATION, Cam Carrier.>

5. CYLINDER HEAD

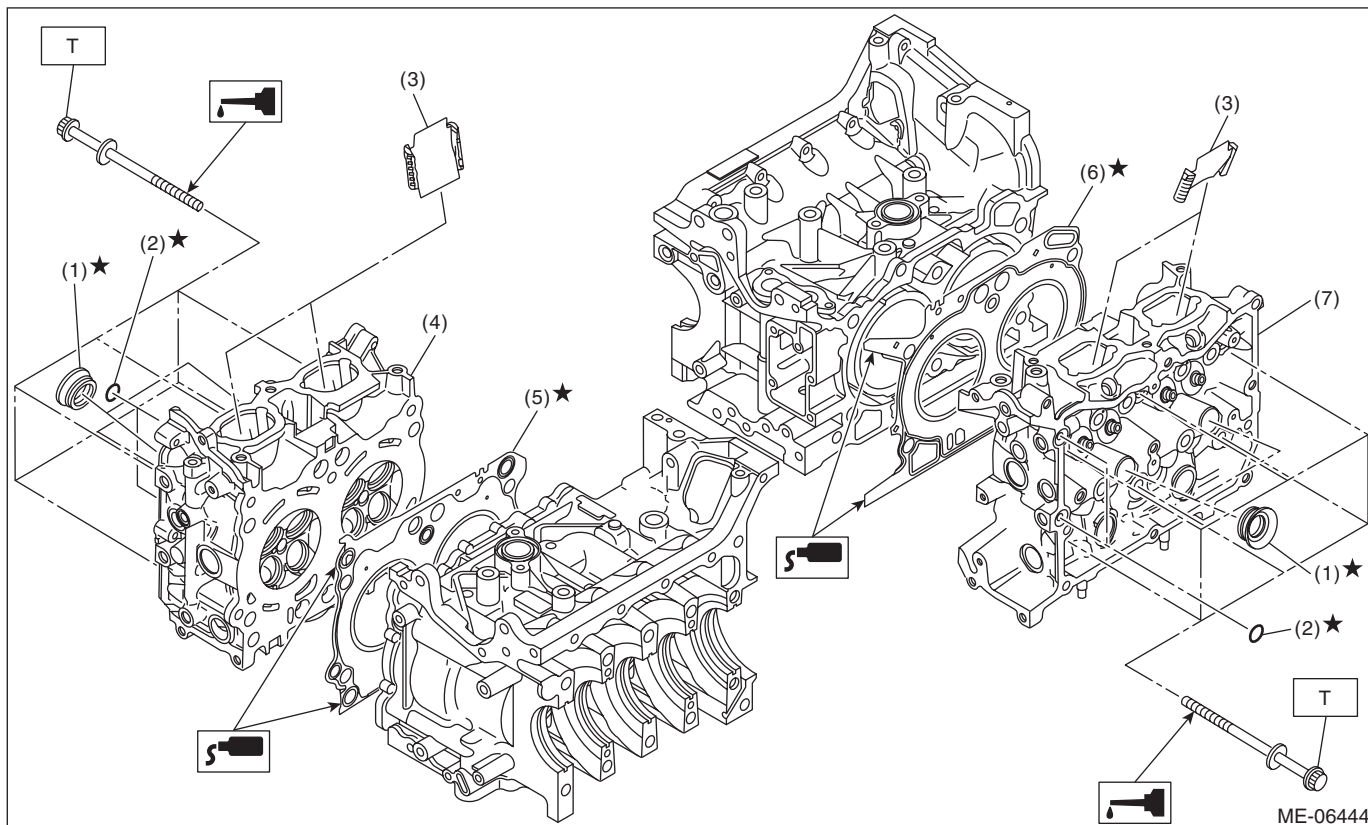

- | | |
|----------------------------|-----------------------------|
| (1) Spark plug pipe gasket | (5) Cylinder head gasket RH |
| (2) O-ring | (6) Cylinder head gasket LH |
| (3) Cylinder head plate | (7) Cylinder head LH |
| (4) Cylinder head RH | |

Tightening torque: N·m (kgf-m, ft-lb)

T: <Ref. to ME(H4DO)-205, INSTALLATION, Cylinder Head.>

General Description

MECHANICAL

6. VALVE ASSY

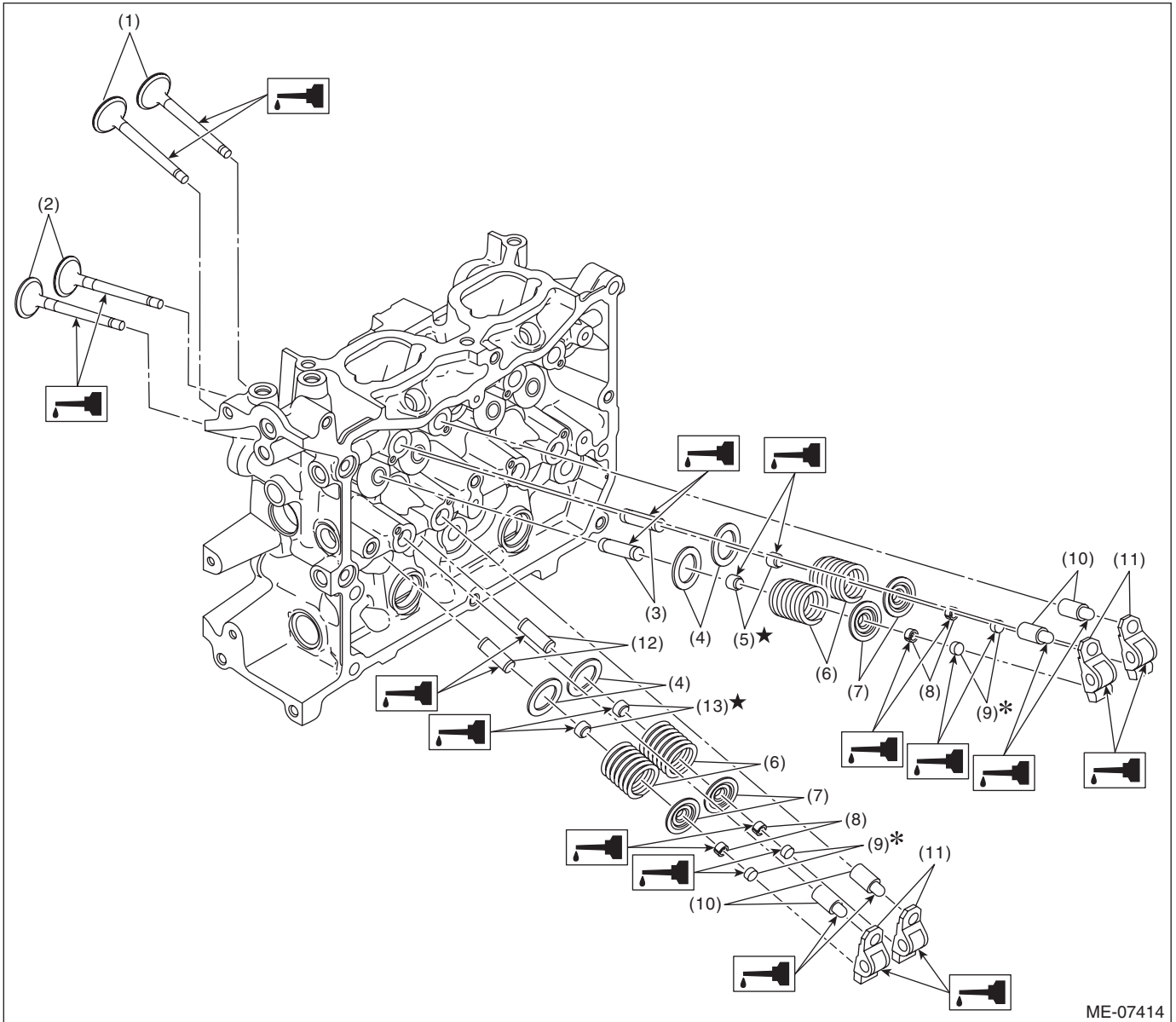

ME-07414

- | | | |
|---------------------------|------------------------------|-----------------------------|
| (1) Exhaust valve | (6) Valve spring | (11) Roller rocker arm |
| (2) Intake valve | (7) Valve spring retainer | (12) Exhaust valve guide |
| (3) Intake valve guide | (8) Valve collet | (13) Exhaust valve oil seal |
| (4) Valve spring seat | (9) Valve shim | |
| (5) Intake valve oil seal | (10) Roller rocker arm pivot | |

7. CYLINDER BLOCK 1

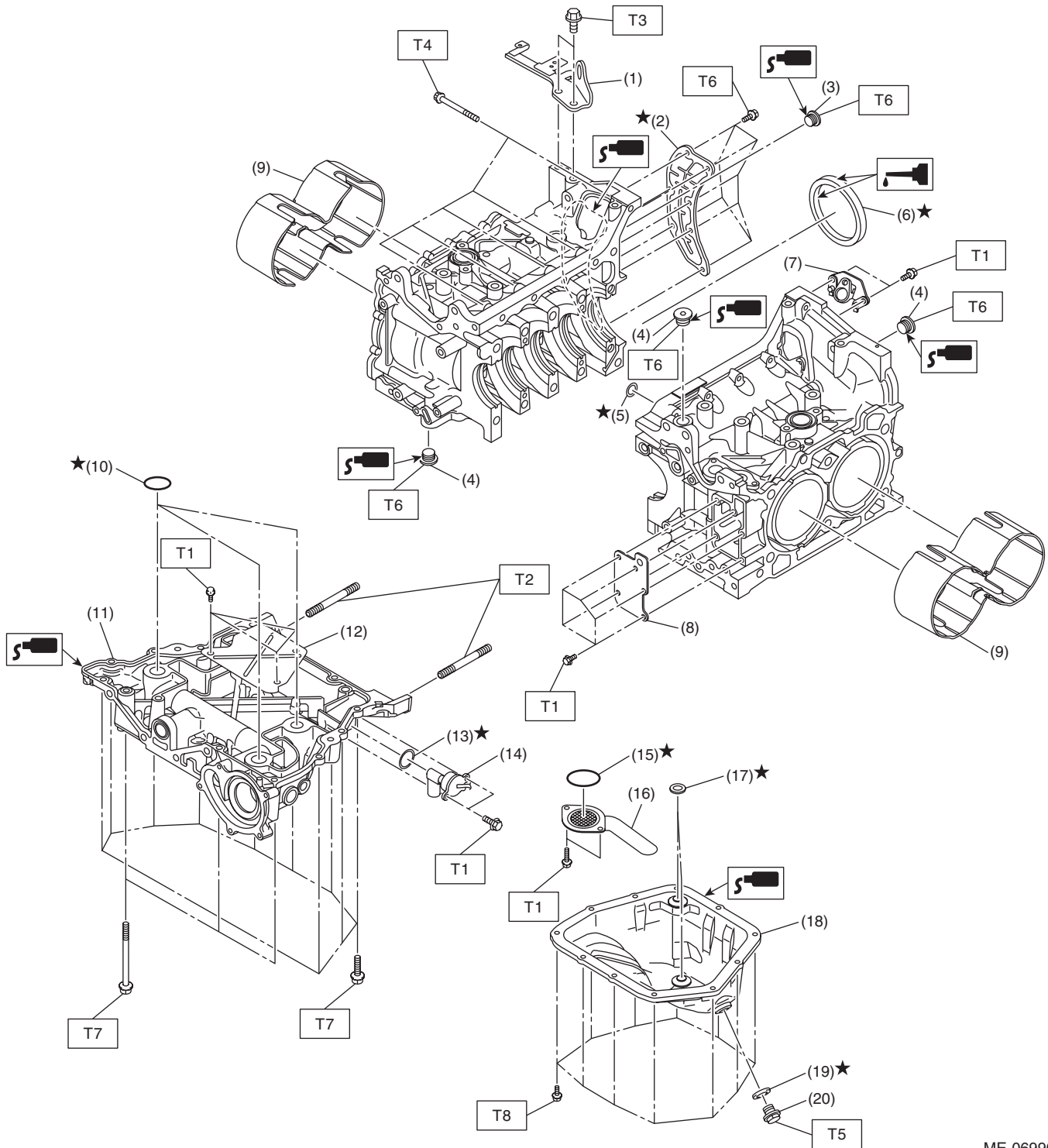

ME-06990

General Description

MECHANICAL

- | | |
|---------------------------------------|------------------------|
| (1) Engine rear hanger | (11) Oil pan upper |
| (2) Oil separator cover | (12) Baffle plate |
| (3) Cylinder block plug | (13) O-ring |
| (4) Main gallery plug | (14) Oil level switch |
| (5) O-ring | (15) O-ring |
| (6) Rear oil seal | (16) Oil strainer |
| (7) Crankshaft position sensor holder | (17) Oil pan seal ring |
| (8) Cylinder block plate | (18) Oil pan |
| (9) Water jacket spacer | (19) Drain plug gasket |
| (10) O-ring | (20) Drain plug |

Tightening torque: N·m (kgf-m, ft-lb)**T1: 6.4 (0.7, 4.7)****T2: 10 (1.0, 7.4)****T3: 21 (2.1, 15.5)****T4: 25 (2.5, 18.4)****T5: 41.7 (4.3, 30.8)****T6: <Ref. to ME(H4DO)-307, CYLINDER BLOCK, ASSEMBLY, Cylinder Block.>****T7: <Ref. to ME(H4DO)-261, INSTALLATION, Cylinder Block.>****T8: <Ref. to LU(H4DO)-15, OIL PAN, INSTALLATION, Oil Pan and Strainer.>**

8. CYLINDER BLOCK 2

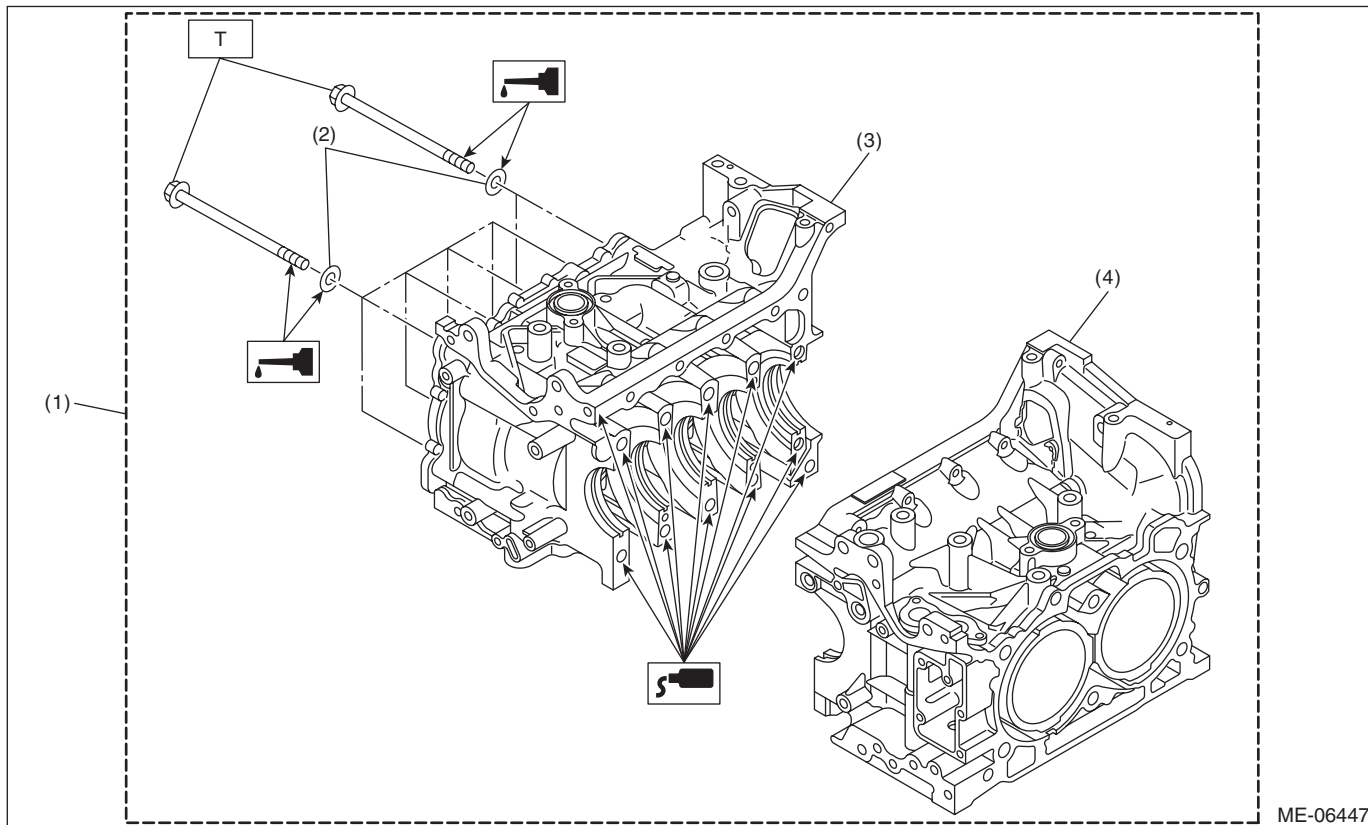

(1) Cylinder block ASSY

(2) Washer

(3) Cylinder block RH

(4) Cylinder block LH

Tightening torque: N·m (kgf·m, ft·lb)

**T: <Ref. to ME(H4DO)-261,
INSTALLATION, Cylinder
Block.>**

General Description

MECHANICAL

9. CRANKSHAFT AND PISTON

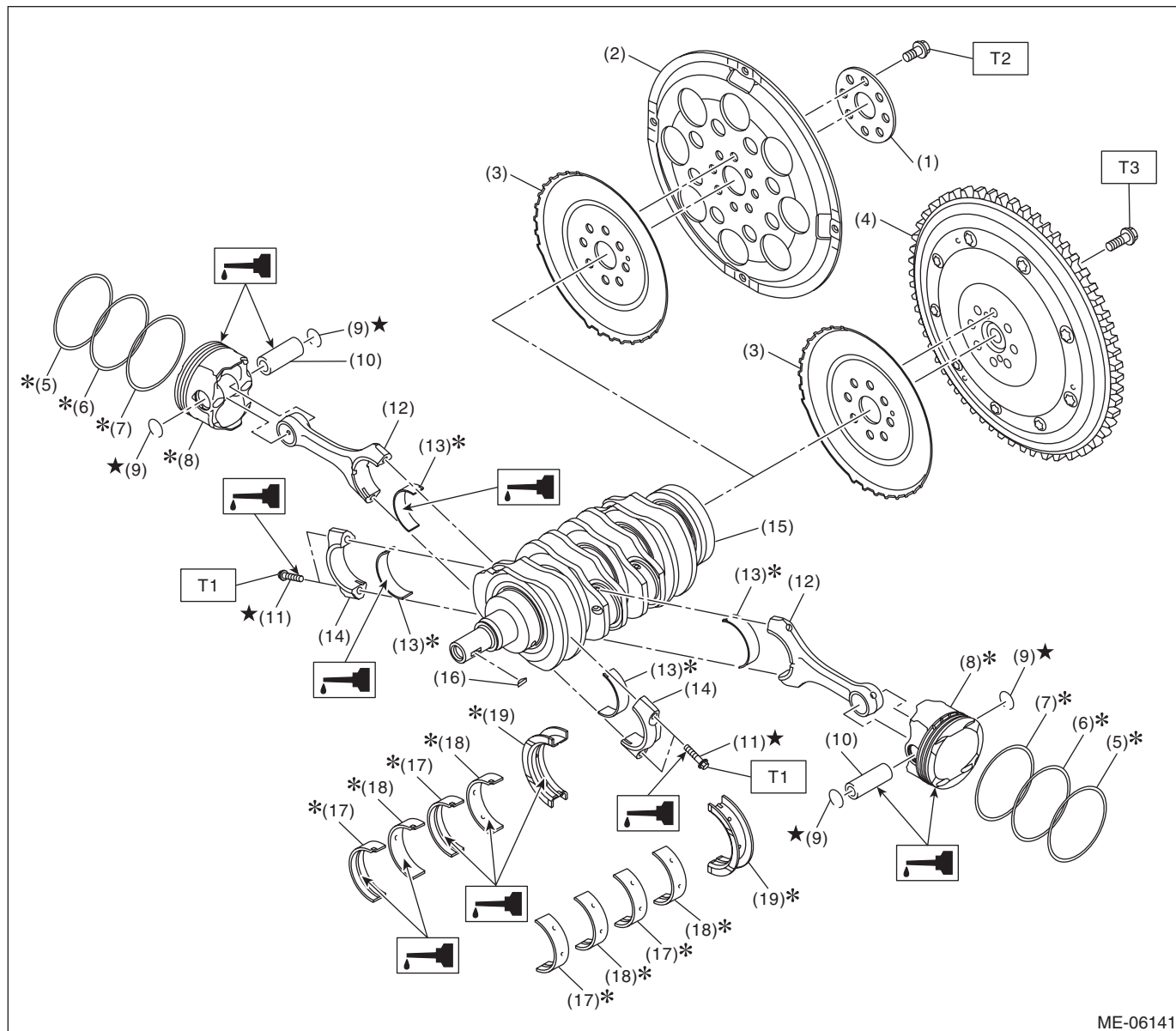

- | | | |
|---|------------------------------|--------------------------------|
| (1) Reinforcement drive plate (CVT model) | (9) Circlip | (17) Crankshaft bearing #1, #3 |
| (2) Drive plate (CVT model) | (10) Piston pin | (18) Crankshaft bearing #2, #4 |
| (3) Crankshaft position sensor plate | (11) Connecting rod cap bolt | (19) Crankshaft bearing #5 |
| (4) Flywheel (MT model) | (12) Connecting rod | |
| (5) Top ring | (13) Connecting rod bearing | |
| (6) Second ring | (14) Connecting rod cap | |
| (7) Oil ring | (15) Crankshaft | |
| (8) Piston | (16) Woodruff key | |

Tightening torque: N·m (kgf·m, ft·lb)

T1: <Ref. to ME(H4DO)-261, INSTALLATION, Cylinder Block.>

T2: <Ref. to CVT-157, INSTALLATION, Drive Plate.>

T3: <Ref. to CL-13, INSTALLATION, Flywheel.>

10.ENGINE MOUNTING

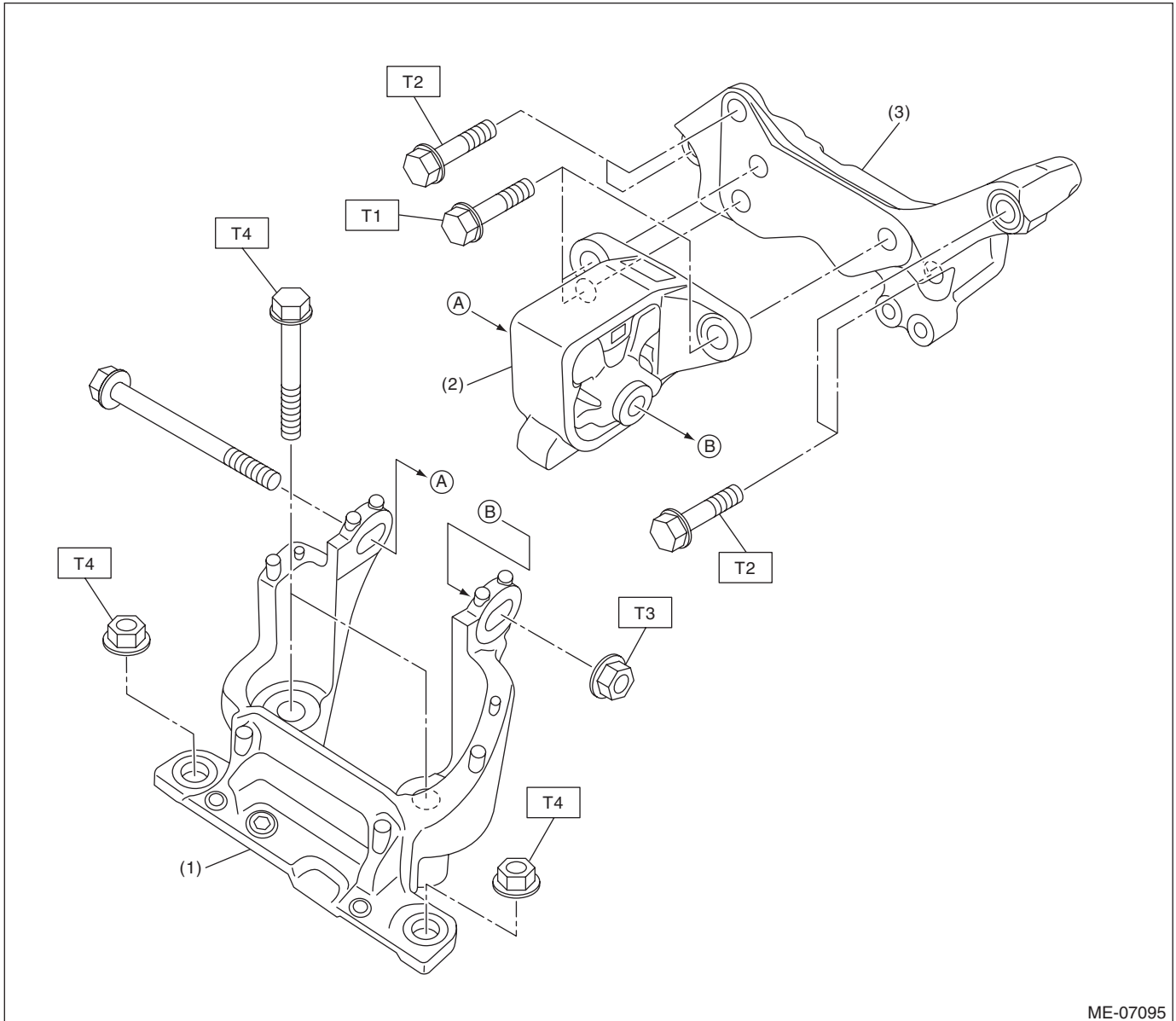

ME-07095

- (1) Front mounting bracket
- (2) Front cushion rubber

- (3) Engine mounting bracket

Tightening torque: N·m (kgf-m, ft-lb)

T1: 25 (2.5, 18.4)

T2: 30 (3.1, 22.1)

T3: 45 (4.6, 33.2)

T4: 60 (6.1, 44.3)

General Description

MECHANICAL

C: CAUTION

- Prior to starting work, pay special attention to the following:
 1. Always wear work clothes, a work cap, and protective shoes. Additionally, wear a helmet, protective goggles, etc. if necessary.
 2. Protect the vehicle using a seat cover, fender cover, etc.
 3. Prepare the service tools, clean cloth, containers to catch grease and oil, etc.
- Vehicle components are extremely hot immediately after driving. Be wary of receiving burns from heated parts.
- When performing a repair, identify the cause of trouble and avoid unnecessary removal, disassembly and replacement.
- Before disconnecting connectors of sensors or units, be sure to disconnect the ground cable from battery.
- Always use the jack-up point when the shop jacks or rigid racks are used to support the vehicle.
- Remove or install the engine in an area where chain hoists, lifting devices, etc. are available for ready use. When lifting up the vehicle, make sure to support the vehicle at the jack-up points.
- Be careful not to let any oil or grease contact the clutch disc or flywheel.
- Remove contamination including dirt and corrosion before removal, installation, disassembly or assembly.
- Keep the removed parts in order and protect them from dust and dirt.
- All removed parts, if to be reused, should be reinstalled in the original positions with attention to the correct directions, etc.
- Rotating parts and sliding parts such as piston, bearing and gear should be coated with oil when being assembled.
- Bolts, nuts and washers should be replaced with new parts as required.
- Be sure to tighten the fasteners including bolts and nuts to the specified torque.

D: PREPARATION TOOL

1. SPECIAL TOOL

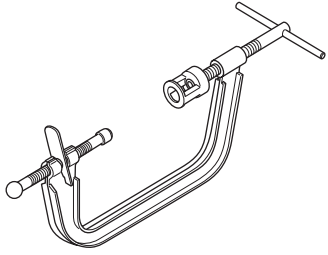
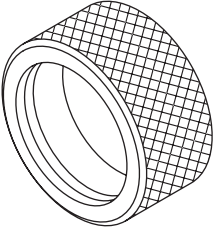
ILLUSTRATION	TOOL NUMBER	DESCRIPTION	REMARKS
 ST0920287002000	0920287002000	REMOVER AND REPLACER	Used for removing and installing valve spring.
 ST-398437700	398437700	OIL SEAL INSTALLER	Used for installing the front oil seal of engine.

General Description

MECHANICAL

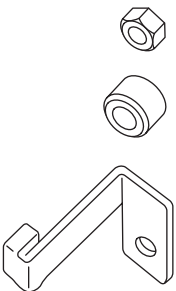
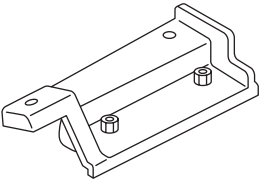
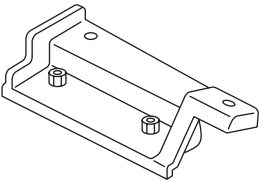
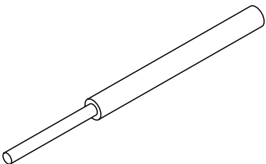
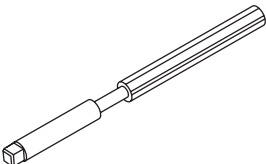
ILLUSTRATION	TOOL NUMBER	DESCRIPTION	REMARKS
 <p>ST-498277200</p>	498277200	STOPPER SET	Used for preventing the torque converter from falling when removing and installing the engine.
 <p>ST-498457000</p>	498457000	ENGINE STAND ADAPTER RH	<ul style="list-style-type: none"> • Used for disassembling and assembling engine. • Used together with ENGINE STAND (499817100) and ADAPTER (18362AA020).
 <p>ST-498457100</p>	498457100	ENGINE STAND ADAPTER LH	<ul style="list-style-type: none"> • Used for disassembling and assembling engine. • Used together with ENGINE STAND (499817100) and ADAPTER (18362AA020).
 <p>ST-499765700</p>	499765700	VALVE GUIDE REMOVER AND INSTALLER	Used for removing and installing valve guide.
 <p>ST-499765900</p>	499765900	VALVE GUIDE REAMER	Used for reaming valve guides.

General Description

MECHANICAL

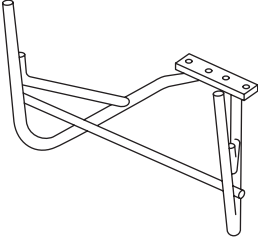
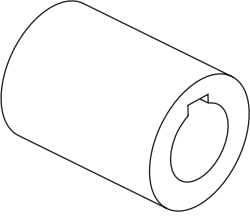
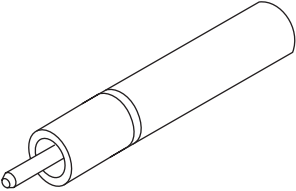
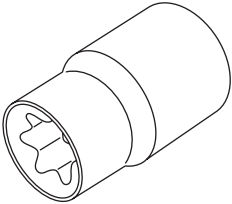
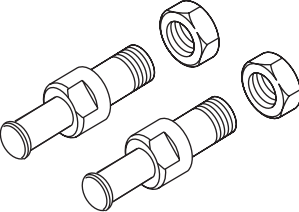
ILLUSTRATION	TOOL NUMBER	DESCRIPTION	REMARKS
 <p style="text-align: center;">ST-499817100</p>	499817100	ENGINE STAND	<ul style="list-style-type: none"> • Used for disassembling and assembling engine. • Used together with ADAPTER (18362AA020), ENGINE STAND ADAPTER RH (498457000) and LH (498457100).
 <p style="text-align: center;">ST18252AA000</p>	18252AA000	CRANKSHAFT SOCKET	Used for rotating crankshaft.
 <p style="text-align: center;">ST18261AA010</p>	18261AA010	VALVE OIL SEAL GUIDE	Used for press-fitting of intake valve guide stem seals and exhaust valve guide stem seals.
 <p style="text-align: center;">ST18270AA020</p>	18270AA020	SOCKET	Used for removing and installing connecting rod.
 <p style="text-align: center;">ST18334AA000</p>	18334AA000	PULLEY WRENCH PIN SET	<ul style="list-style-type: none"> • Used for removing and installing the crank pulley. • Used together with PULLEY WRENCH (18355AA000).

General Description

MECHANICAL

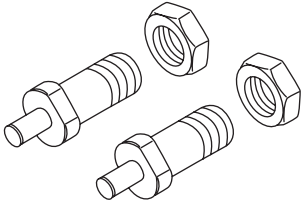
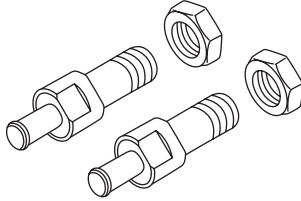
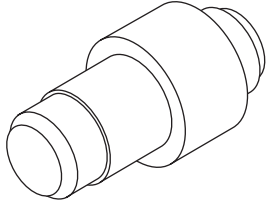
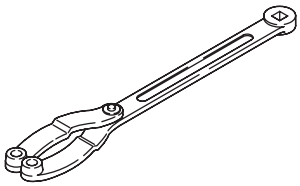
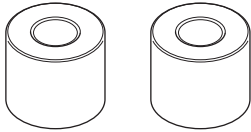
ILLUSTRATION	TOOL NUMBER	DESCRIPTION	REMARKS
 <p>ST18334AA020</p>	18334AA020	PULLEY WRENCH PIN SET	<ul style="list-style-type: none"> • Used for removing and installing exhaust cam sprocket. • Used together with PULLEY WRENCH (18355AA000).
 <p>ST18334AA030</p>	18334AA030	PULLEY WRENCH PIN SET	<ul style="list-style-type: none"> • Used for removing and installing water pump pulley and intake cam sprocket. • Used together with PULLEY WRENCH (18355AA000).
 <p>ST18350AA000</p>	18350AA000	CONNECTING ROD BUSHING REMOVER AND INSTALLER	Used for removing and installing the connecting rod bushing at connecting rod small end.
 <p>ST18355AA000</p>	18355AA000	PULLEY WRENCH	<ul style="list-style-type: none"> • Used for installing and removing the water pump pulley. • Used for removing and installing the crank pulley. • Used for removing and installing intake cam sprocket and exhaust cam sprocket LH. • Used together with PULLEY WRENCH PIN SET (18334AA000), PULLEY WRENCH PIN SET (18334AA020) or PULLEY WRENCH PIN SET (18334AA030).
 <p>ST18362AA020</p>	18362AA020	ADAPTER	<ul style="list-style-type: none"> • Used for disassembling and assembling engine. • Used together with STAND (499817100), ENGINE STAND ADAPTER RH (498457000) and LH (498457100). • Bolt used: M10 × 50 (SUBARU genuine Part No.: 010410500)

General Description

MECHANICAL

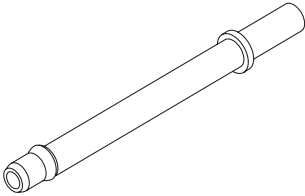
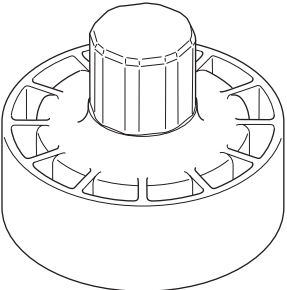
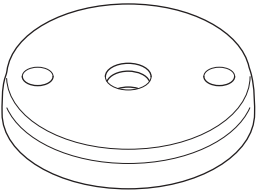
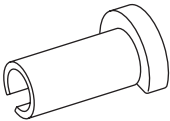
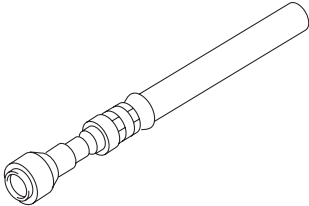
ILLUSTRATION	TOOL NUMBER	DESCRIPTION	REMARKS
 <p style="text-align: center;">ST18471AA000</p>	18471AA000	FUEL PIPE ADAPTER	Used for inspecting the fuel pressure.
 <p style="text-align: center;">ST18657AA030</p>	18657AA030	OIL SEAL INSTALLER	<ul style="list-style-type: none"> • Used for installing the rear oil seal of engine. • Used together with OIL SEAL GUIDE (18671AA020).
 <p style="text-align: center;">ST18671AA020</p>	18671AA020	OIL SEAL GUIDE	<ul style="list-style-type: none"> • Used for installing the rear oil seal of engine. • Used together with OIL SEAL INSTALLER (18657AA030).
 <p style="text-align: center;">ST42099AE000</p>	42099AE000	QUICK CONNECTOR RELEASE	Used for removing the quick connector.
 <p style="text-align: center;">ST42075AG690</p>	42075AG690	FUEL HOSE	Used for inspecting the fuel pressure. NOTE: This is the SUBARU genuine part.

General Description

MECHANICAL

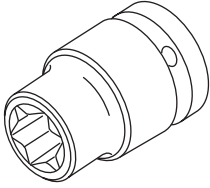
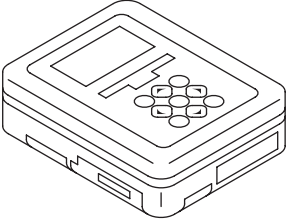
ILLUSTRATION	TOOL NUMBER	DESCRIPTION	REMARKS
 <p>ST18270KA010</p>	18270KA010	SOCKET	Used for installing and removing intake cam sprocket and exhaust cam sprocket.
 <p>ST1B022XU0</p>	1B022XU0	SUBARU SELECT MONITOR III KIT	Used for various inspections.

2. GENERAL TOOL

TOOL NAME	REMARKS
Compression gauge	Used for measuring compression.
Vacuum gauge	Used for measuring intake manifold vacuum.
Oil pressure gauge	Used for measuring engine oil pressure.
Fuel pressure gauge	Used for measuring fuel pressure.
Piston ring compressor	Used for installing the piston into the cylinder block.
Thickness gauge	Used for various inspections.
Angle gauge	Used for angle tightening.