

13.Crank Pulley

A: REMOVAL

NOTE:

When replacing a single part, perform the work with the engine assembly installed to body.

- 1) Remove the V-belts. <Ref. to ME(H4DO)-80, REMOVAL, V-belt.>
- 2) Use the ST to lock the crank pulley, and remove the crank pulley bolt.

NOTE:

To prevent damaging ST1, attach the ST2 onto the ST1 as shown.

- ST1 18355AA000 PULLEY WRENCH
ST2 18334AA000 PULLEY WRENCH PIN SET

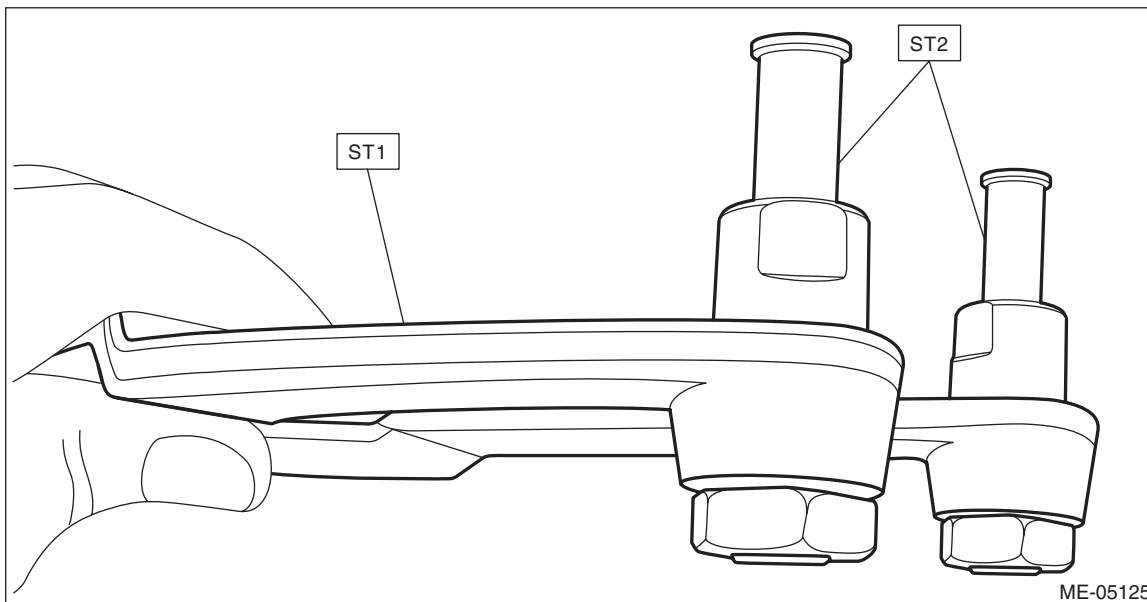

Crank Pulley

MECHANICAL

ST1 18355AA000 PULLEY WRENCH
ST2 18334AA000 PULLEY WRENCH PIN SET

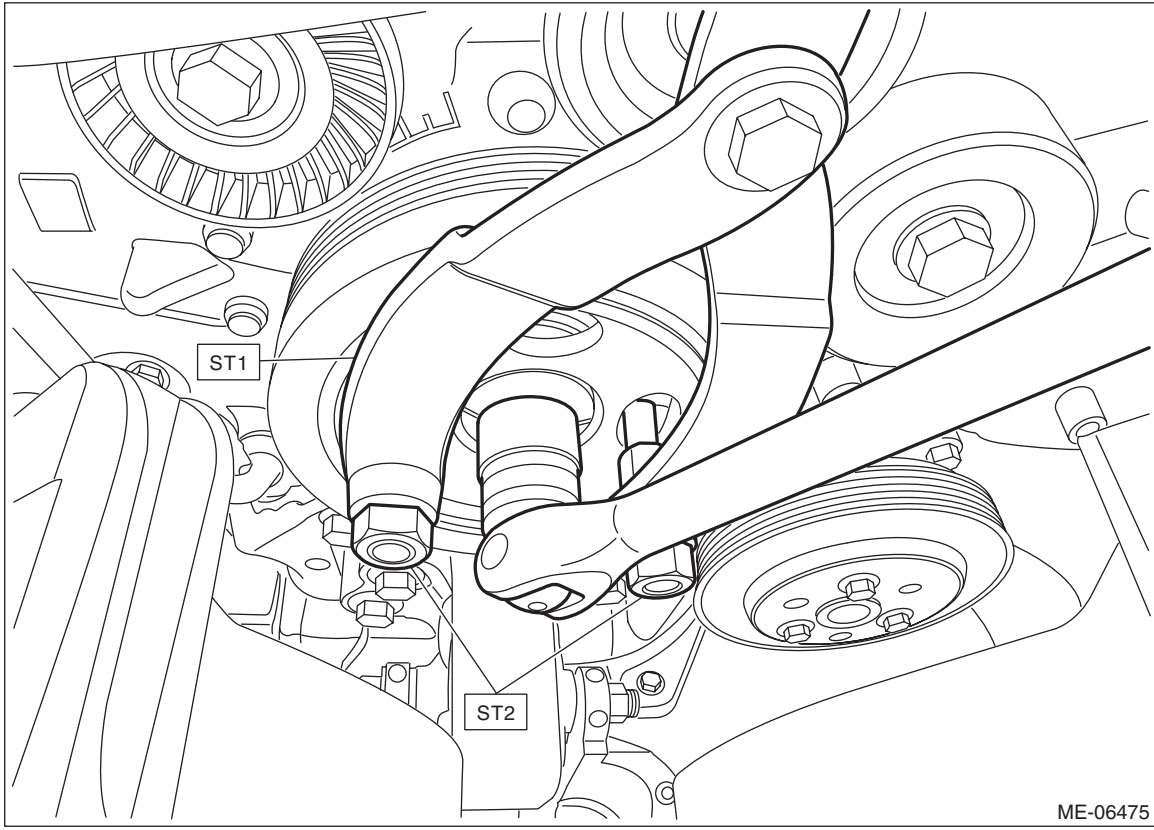

ME-06475

3) Remove the crank pulley.

B: INSTALLATION

- 1) Clean the crankshaft thread using compressed air.
- 2) Apply engine oil to the crank pulley bolt seat and thread.
- 3) Install the crank pulley.

(1) Install the crank pulley to the crank pulley boss.

NOTE:

- Use new O-rings.
- Install the crank pulley by aligning the crank pulley knock hole (A) and crank pulley boss knock pin (B).

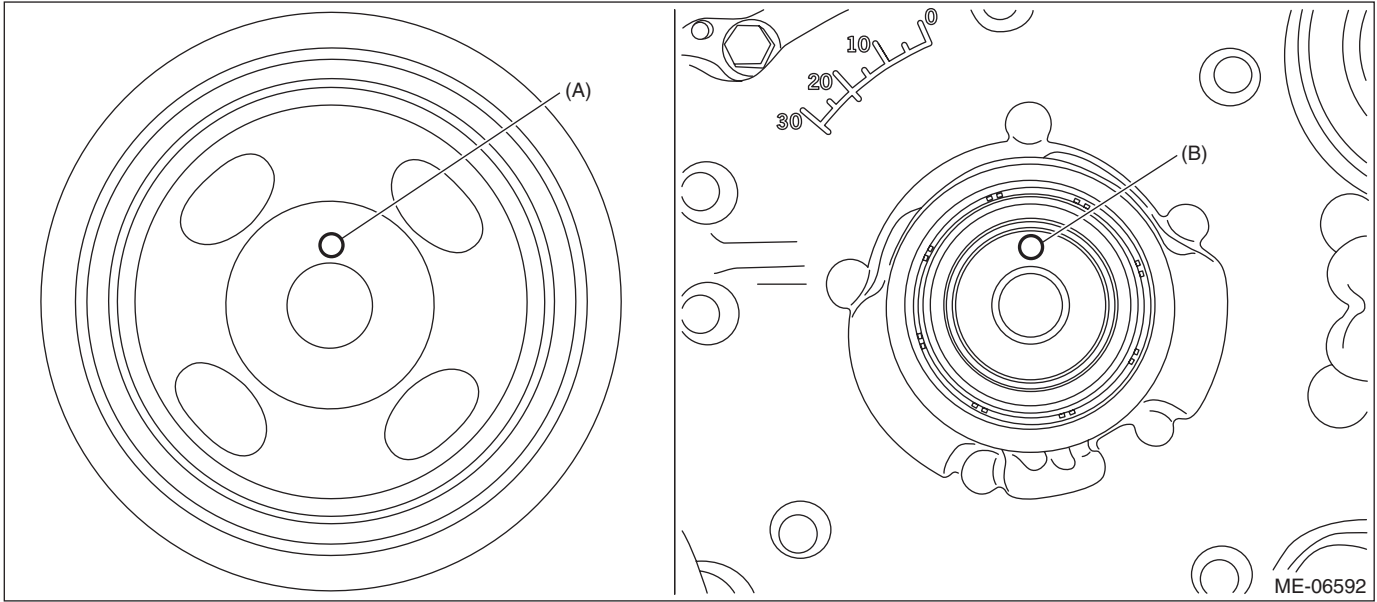

(2) Use the ST to lock the crank pulley, and temporarily tighten the crank pulley bolt.

NOTE:

To prevent damaging ST1, attach the ST2 onto the ST1 as shown.

- ST1 18355AA000 PULLEY WRENCH
 ST2 18334AA000 PULLEY WRENCH PIN SET

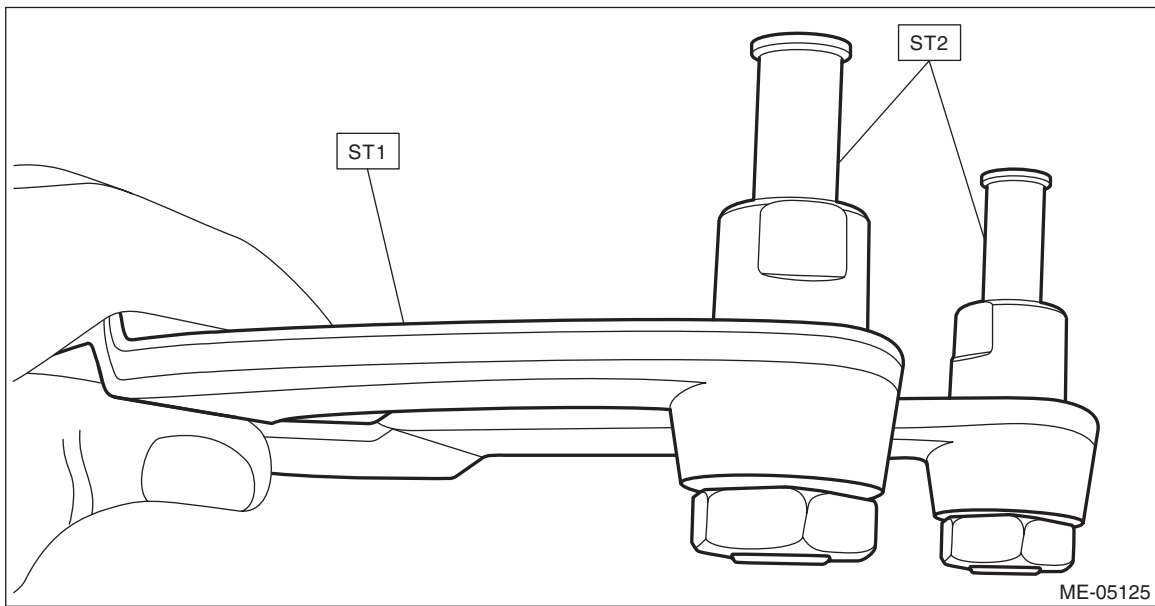

Crank Pulley

MECHANICAL

ST1 18355AA000 PULLEY WRENCH
ST2 18334AA000 PULLEY WRENCH PIN SET

Tightening torque:
60 N·m (6.1 kgf·m, 44.3 ft·lb)

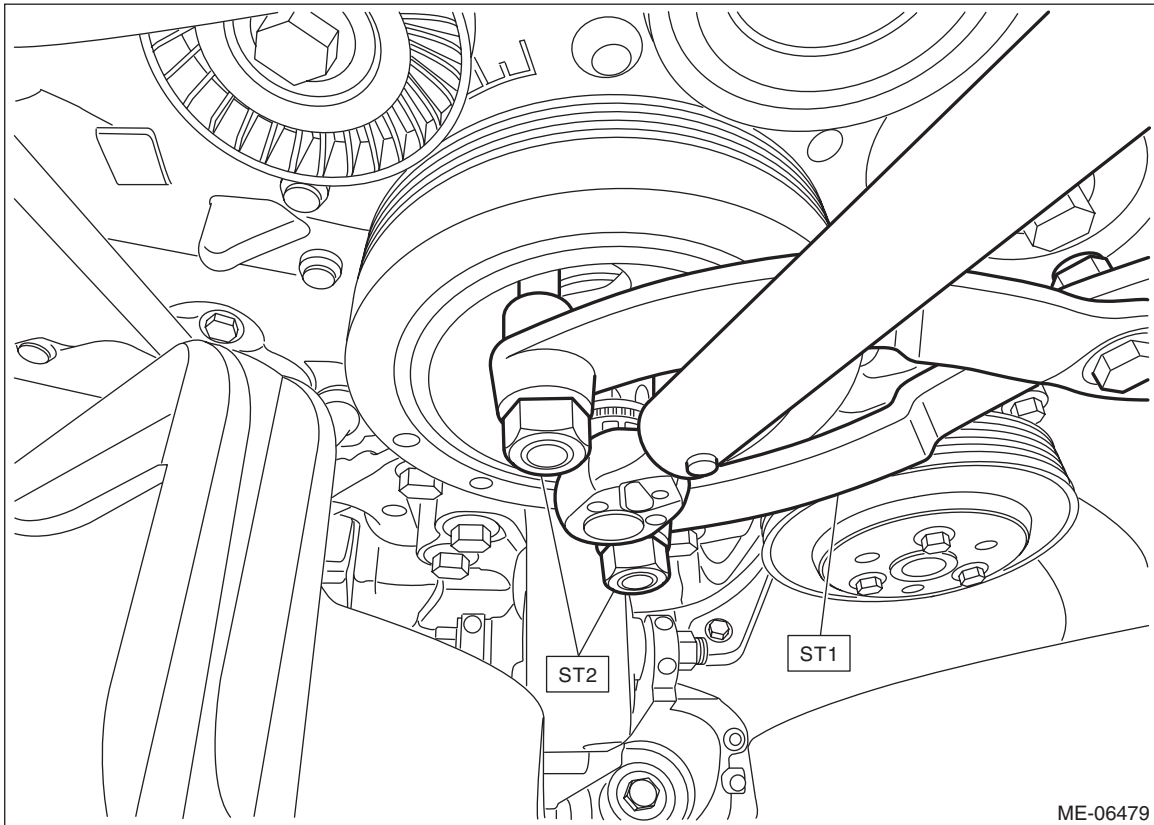

Crank Pulley

(3) Draw reference lines (A) and (B) using a marker to set the socket to the crank pulley bolt as shown in the figure.

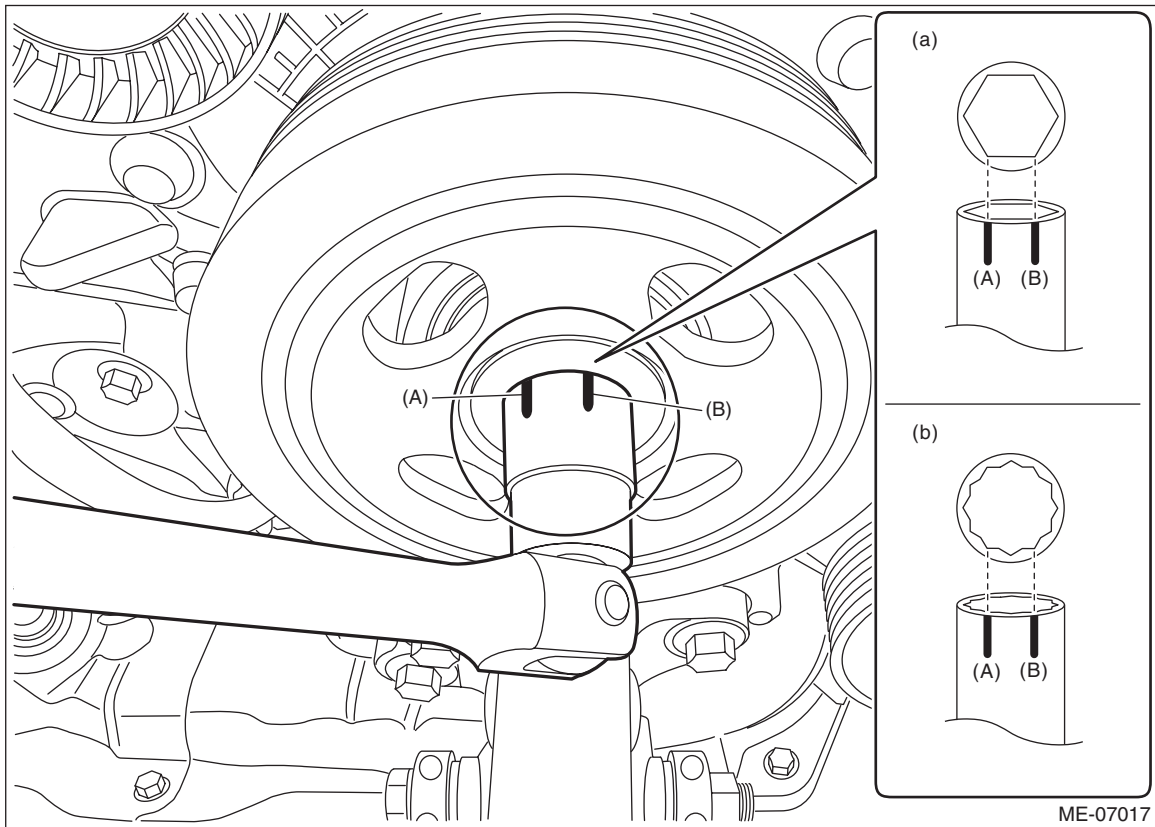

(a) When using 6-point socket

(b) When using 12-point socket

Crank Pulley

MECHANICAL

(4) Draw reference lines (A) and (B) on the crank pulley bolt using a marker as shown in the figure.

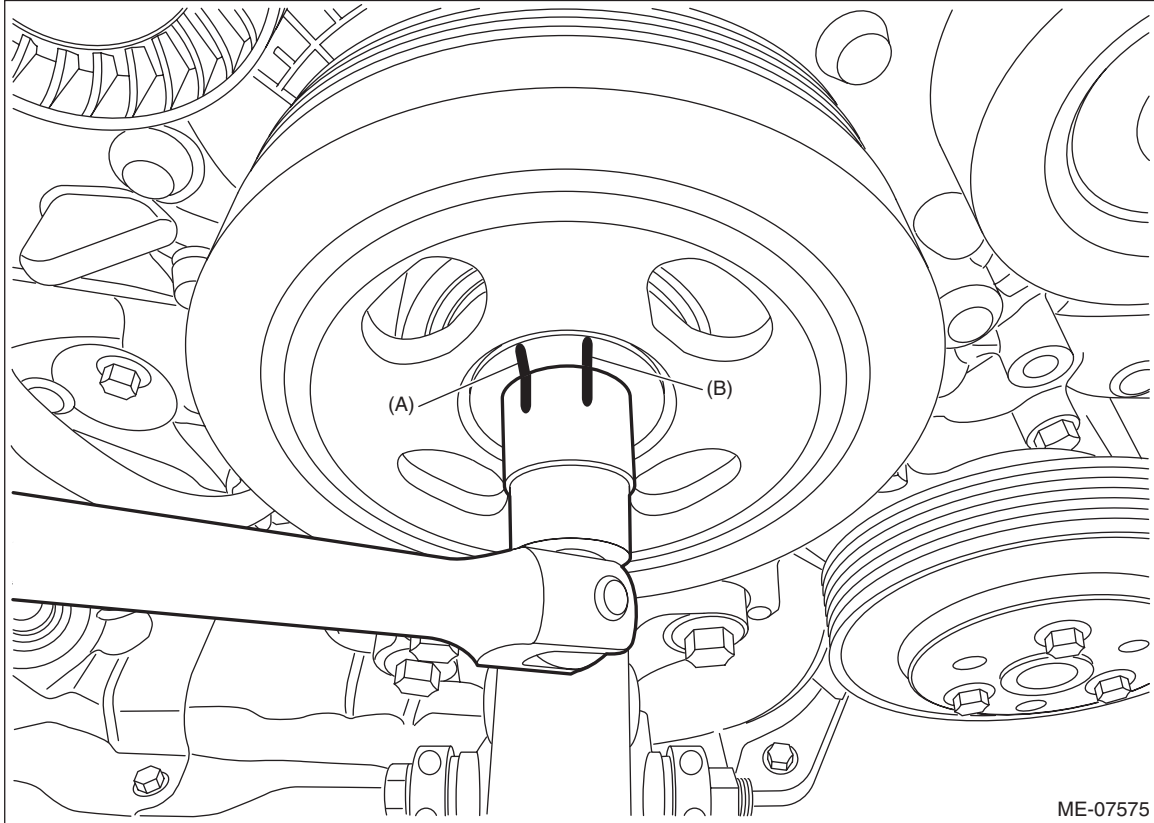

(5) Draw end line (C) on crank pulley using a marker at the same position as reference line (B) drawn on the crank pulley bolt in step (4).

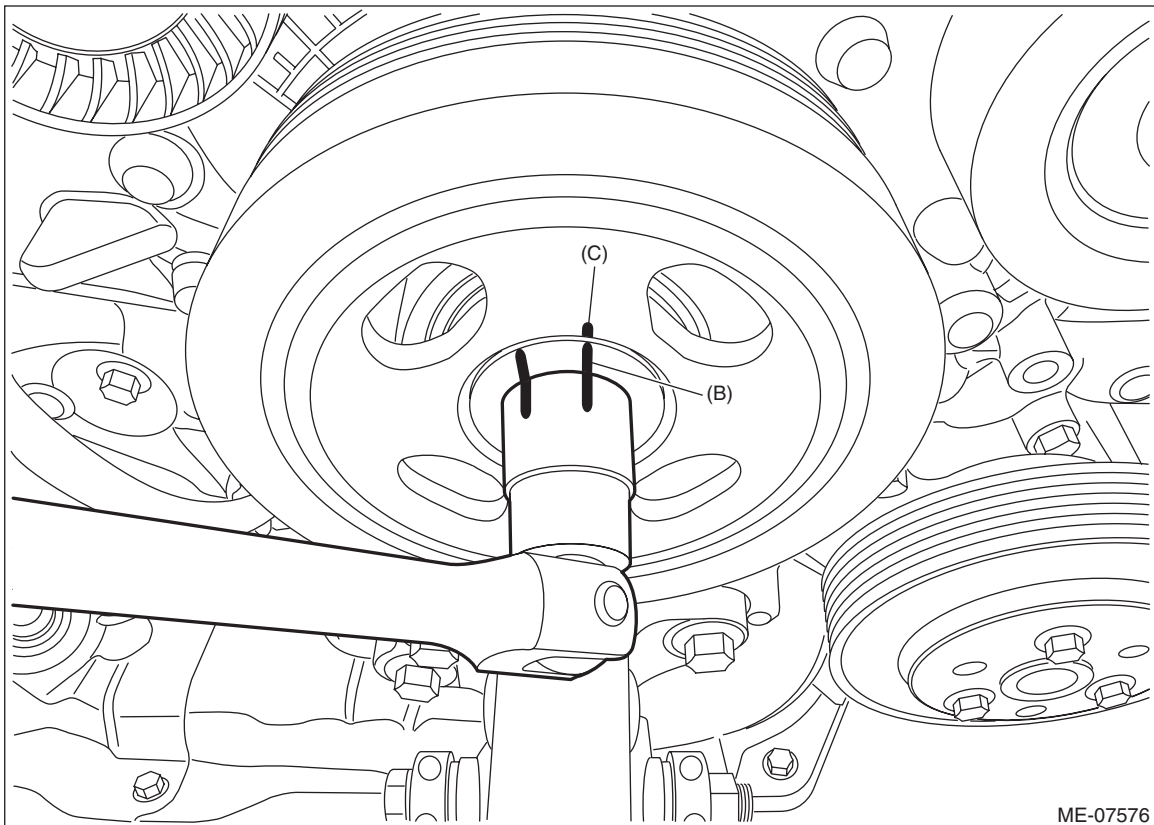

Crank Pulley

MECHANICAL

- (6) Use the ST to lock the crank pulley, and tighten the crank pulley bolt to the angle where reference line (A) and end line (C) are aligned.

NOTE:

It should be approx. 60° when reference line (A) and end line (C) are aligned.

ST1 18355AA000 PULLEY WRENCH

ST2 18334AA000 PULLEY WRENCH PIN SET

Tightening angle:

$60^{\circ} \pm 5^{\circ}$

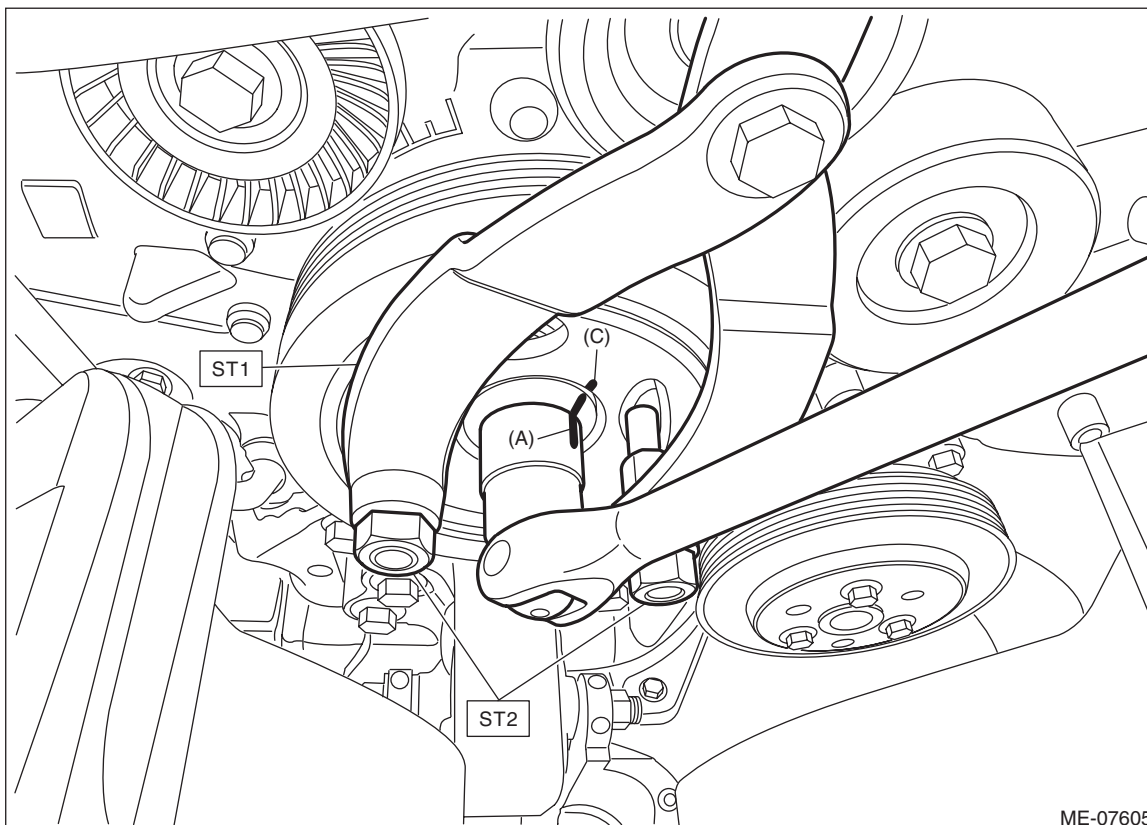

- 4) Install the V-belts. <Ref. to ME(H4DO)-82, INSTALLATION, V-belt.>

Crank Pulley

MECHANICAL

C: INSPECTION

1) Check that the crank pulley and crank pulley boss have no deformation, cracks or other damages.
2) Inspect for oil leakage from the front oil seal. If there is an oil leak, replace the front oil seal with a new part according to the following procedures.

- (1) Remove the crank pulley. <Ref. to ME(H4DO)-87, REMOVAL, Crank Pulley.>
- (2) Remove the crank pulley boss from the chain cover.

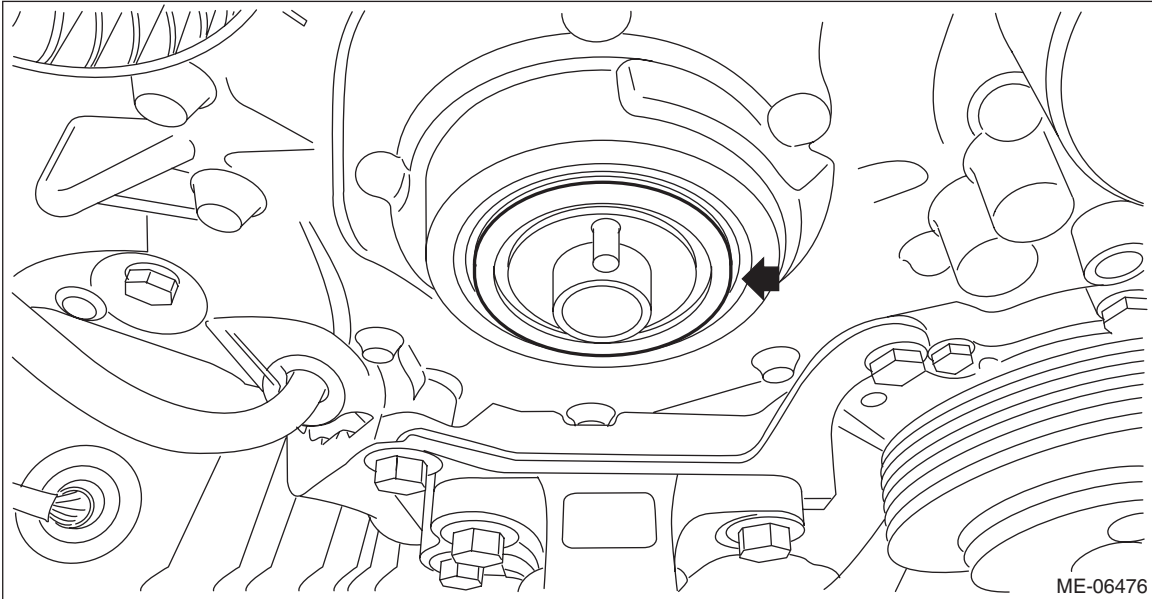

- (3) Remove the front oil seal from the chain cover.

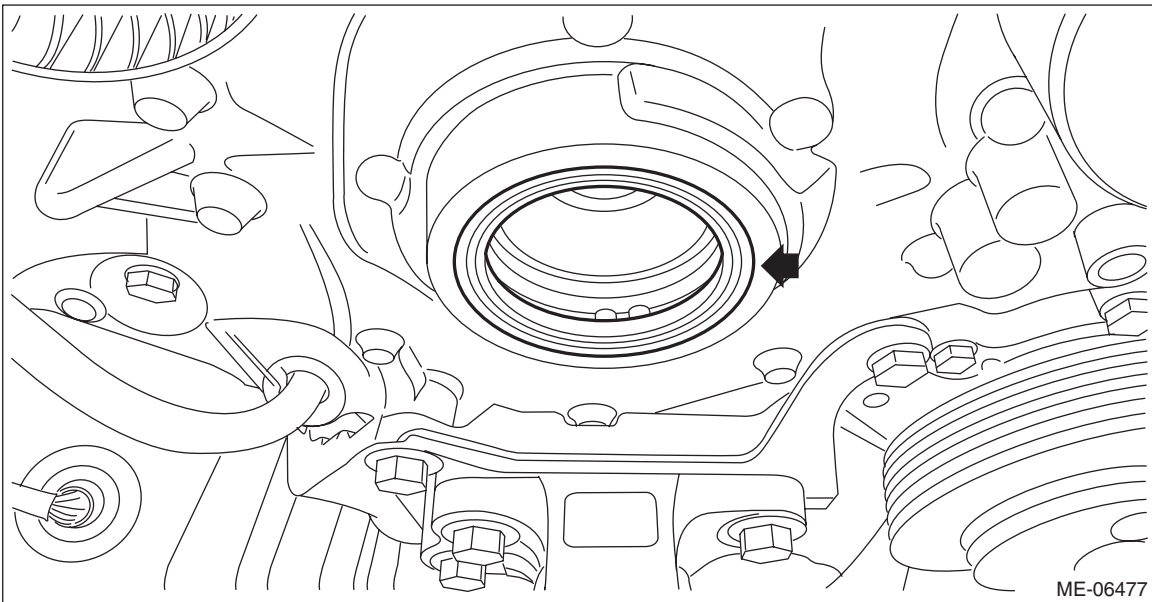

(4) Apply a light coat of engine oil to the front oil seal inner periphery and outer periphery, and install the front oil seal to the chain cover using ST.

NOTE:

When tapping the front oil seal in, protect the radiator fin with cardboards etc. so as not to damage the radiator fin by the plastic hammer.

ST 398437700 OIL SEAL INSTALLER

Front oil seal press-fit position:

1^{+0}_{-1} mm ($0.0039^{+0}_{-0.0039}$ in) position from chain cover end face

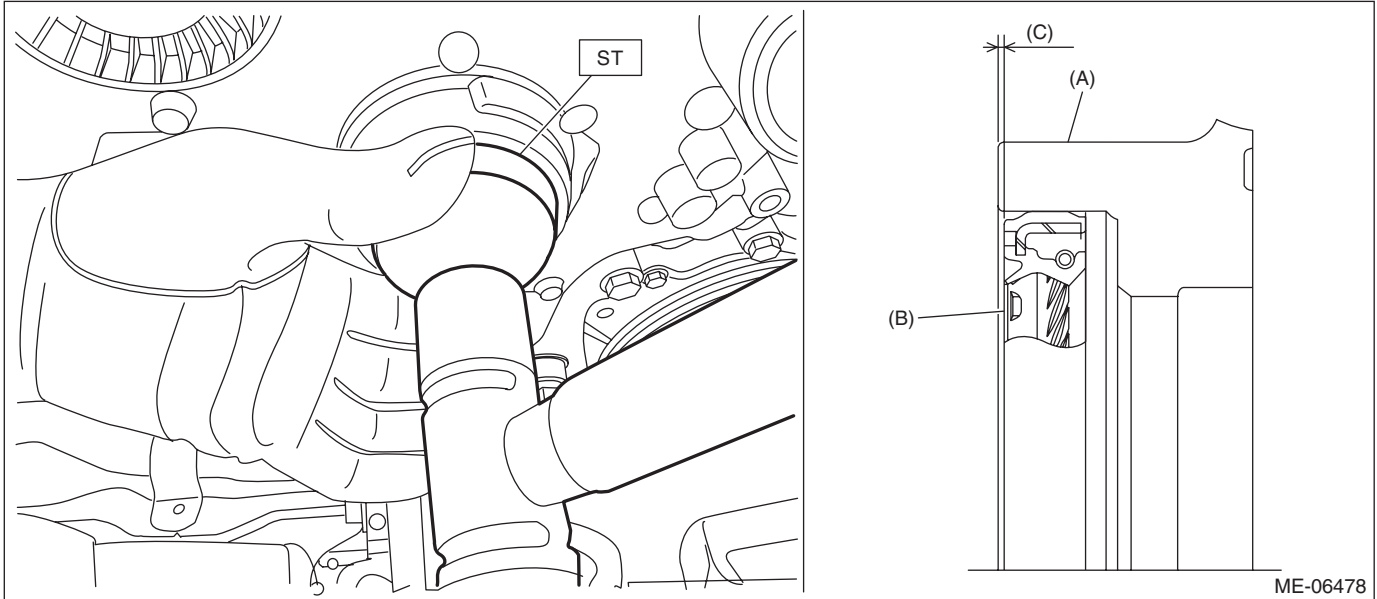

(A) Chain cover

(B) Oil seal

(C) Front oil seal press-fit position (1^{+0}_{-1} mm ($0.0039^{+0}_{-0.0039}$ in) position from chain cover end face)

3) Install in the reverse order of removal after replacement.