

15. Timing Chain Assembly

A: REMOVAL

1. TIMING CHAIN RH

NOTE:

When replacing a single part, perform the work with the engine assembly installed to body.

1) Remove the chain cover. <Ref. to ME(H4DO)-96, REMOVAL, Chain Cover.>

2) Using ST and by turning the crankshaft, align the alignment marks of crank sprocket, intake cam sprocket RH and exhaust cam sprocket RH to the positions as shown in the figure.

NOTE:

If the alignment marks are aligned to the positions as shown in the figure, the crankshaft key is located at six o'clock position.

ST 18252AA000 CRANKSHAFT SOCKET

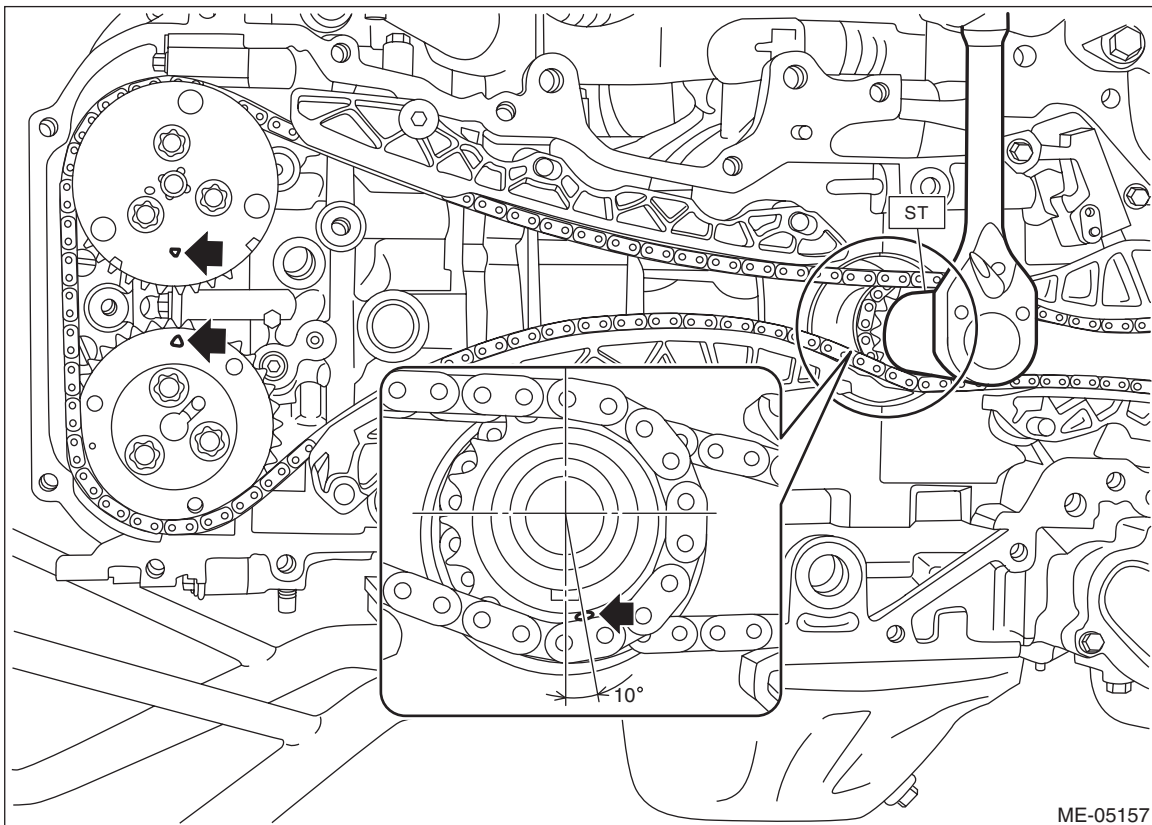

ME-05157

Timing Chain Assembly

MECHANICAL

- 3) Push down the chain lever tensioner RH, and with a 2.5 mm (0.98 in) dia. stopper pin or a 2.5 mm (0.98 in) dia. hex wrench inserted into the stopper pin hole in the chain tensioner RH, secure the plunger (A).

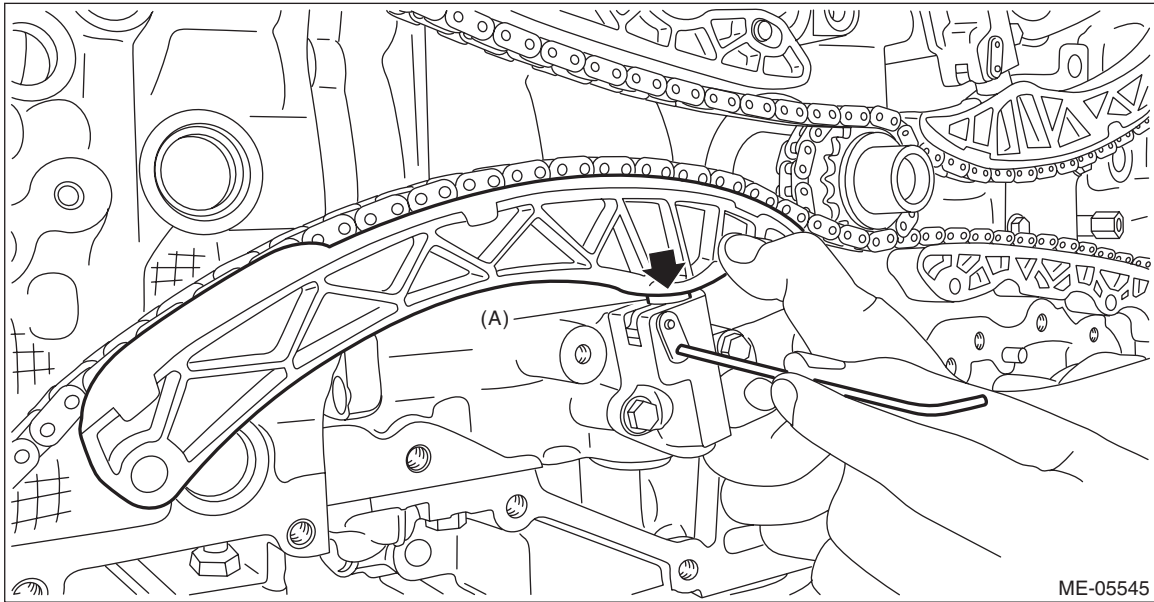

- 4) Remove the chain tensioner RH, and remove the chain tensioner lever RH (A).

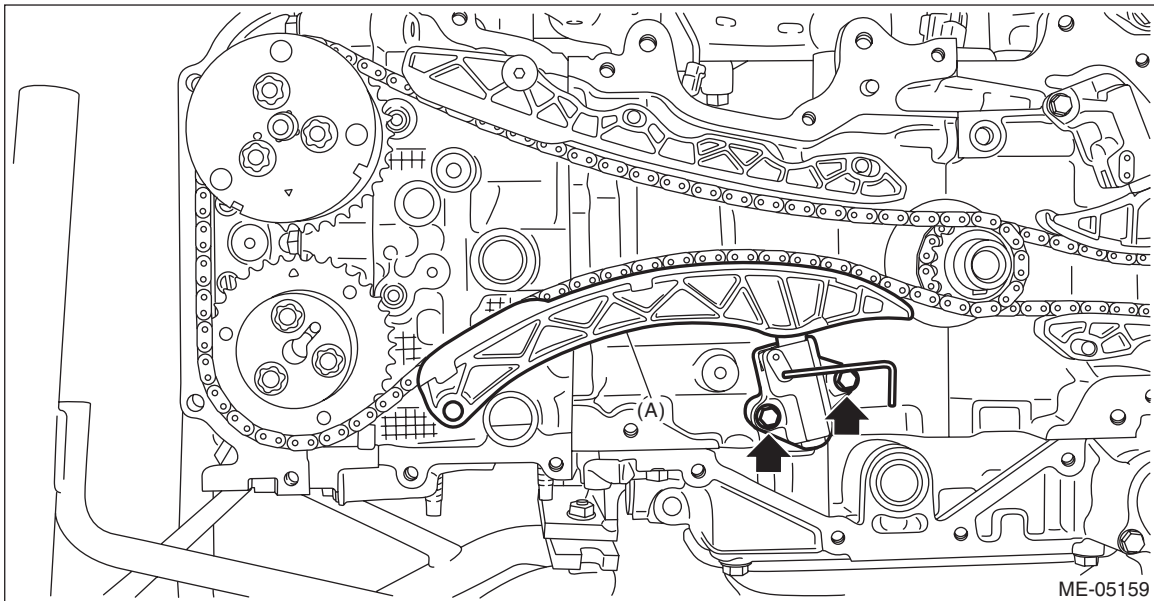

Timing Chain Assembly

MECHANICAL

5) Remove the chain guide RH, and remove the timing chain RH (A).

CAUTION:

- If the timing chain RH is not installed, the intake camshaft RH and exhaust camshaft RH are kept at zero-lift position. All cams on the camshaft are not pressing down the roller rocker arm (intake valve and exhaust valve). (Under this condition, all valves remain unlifted.)
- Intake camshaft RH and exhaust camshaft RH can be independently rotated with the timing chain RH removed. When the intake valve and exhaust valve lift at the same time, the valve heads contact each other and valve stem may bend. Do not turn it to the outside of range of zero-lift (in range where it can be turned lightly by hand).

NOTE:

To avoid mixing with LH side, keep the removed part in order.

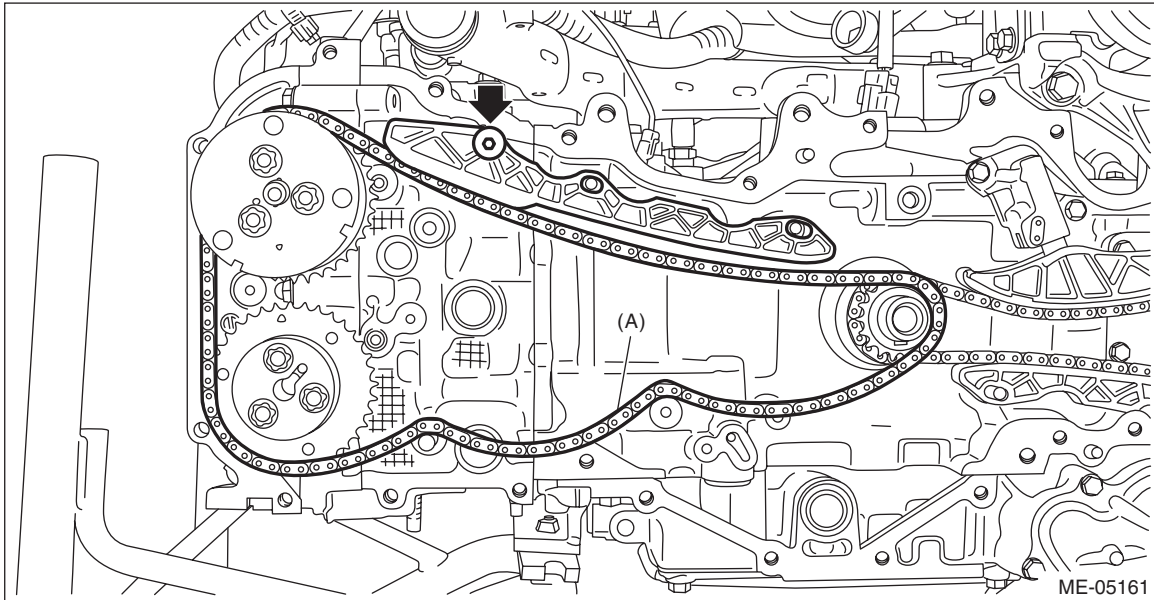

Timing Chain Assembly

MECHANICAL

2. TIMING CHAIN LH

1) Remove the timing chain RH. <Ref. to ME(H4DO)-111, TIMING CHAIN RH, REMOVAL, Timing Chain Assembly.>

2) Using ST and by turning the crankshaft, align the alignment marks of crankshaft key, intake cam sprocket LH and exhaust cam sprocket LH to the positions as shown in the figure.

ST 18252AA000 CRANKSHAFT SOCKET

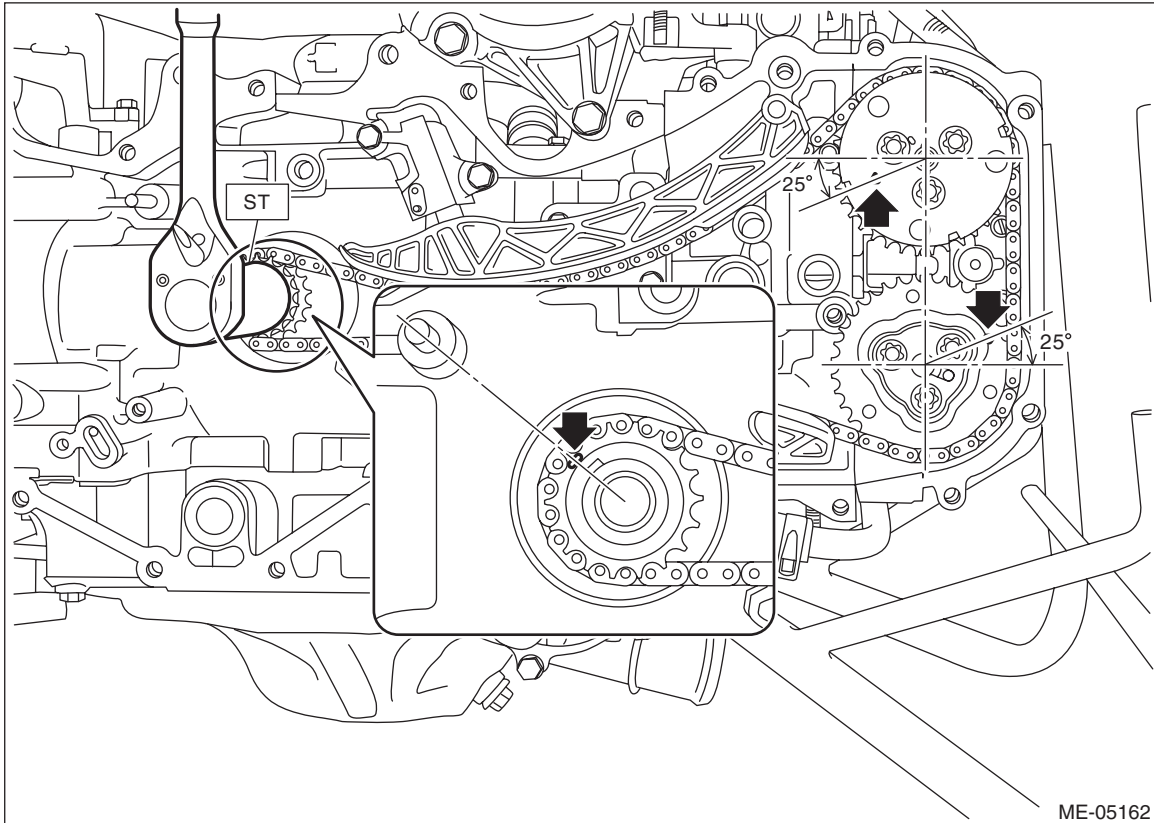

ME-05162

3) Push down the chain lever tensioner LH, and with a 2.5 mm (0.98 in) dia. stopper pin or a 2.5 mm (0.98 in) dia. hex wrench inserted into the stopper pin hole in the chain tensioner LH, secure the plunger (A).

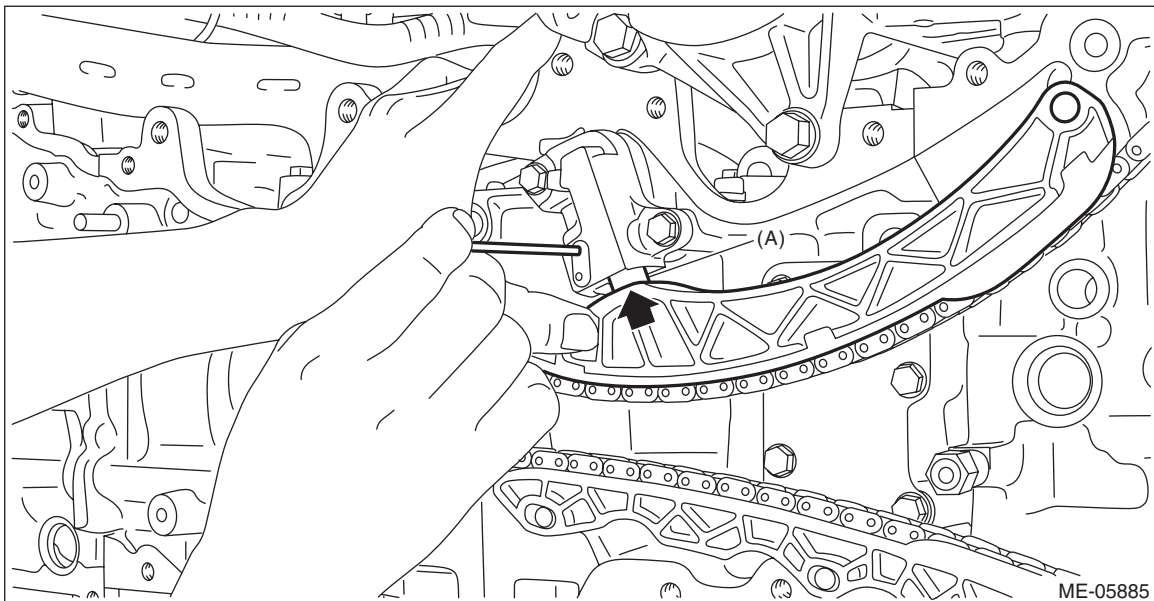

ME-05885

- 4) Remove the chain tensioner LH, and remove the chain tensioner lever LH (A).

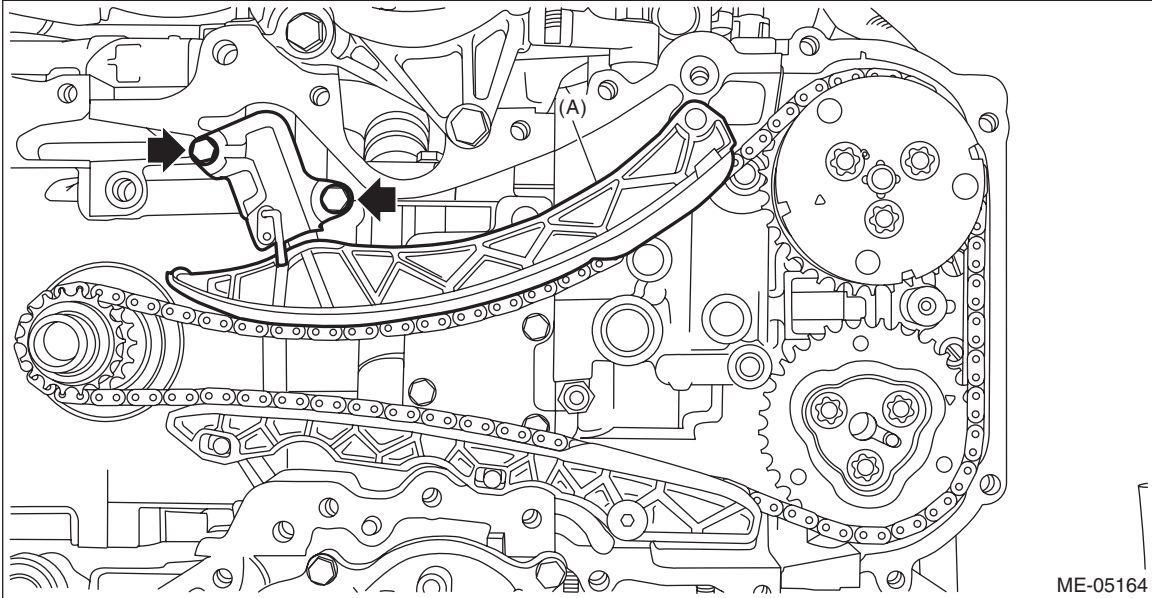

- 5) Remove the O-ring from the cylinder block LH.

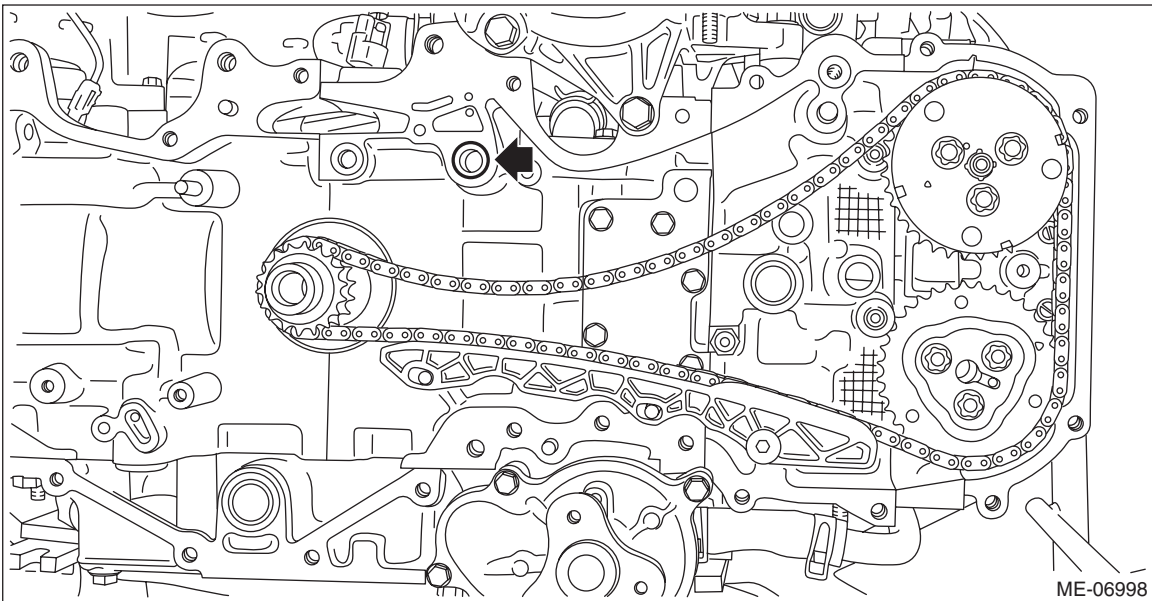

- 6) Remove the chain guide LH, and remove the timing chain LH (A).

CAUTION:

- If the timing chain LH is not installed, the exhaust camshaft LH is kept at zero-lift position. All cams on the exhaust camshaft LH are not pressing down the roller rocker arm (exhaust valve). (Under this condition, exhaust valves remain unlifted.)
- Intake camshaft LH is kept at lift position. All cams on the intake camshaft LH are pressing down the roller rocker arm (intake valve). (Under this condition, intake valves remain lifted.)
- Intake camshaft LH and exhaust camshaft RH can be independently rotated with the timing chain LH removed. When the exhaust camshaft LH is turned, the valve heads contact each other and valve stem may bend as described in above. Do not turn the exhaust camshaft LH to the outside of range of zero-lift (in range where it can be turned lightly by hand).
- #1 piston and #4 piston are located near TDC. If the intake camshaft LH is turned, the valve and the piston may contact and valve stem may bend. Do not turn the intake camshaft LH at this time.

Timing Chain Assembly

MECHANICAL

NOTE:

To avoid mixing with RH side, keep the removed part in order.

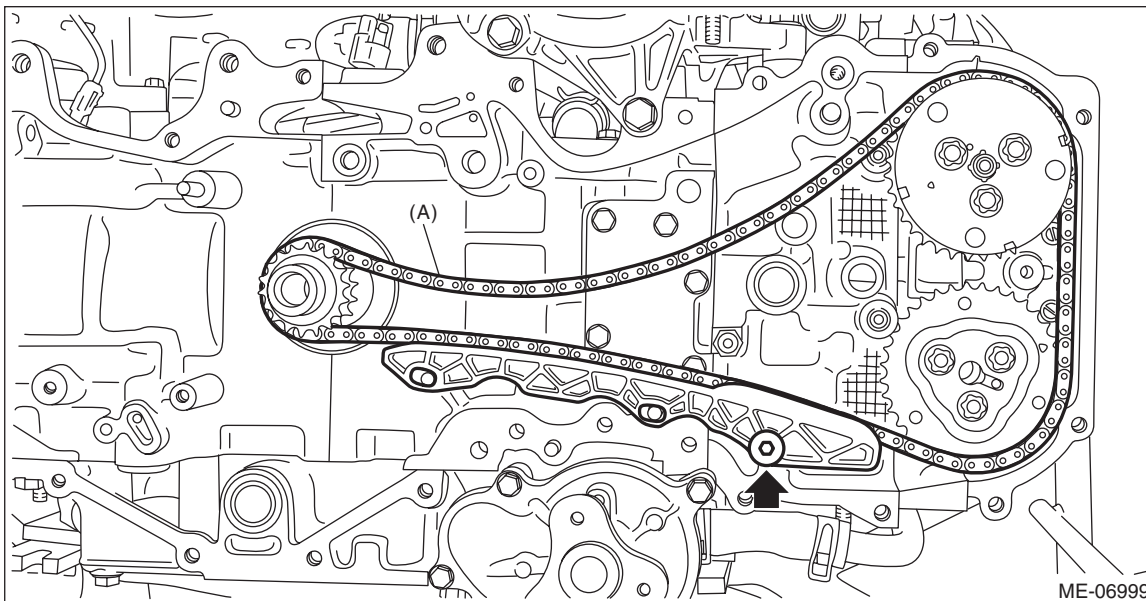

7) Using ST and by turning the crankshaft approximately 200° clockwise, align the alignment marks of crank sprocket to the positions as shown in the figure.

CAUTION:

- This procedure is required to prevent the valve and piston contacting with each other, by moving the all pistons to the middle of the cylinders.
- Never turn counterclockwise because the valve and piston may contact. Counterclockwise turn is allowed only when adjusting precisely the alignment marks, after turning the crank sprocket alignment mark clockwise near the position as shown in the figure.

ST 18252AA000 CRANKSHAFT SOCKET

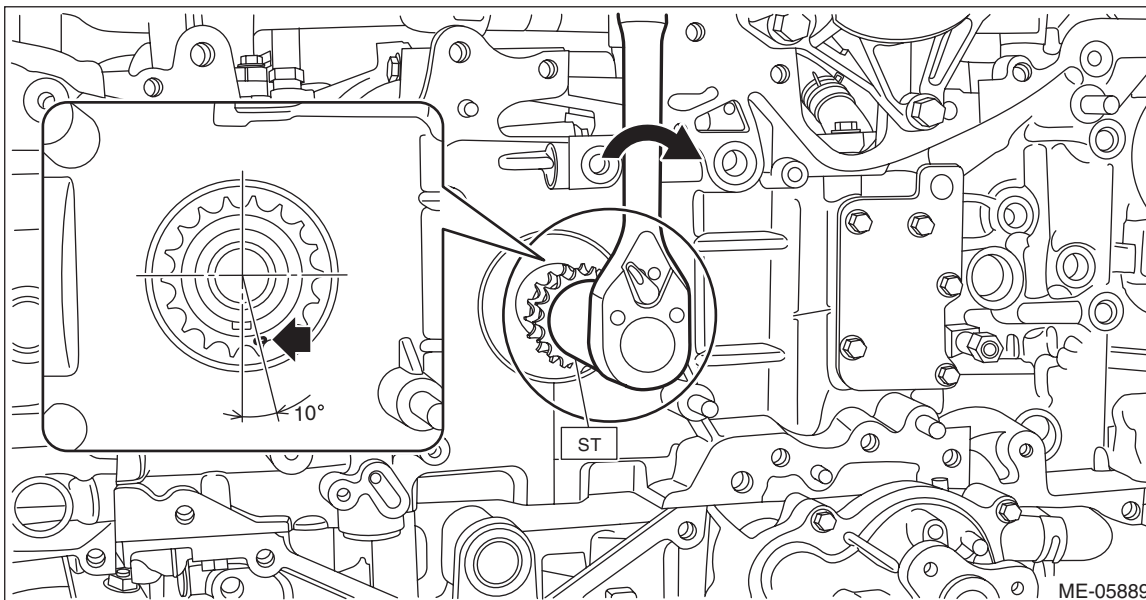

Timing Chain Assembly

MECHANICAL

8) Using ST and by turning the intake cam sprocket LH approximately 180°, align the alignment marks of intake cam sprocket LH to the positions (zero-lift position) as shown in the figure.

CAUTION:

After this work, when the intake valve and exhaust valve lift at the same time, the valve heads contact each other and valve stem may bend. Do not turn the intake camshaft LH and exhaust camshaft LH to the outside of range of zero-lift (in range where it can be turned lightly by hand).

ST1 18355AA000 PULLEY WRENCH

ST2 18334AA030 PULLEY WRENCH PIN SET

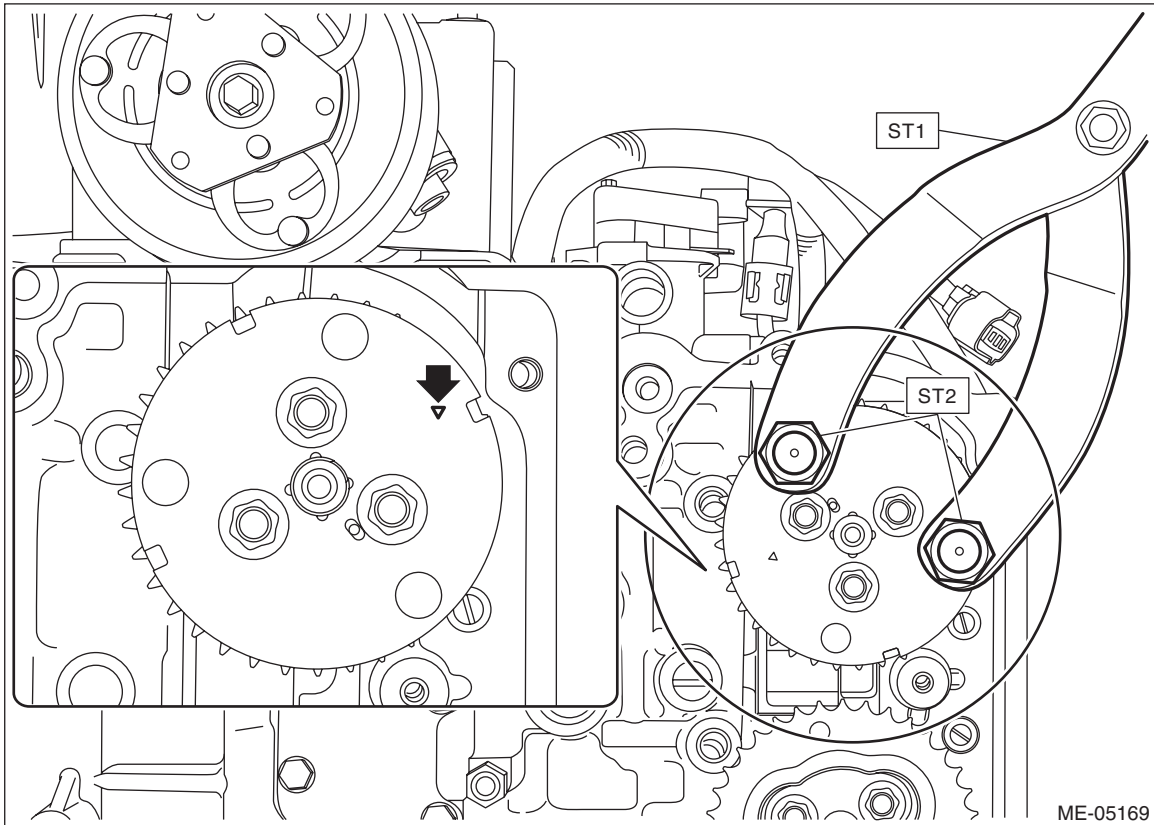

Timing Chain Assembly

MECHANICAL

B: INSTALLATION

1. TIMING CHAIN LH

NOTE:

- Be careful that the foreign matter is not into or onto the assembled component during installation.
- Apply engine oil to all component parts of the timing chain.

1) Prepare to attach the chain tensioner LH.

(1) Move the link plate (A) in the direction of arrow to press in the plunger (B).

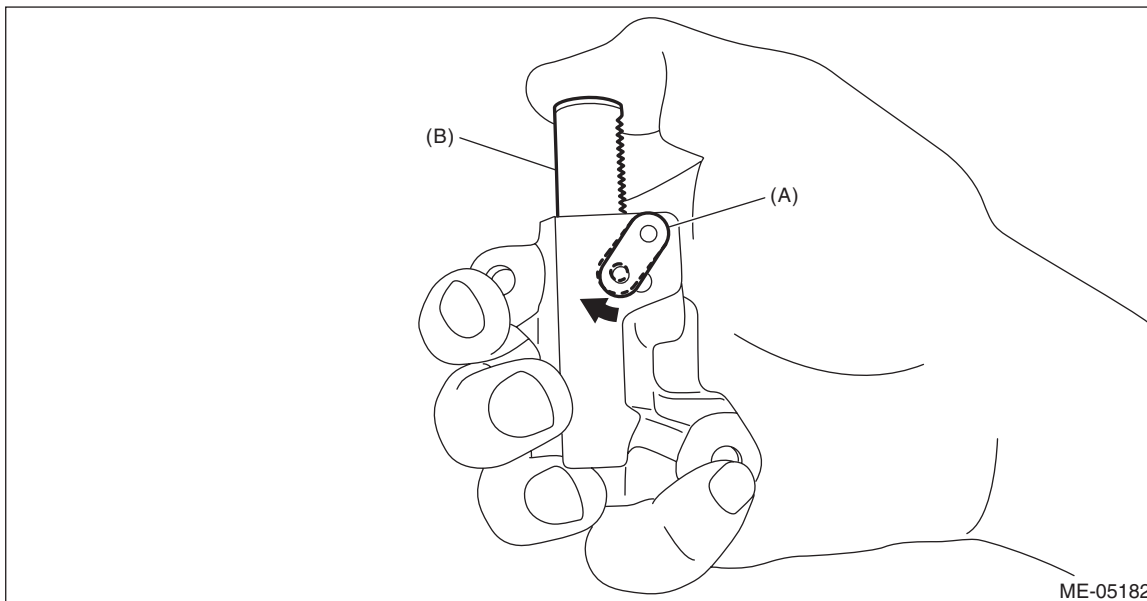

(2) With a 2.5 mm (0.98 in) dia. stopper pin or a 2.5 mm (0.98 in) (nominal) dia. hex wrench inserted into the stopper pin hole, secure the plunger.

NOTE:

If the stopper pin hole on the link plate and the stopper pin hole on the chain tensioner are not aligned, check that the first notch of plunger rack (A) is engaged with the stopper tooth (B). If not engaged, retract the plunger a little so that the first notch of plunger rack (A) is engaged with the stopper tooth (B).

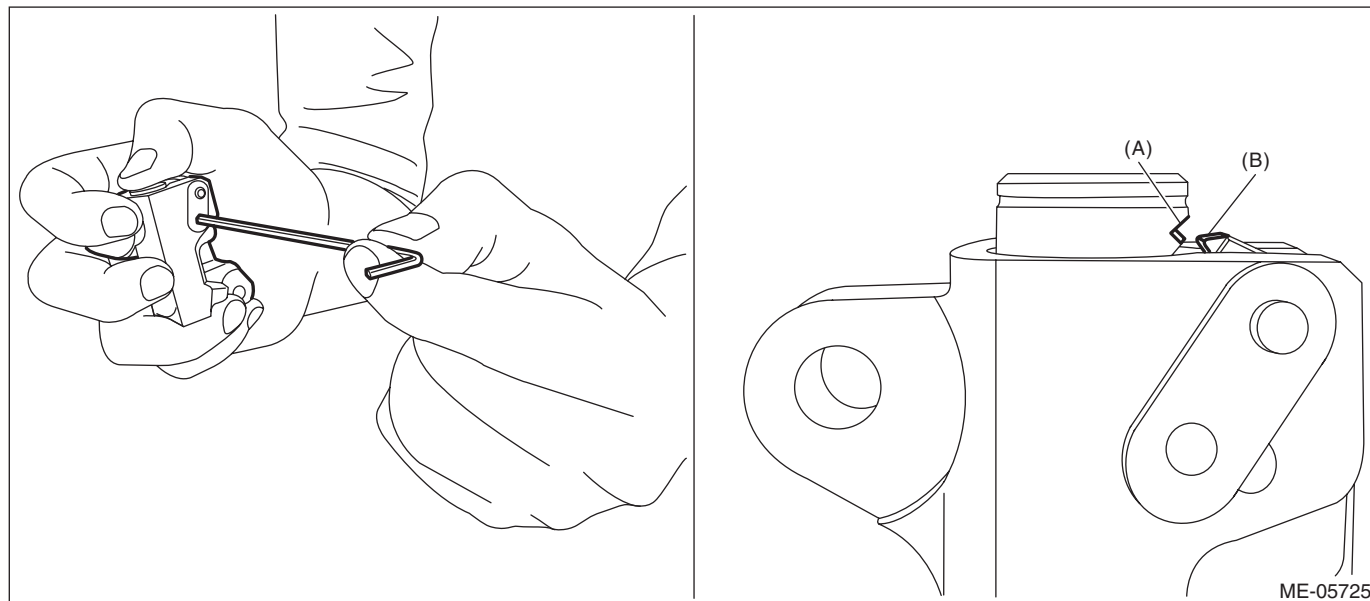

Timing Chain Assembly

MECHANICAL

2) Check that the crank sprocket is located at the position shown in the figure. If not aligned, using ST turn the crankshaft to align the crank sprocket alignment mark to the position shown in the figure.

NOTE:

This procedure is required to prevent the valve and piston contacting with each other in the next step.

ST 18252AA000 CRANKSHAFT SOCKET

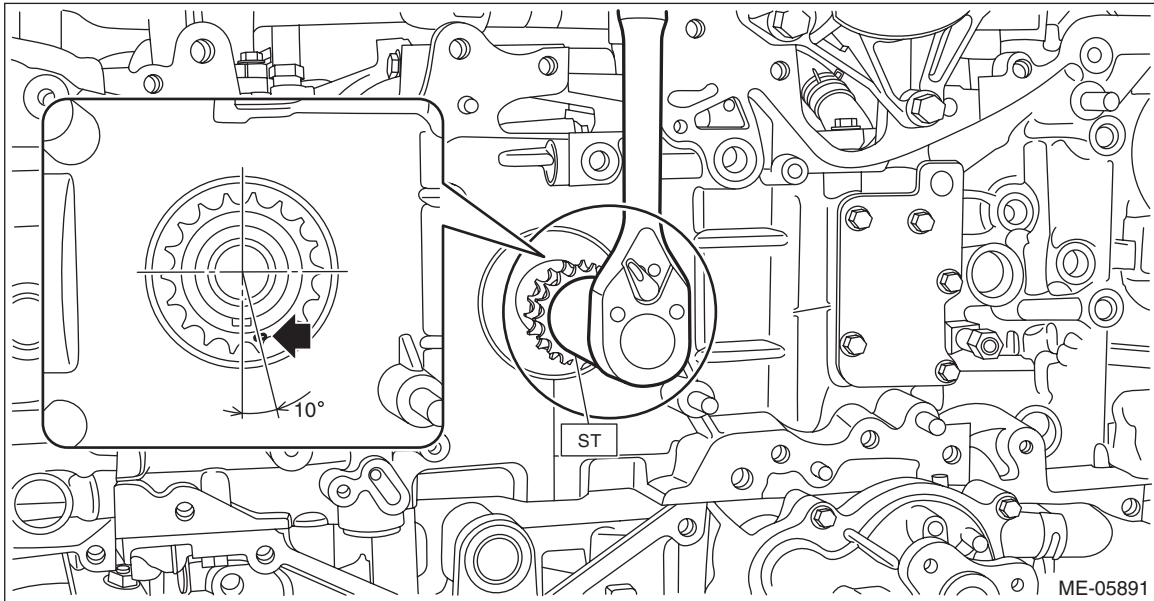

Timing Chain Assembly

MECHANICAL

3) Using ST and by turning the intake cam sprocket LH, align the alignment marks to the positions as shown in the figure.

CAUTION:

When the intake valve and exhaust valve lift at the same time, the valve heads contact each other and valve stem may bend. Do not turn the exhaust camshaft LH.

ST1 18355AA000 PULLEY WRENCH

ST2 18334AA030 PULLEY WRENCH PIN SET

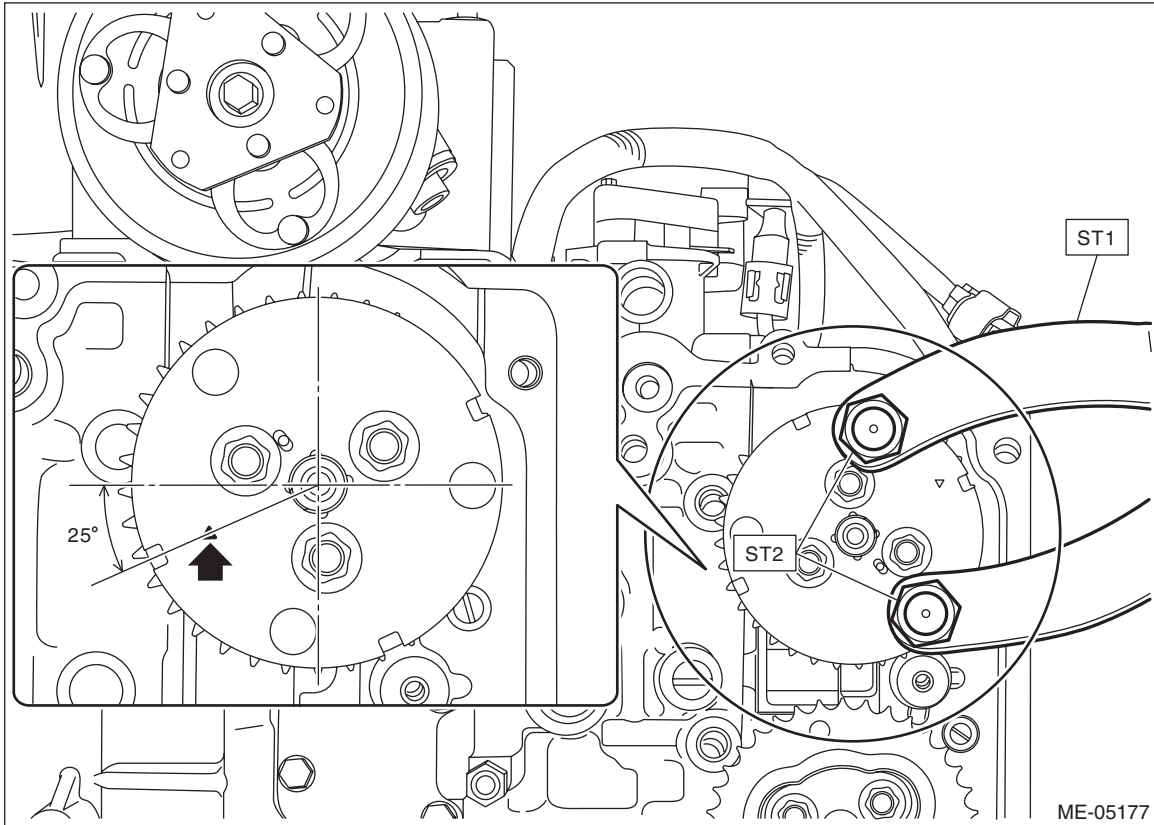

Timing Chain Assembly

MECHANICAL

4) Using ST and by turning the crankshaft approximately 200° counterclockwise, align the alignment marks of crankshaft key to the positions as shown in the figure.

CAUTION:

Never turn clockwise because the valve and piston may contact. Clockwise turn is allowed only when adjusting the key position precisely, after turning the crankshaft counterclockwise to bring the key near the position as shown in the figure.

ST 18252AA000 CRANKSHAFT SOCKET

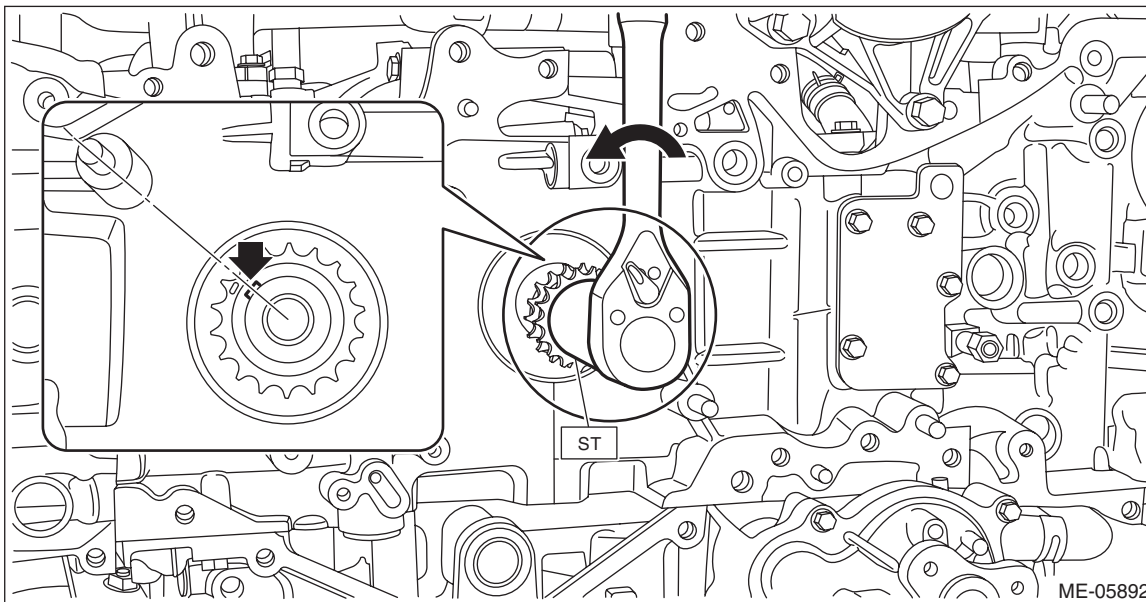

5) Align the alignment mark of exhaust cam sprocket LH to the position shown in the figure.

CAUTION:

To prevent valve damage, turn the exhaust cam sprocket LH only within the range of zero-lift (in range where it can be turned lightly by hand).

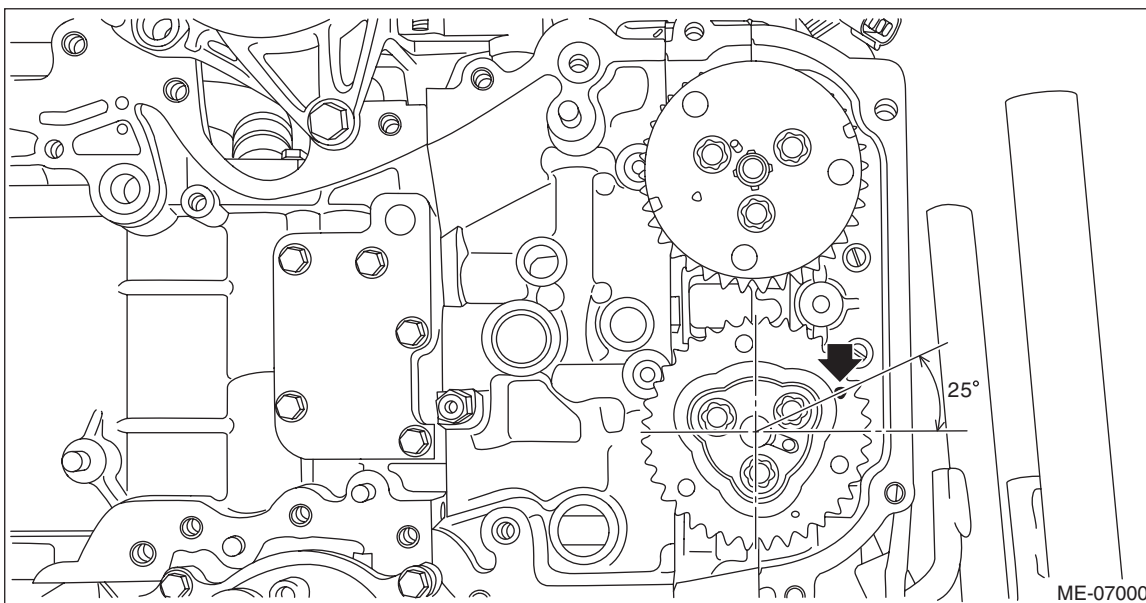

Timing Chain Assembly

MECHANICAL

- 6) Install the timing chain LH and the timing chain guide LH.
 - (1) Match the timing chain mark (blue) to the alignment mark of the crank sprocket.
 - (2) Match the timing chain mark (pink) to the timing mark position of the intake cam sprocket LH.
 - (3) Match the timing chain mark (pink) to the timing mark position of the exhaust cam sprocket LH.
 - (4) Install timing chain guide LH.

Tightening torque:

6.4 N·m (0.7 kgf·m, 4.7 ft·lb)

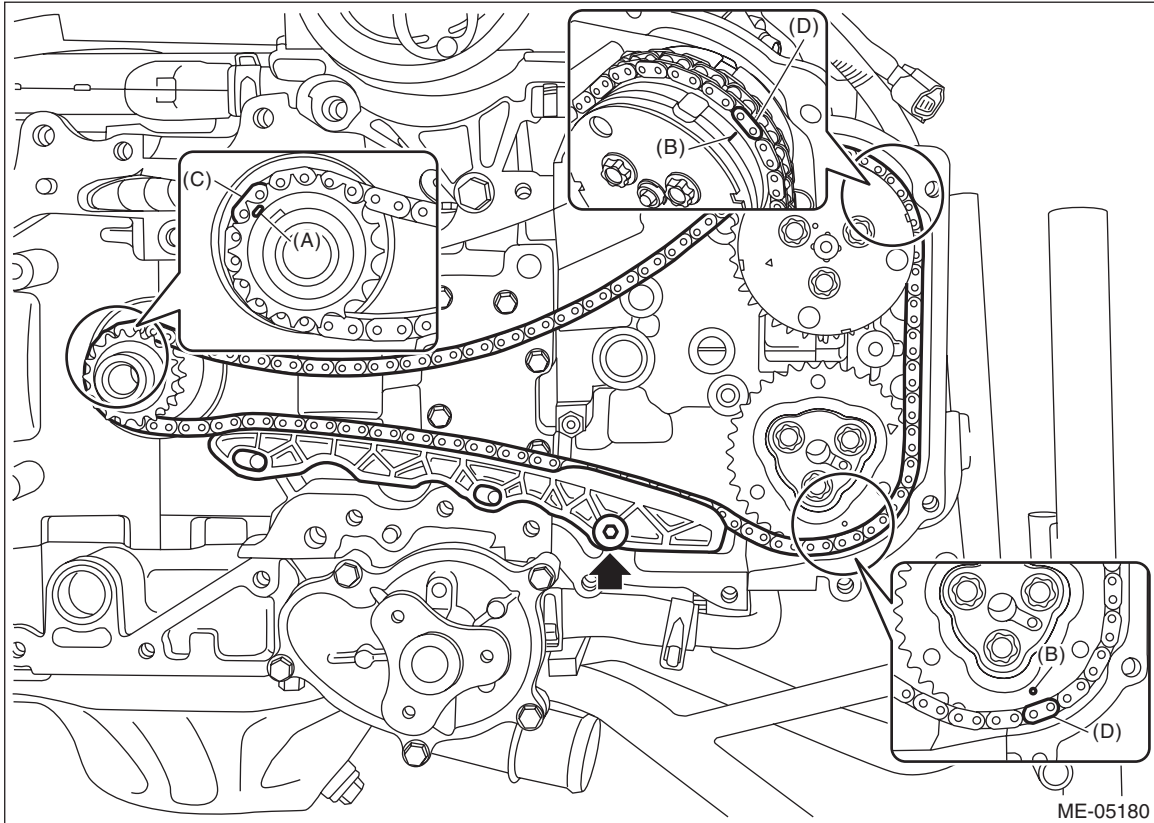

(A) Alignment mark
(B) Timing mark

(C) Blue

(D) Pink

Timing Chain Assembly

MECHANICAL

7) Install O-rings to the cylinder block LH.

NOTE:

Use new O-rings.

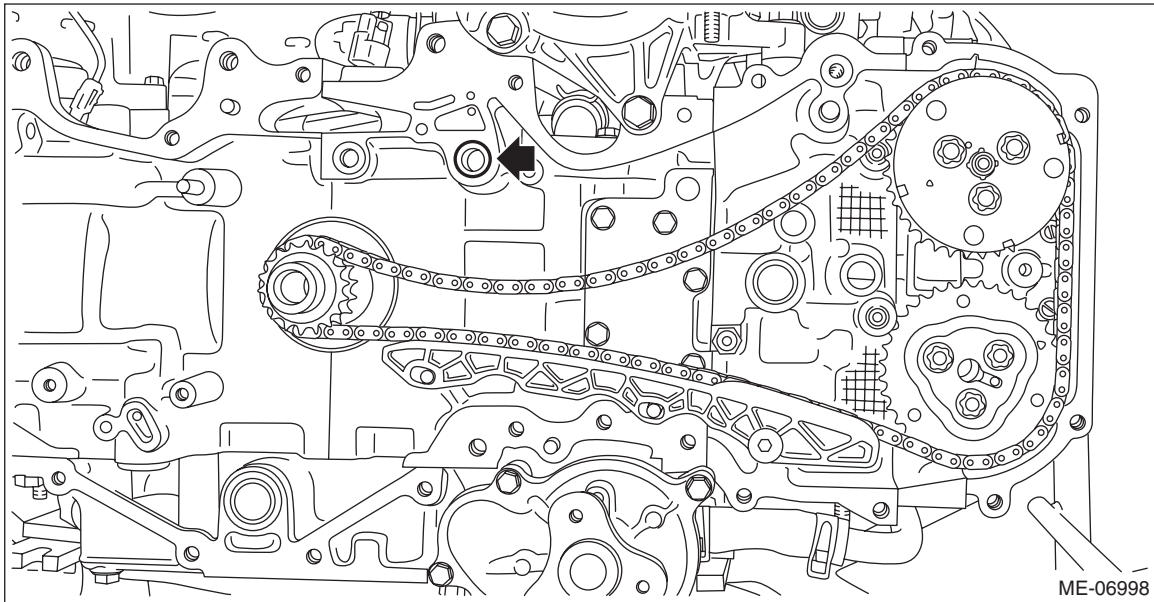

8) Install the chain tensioner lever LH (A) and chain tensioner LH.

Tightening torque:

6.4 N·m (0.7 kgf-m, 4.7 ft-lb)

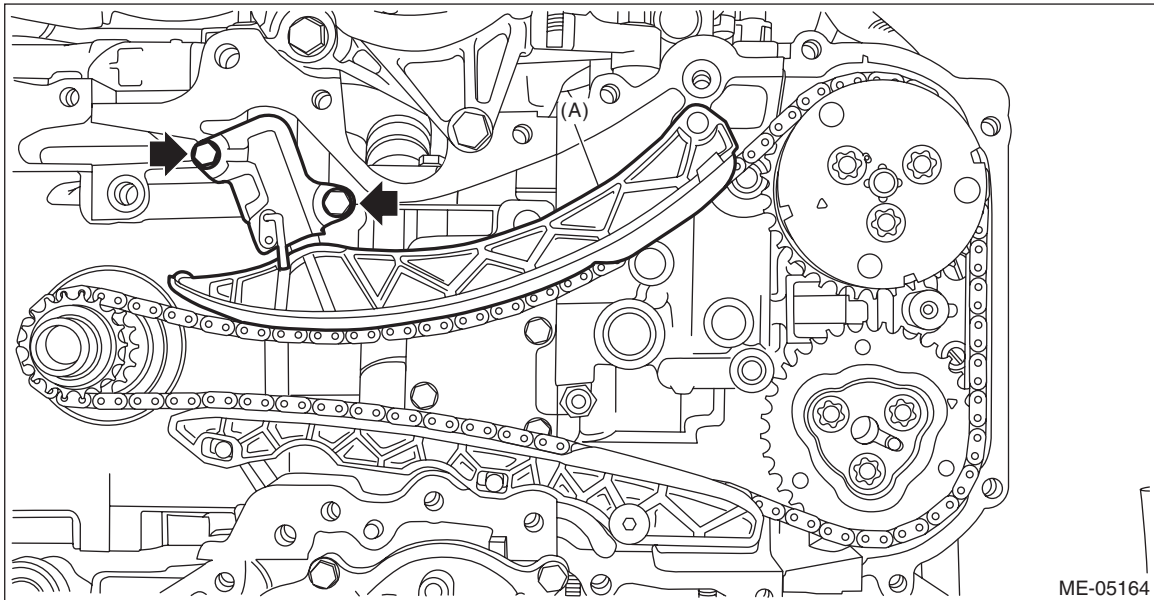

Timing Chain Assembly

MECHANICAL

9) Pull out the stopper pin from the chain tensioner LH.

CAUTION:

Confirm the following before pulling out the stopper pin.

- Matching of the timing chain mark (blue) to the alignment mark of the crank sprocket.
- Matching of the timing chain mark (pink) to the timing mark position of the intake cam sprocket LH.
- Matching of the timing chain mark (pink) to the timing mark position of the exhaust cam sprocket LH.

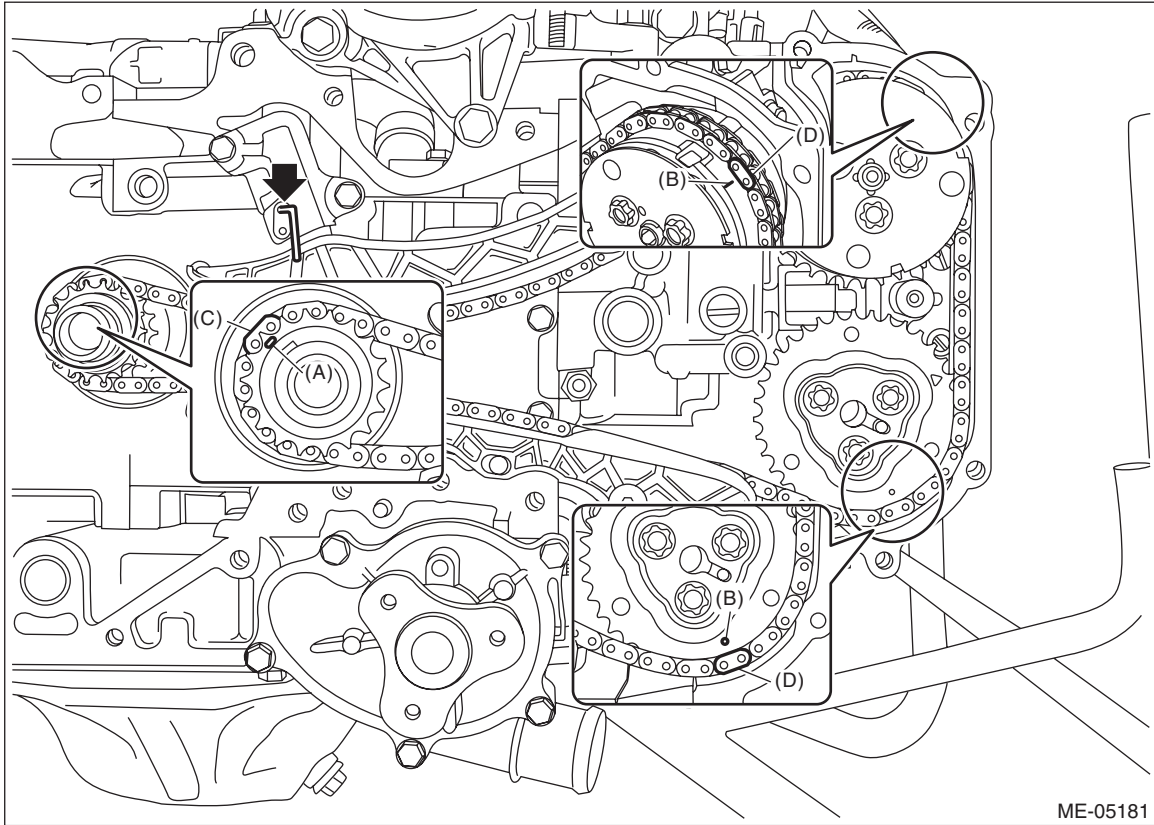

(A) Alignment mark
(B) Timing mark

(C) Blue

(D) Pink

Timing Chain Assembly

MECHANICAL

10) Using the ST, turn the crankshaft clockwise, and make sure that there are no abnormal conditions.

CAUTION:

Always make sure to perform this confirmation.

ST 18252AA000 CRANKSHAFT SOCKET

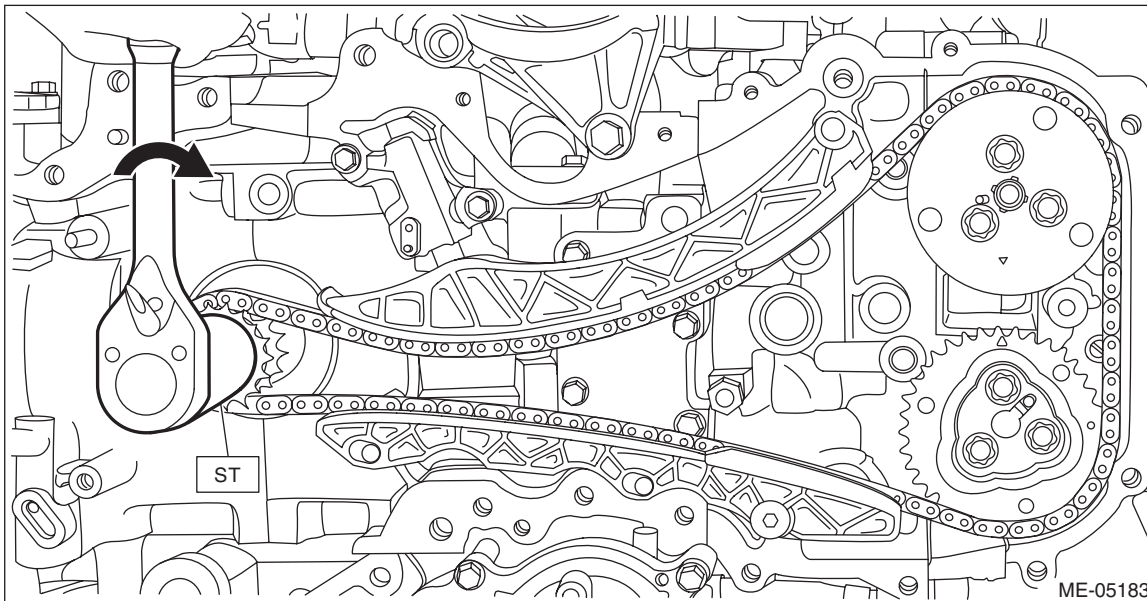

11) Using ST and by turning the crankshaft, align the alignment marks of crank sprocket, intake cam sprocket LH and exhaust cam sprocket LH to the positions as shown in the figure.

NOTE:

If the alignment marks are aligned to the positions as shown in the figure, the crankshaft key is located at six o'clock position.

ST 18252AA000 CRANKSHAFT SOCKET

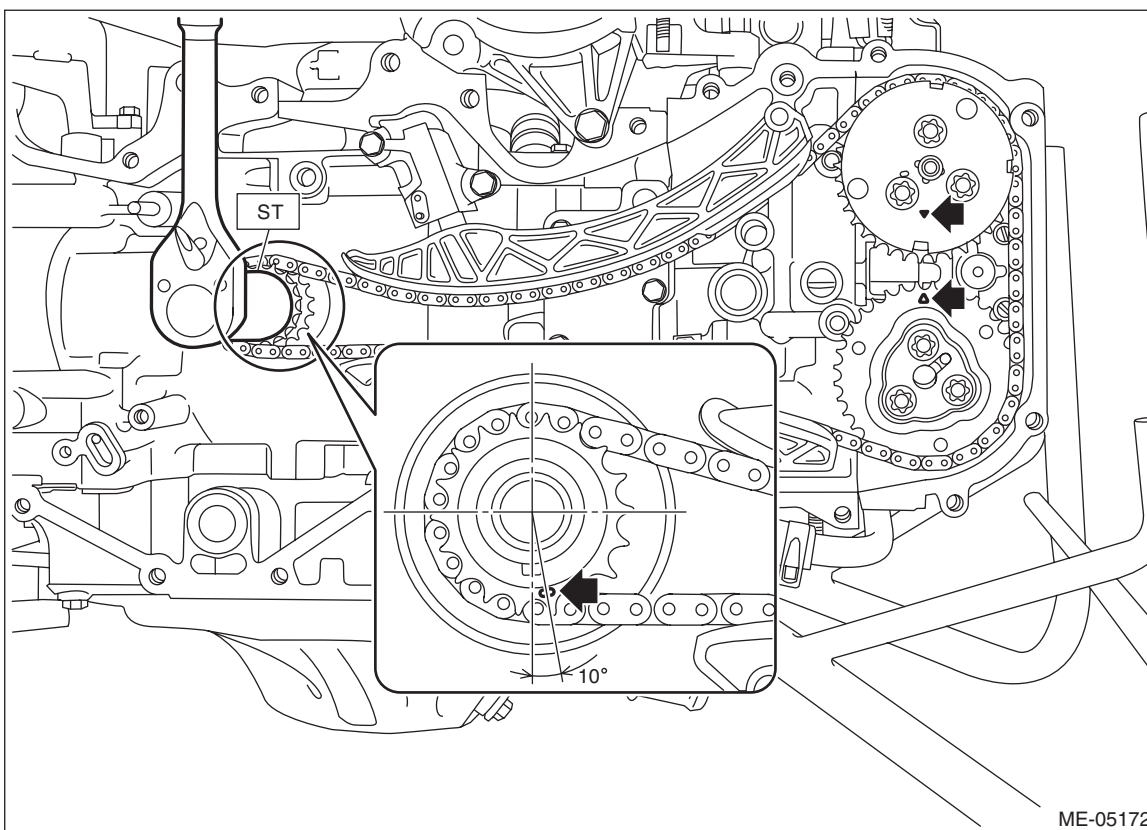

Timing Chain Assembly

MECHANICAL

12) Install the timing chain RH. <Ref. to ME(H4DO)-126, TIMING CHAIN RH, INSTALLATION, Timing Chain Assembly.>

2. TIMING CHAIN RH

NOTE:

- Be careful that the foreign matter is not into or onto the assembled component during installation.
- Apply engine oil to all component parts of the timing chain.

1) Install timing chain LH. <Ref. to ME(H4DO)-118, TIMING CHAIN LH, INSTALLATION, Timing Chain Assembly.>

2) Prepare to attach the chain tensioner RH.

(1) Move the link plate (A) in the direction of arrow to press in the plunger (B).

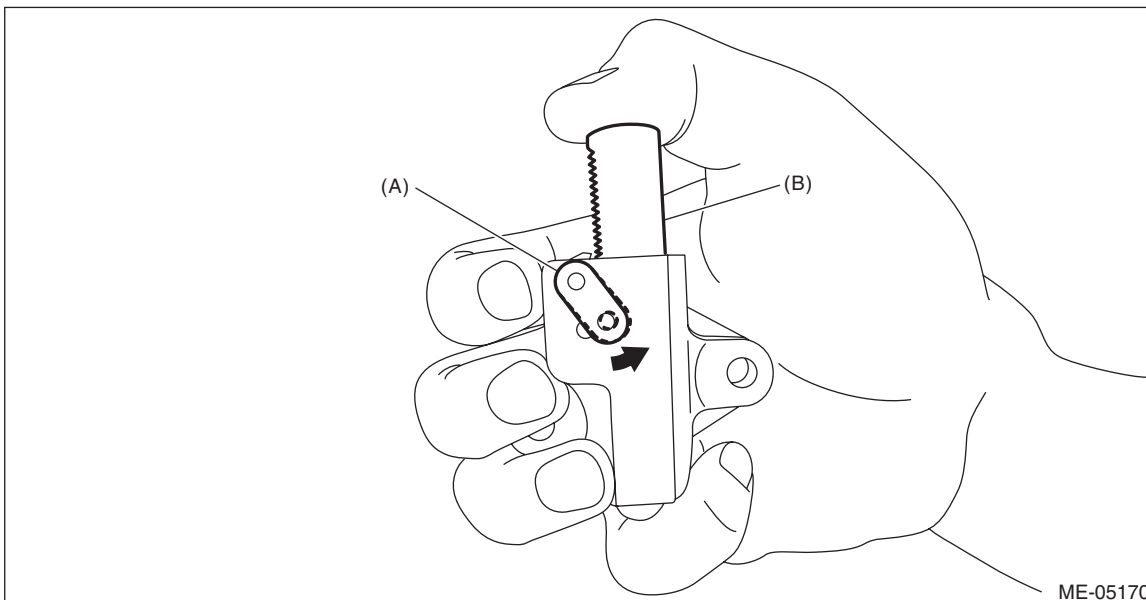

(2) With a 2.5 mm (0.98 in) dia. stopper pin or a 2.5 mm (0.98 in) (nominal) dia. hex wrench inserted into the stopper pin hole, secure the plunger.

NOTE:

If the stopper pin hole on the link plate and the stopper pin hole on the chain tensioner are not aligned, check that the first notch of plunger rack (A) is engaged with the stopper tooth (B). If not engaged, retract the plunger a little so that the first notch of plunger rack (A) is engaged with the stopper tooth (B).

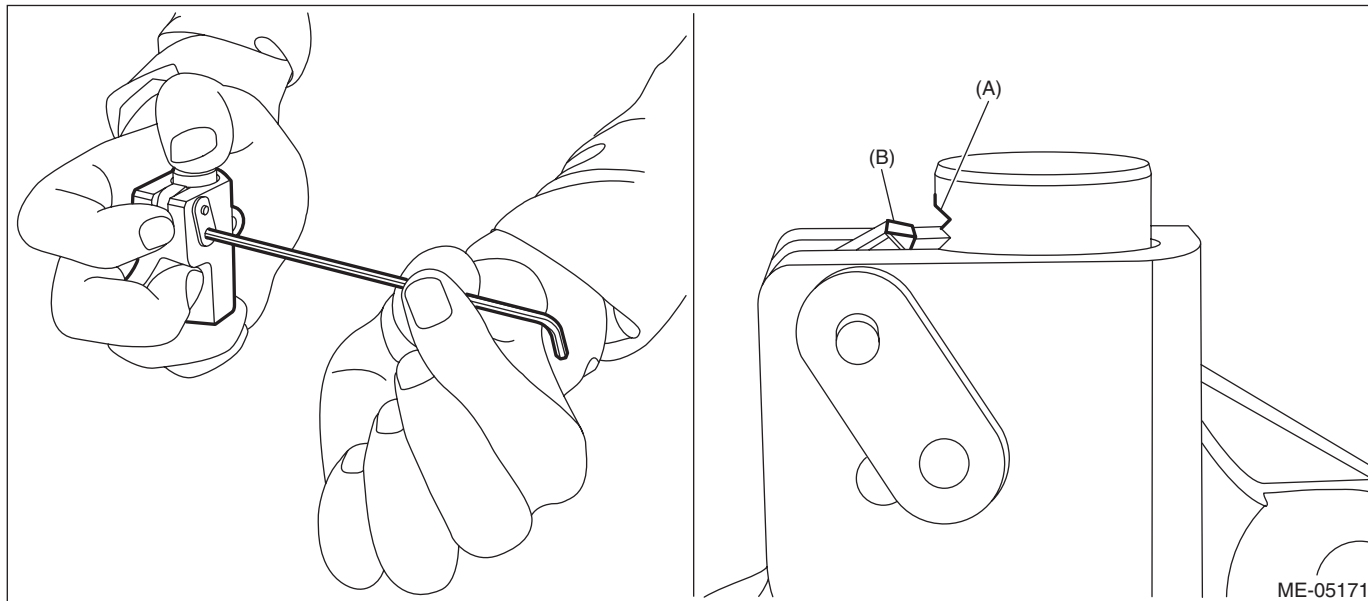

Timing Chain Assembly

MECHANICAL

3) Make sure that the alignment marks of the crank sprocket, intake cam sprocket LH and exhaust cam sprocket LH are aligned to the positions as shown in the figure.

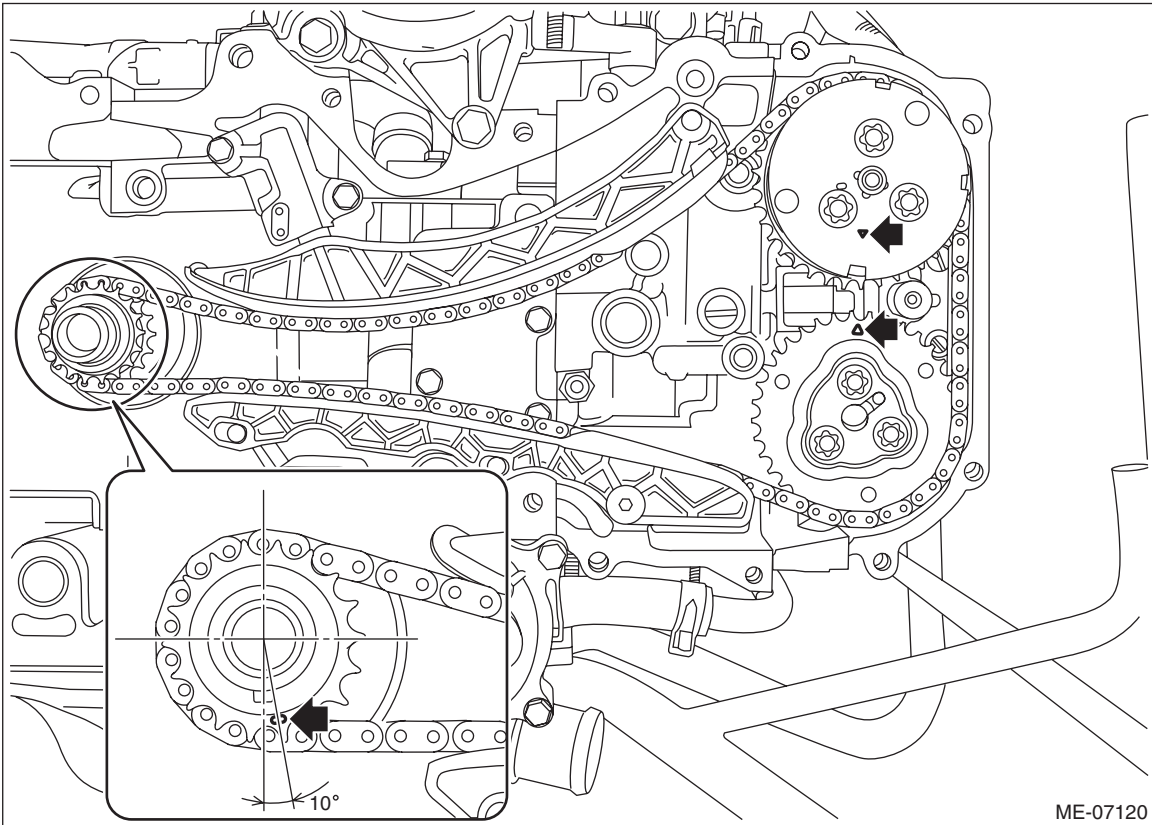

4) Align the alignment marks of intake cam sprocket RH and exhaust cam sprocket RH to the positions as shown in the figure.

CAUTION:

To prevent valve damage, turn the intake cam sprocket RH and exhaust cam sprocket RH only within the range of zero-lift (in range where it can be turned lightly by hand).

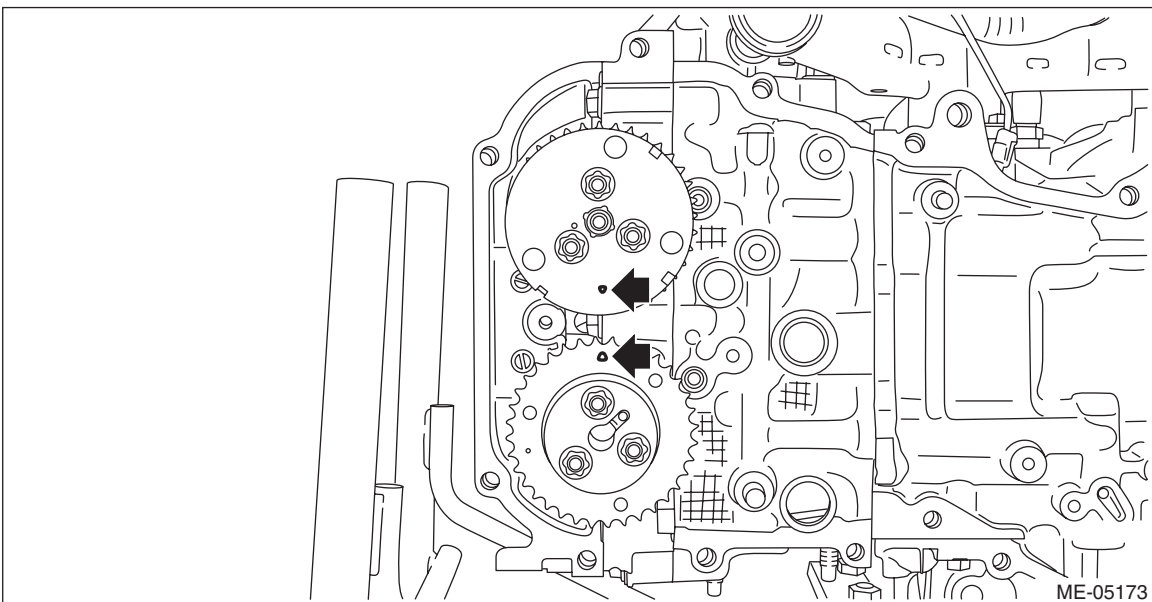

Timing Chain Assembly

MECHANICAL

- 5) Install the timing chain RH and the timing chain guide RH.
 - (1) Match the timing chain mark (blue) to the alignment mark of the crank sprocket.
 - (2) Match the timing chain mark (pink) to the timing mark position of the intake cam sprocket RH.
 - (3) Match the timing chain mark (pink) to the timing mark position of the exhaust cam sprocket RH.
 - (4) Install the timing chain guide RH.

Tightening torque:

6.4 N·m (0.7 kgf·m, 4.7 ft·lb)

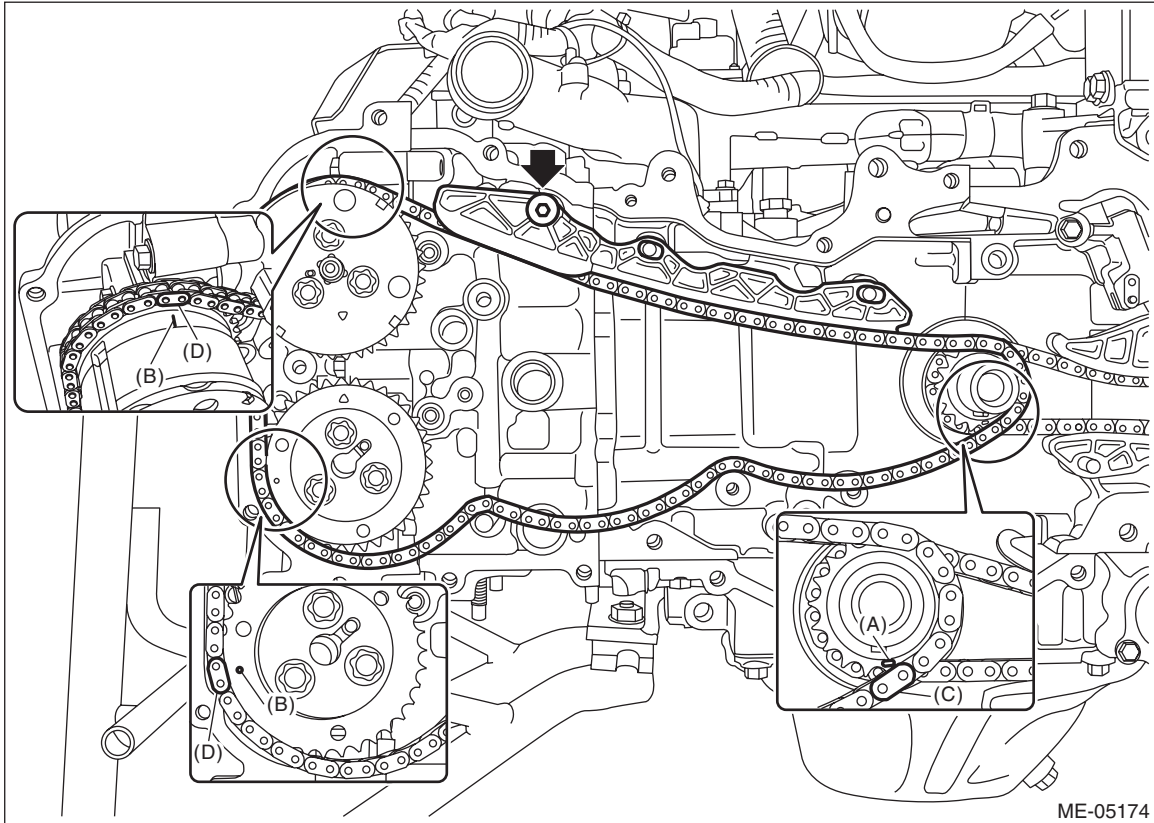

(A) Alignment mark
(B) Timing mark

(C) Blue

(D) Pink

Timing Chain Assembly

MECHANICAL

6) Install the chain tensioner lever RH (A) and chain tensioner RH.

Tightening torque:

6.4 N·m (0.7 kgf-m, 4.7 ft-lb)

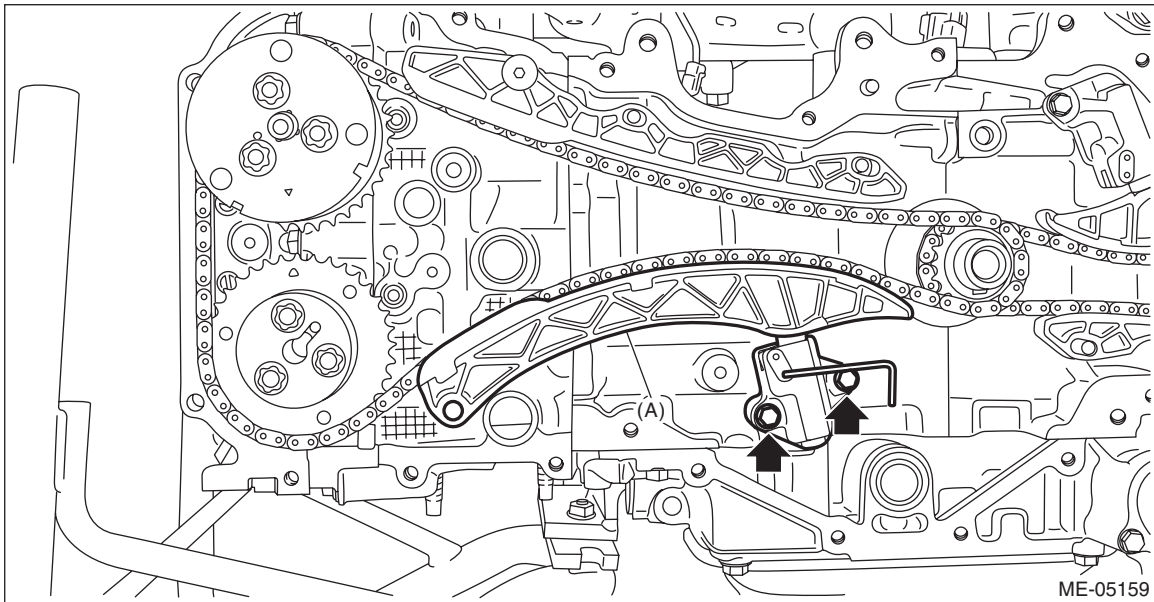

ME-05159

Timing Chain Assembly

MECHANICAL

7) Pull out the stopper pin from the chain tensioner RH.

CAUTION:

Confirm the following before pulling out the stopper pin.

- Matching of the timing chain mark (blue) to the alignment mark of the crank sprocket.
- Matching of the timing chain mark (pink) to the timing mark position of the intake cam sprocket RH.
- Matching of the timing chain mark (pink) to the timing mark position of the exhaust cam sprocket RH.

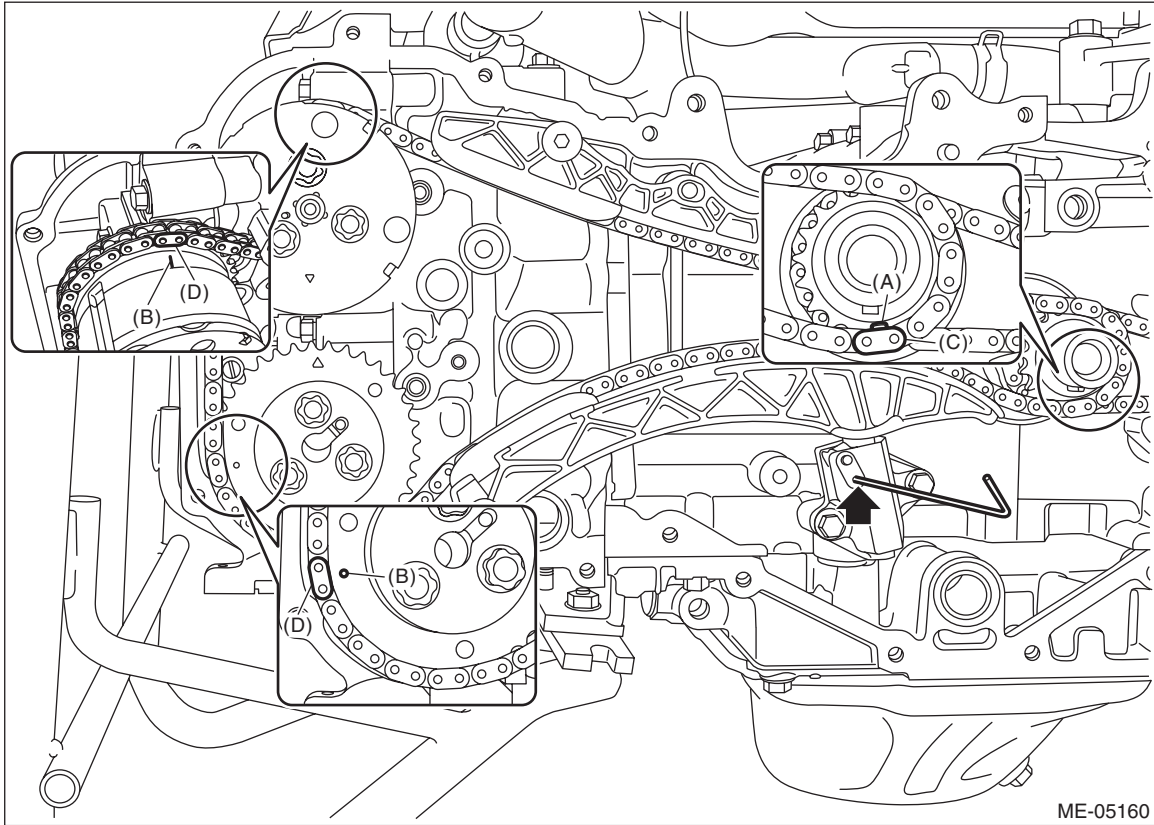

(A) Alignment mark
(B) Timing mark

(C) Blue

(D) Pink

Timing Chain Assembly

MECHANICAL

8) Make sure that the alignment marks of the cam sprocket and crank sprocket are aligned to the positions as shown in the figure.

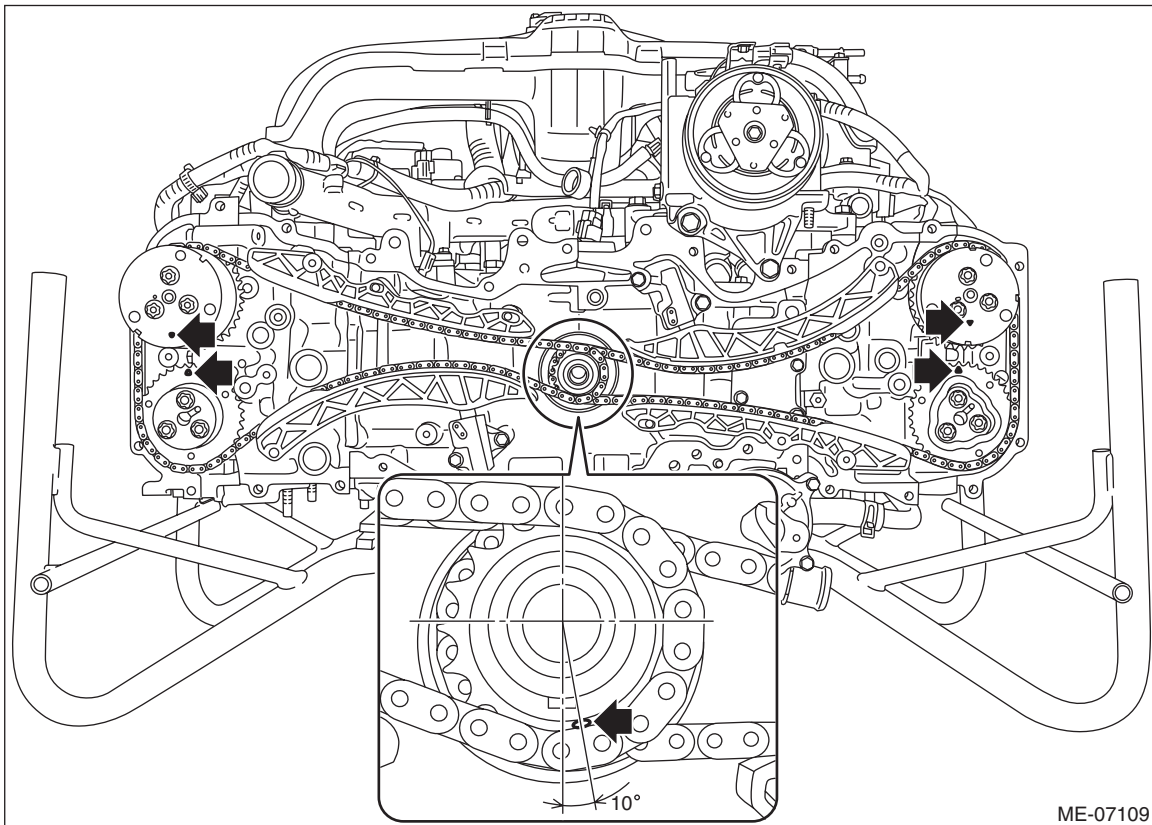

9) Using the ST, turn the crankshaft clockwise, and make sure that there are no abnormal conditions.

CAUTION:

Always make sure to perform this confirmation.

ST 18252AA000 CRANKSHAFT SOCKET

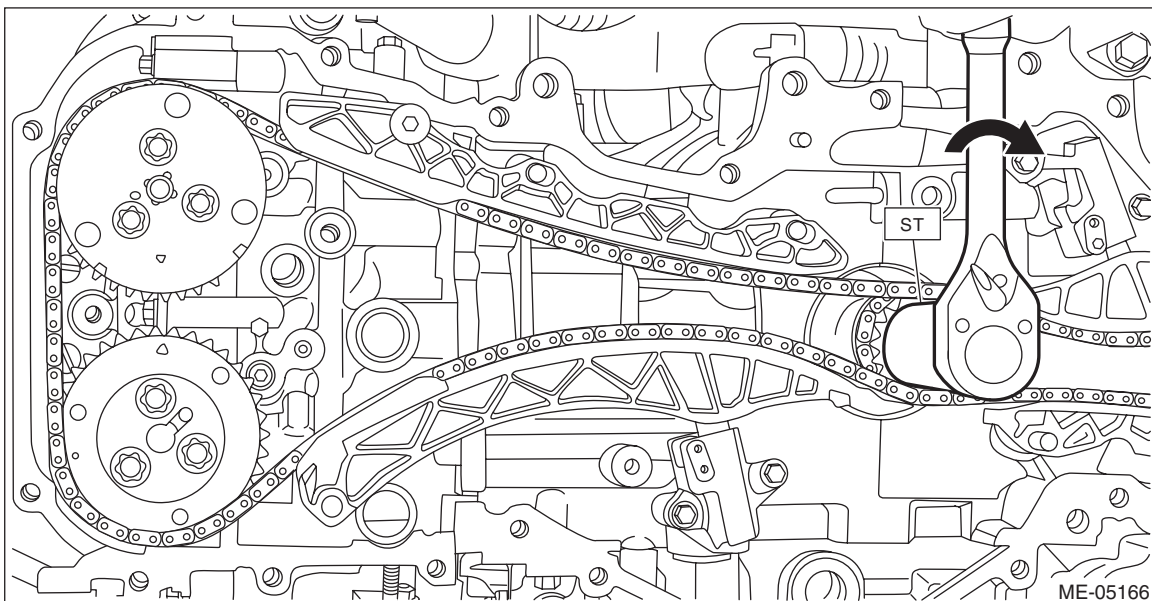

10) Install the chain cover. <Ref. to ME(H4DO)-102, INSTALLATION, Chain Cover.>

Timing Chain Assembly

MECHANICAL

C: INSPECTION

- 1) Check the timing chain, chain guide, chain tensioner lever and chain tensioner for deformation, cracks or other damages.
- 2) Check the chain guide and chain tensioner lever for abnormal wear.