

Fuel Pressure

MECHANICAL

7. Fuel Pressure

A: INSPECTION

CAUTION:

- Before removing the fuel pressure gauge, release the fuel pressure.
- Be careful not to spill fuel.
- Catch the fuel from hoses using a container or cloth.

- 1) Release the fuel pressure. <Ref. to FU(H4DO)-109, RELEASING OF FUEL PRESSURE, PROCEDURE, Fuel.>
- 2) Open the fuel filler lid and remove the fuel filler cap.
- 3) Disconnect the fuel delivery hose from the fuel delivery pipe, and connect the fuel pressure gauge.

CAUTION:

- Be careful not to spill fuel.
- Catch the fuel from hoses using a container or cloth.

(1) Attach ST to the fuel delivery pipe and push ST in the direction of arrow mark to disconnect the quick connector of the fuel delivery hose.

ST 42099AE000 QUICK CONNECTOR RELEASE

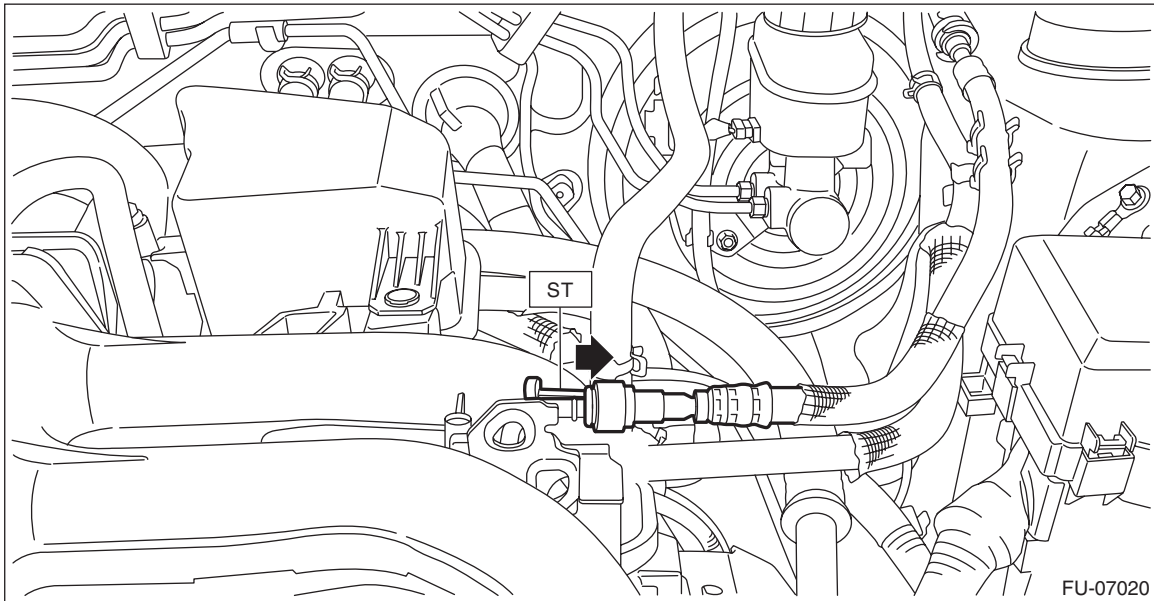

(2) Connect the fuel pressure gauge with ST1 and ST2.

NOTE:

ST1 is a SUBARU genuine part.

ST1 42075AG690 FUEL HOSE

ST2 18471AA000 FUEL PIPE ADAPTER

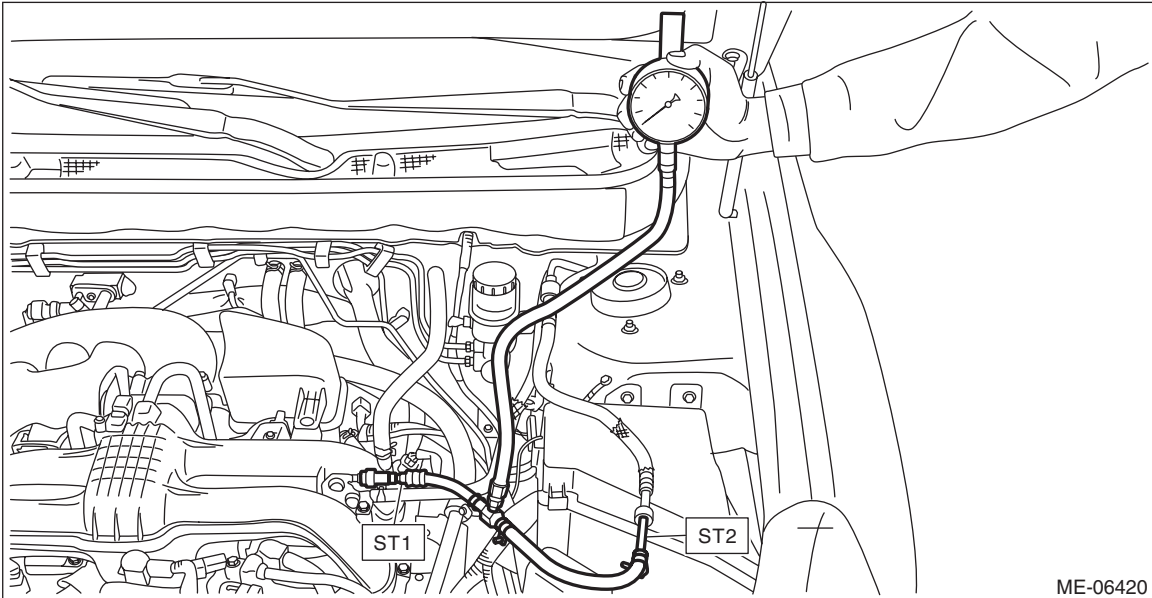

4) Start the engine.

5) Check the fuel pressure after warming up the engine.

NOTE:

- The fuel pressure gauge registers 10 to 20 kPa (0.1 to 0.2 kgf/cm², 1 to 3 psi) higher than standard values during high-altitude operations.
- Check or replace the fuel pump and fuel delivery line if the fuel pressure is out of the standard.

Fuel pressure:

Standard

340 — 400 kPa (3.5 — 4.1 kgf/cm², 49 — 58 psi)

6) After inspection, install the related parts in the reverse order of removal.