

9. Engine Assembly

A: REMOVAL

1) Change the front hood damper mounting position from (A) to (B), and completely open the front hood.

Tightening torque:

20 N·m (2.0 kgf-m, 14.8 ft-lb)

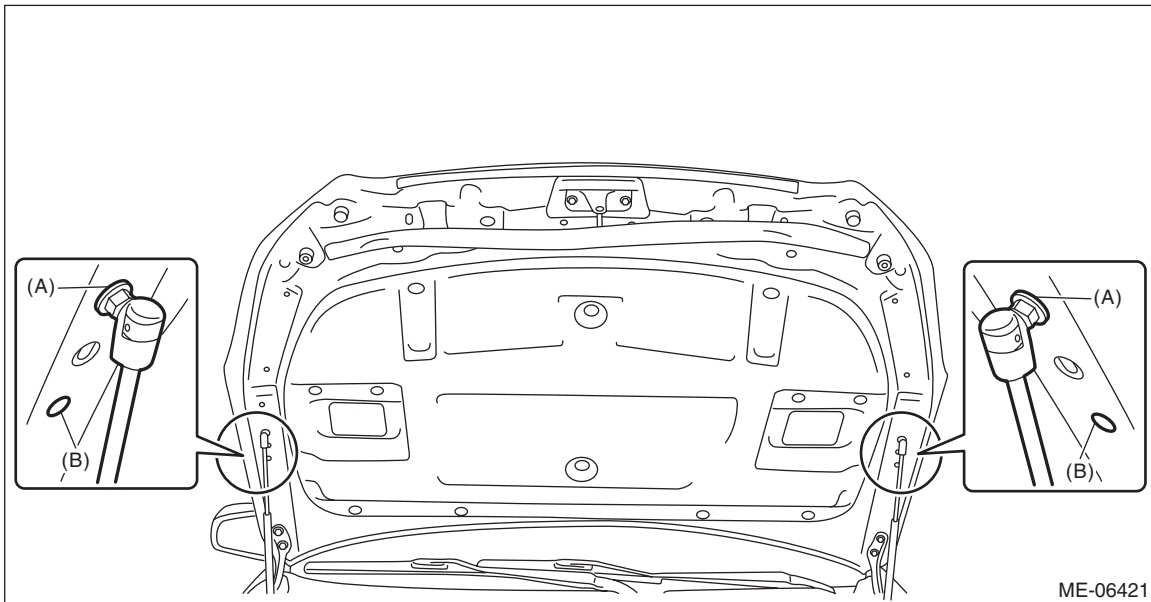

2) Remove the V-belt covers.

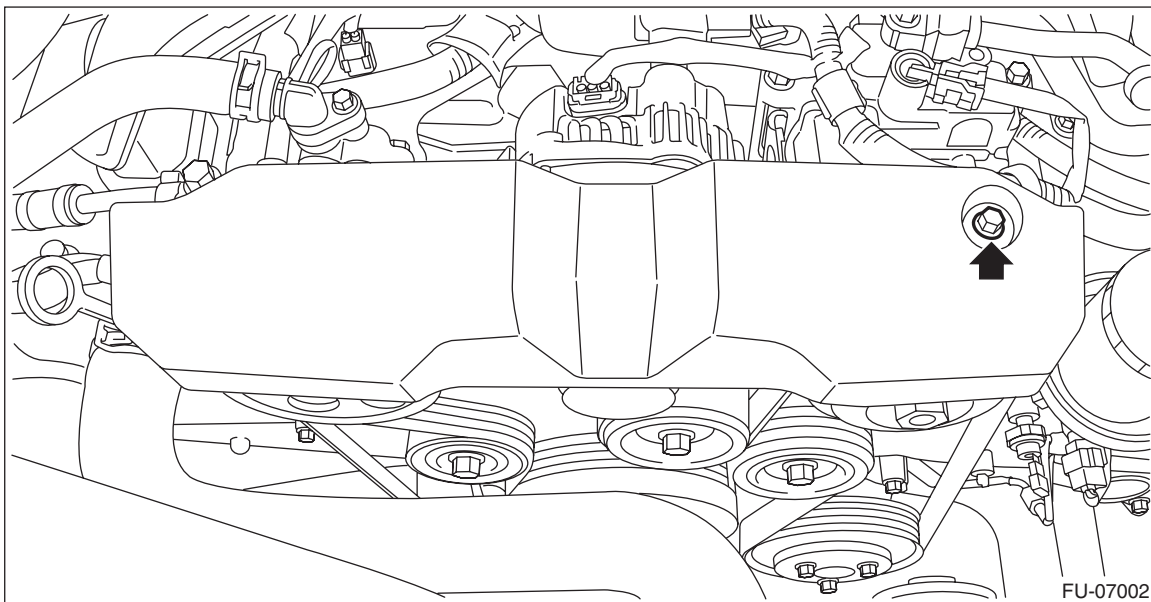

3) Collect the refrigerant from A/C system. <Ref. to AC-26, Refrigerant Recovery Procedure.>

4) Release the fuel pressure. <Ref. to FU(H4DO)-109, RELEASING OF FUEL PRESSURE, PROCEDURE, Fuel.>

Engine Assembly

MECHANICAL

5) Disconnect the ground cable from battery.

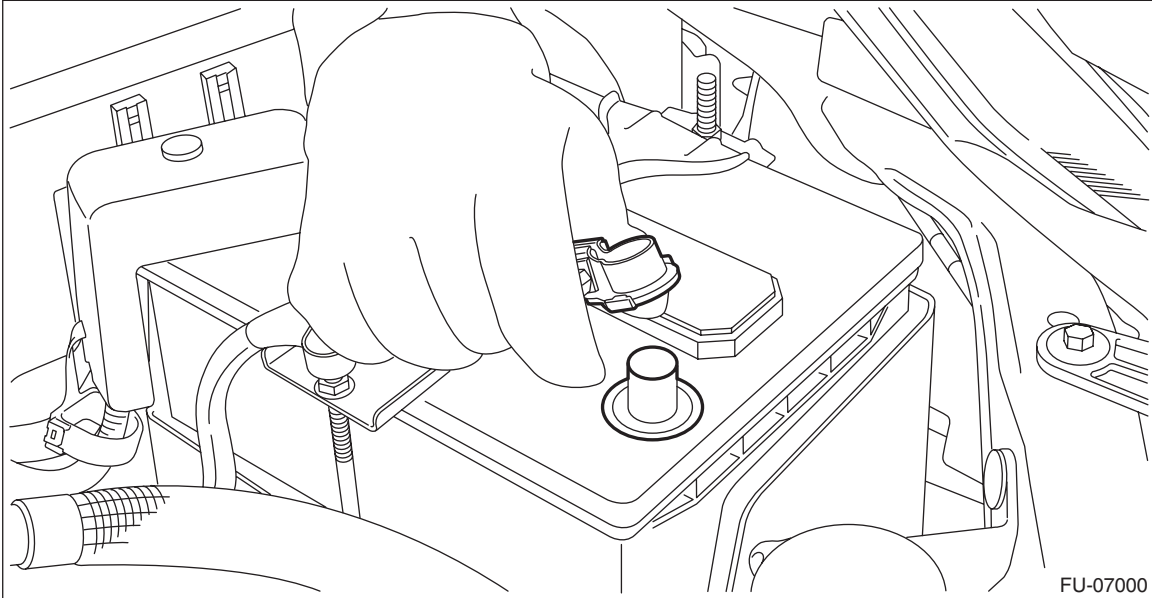

6) Open the fuel filler lid and remove the fuel filler cap.

7) Remove the air intake duct. <Ref. to IN(H4DO)-14, REMOVAL, Air Intake Duct.>

8) Remove the air intake boot. <Ref. to IN(H4DO)-13, REMOVAL, Air Intake Boot.>

9) Disconnect the connector (A) from the mass air flow and intake air temperature sensor, and remove the clip (B) which holds the mass air flow and intake air temperature sensor harness.

10) Remove the suction hose (C) from the air cleaner case (rear).

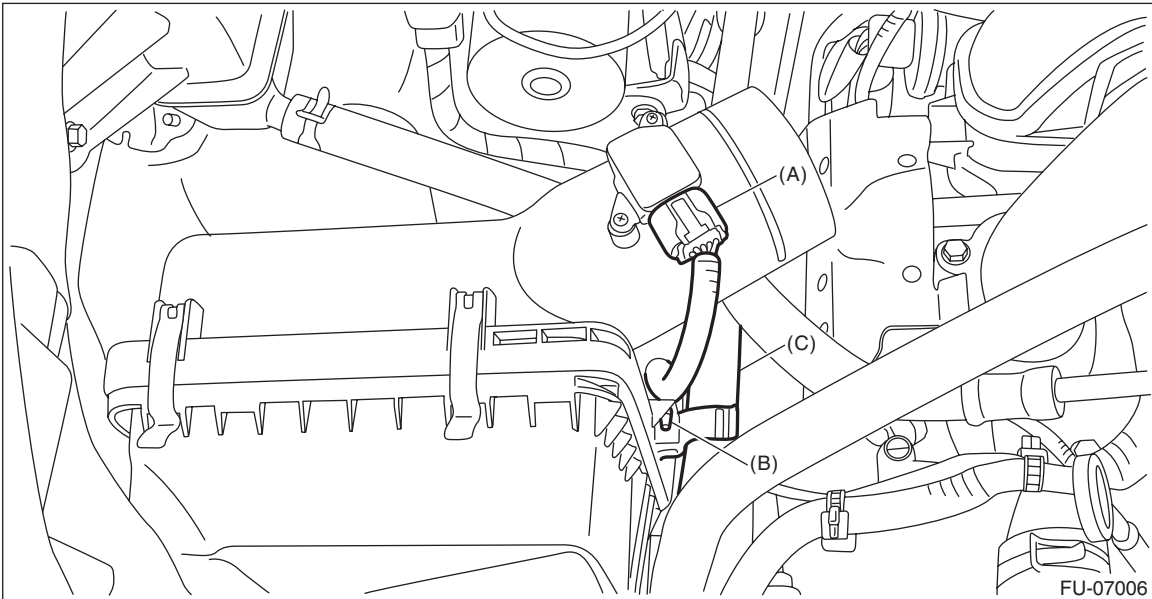

11) Remove the air cleaner case (rear).

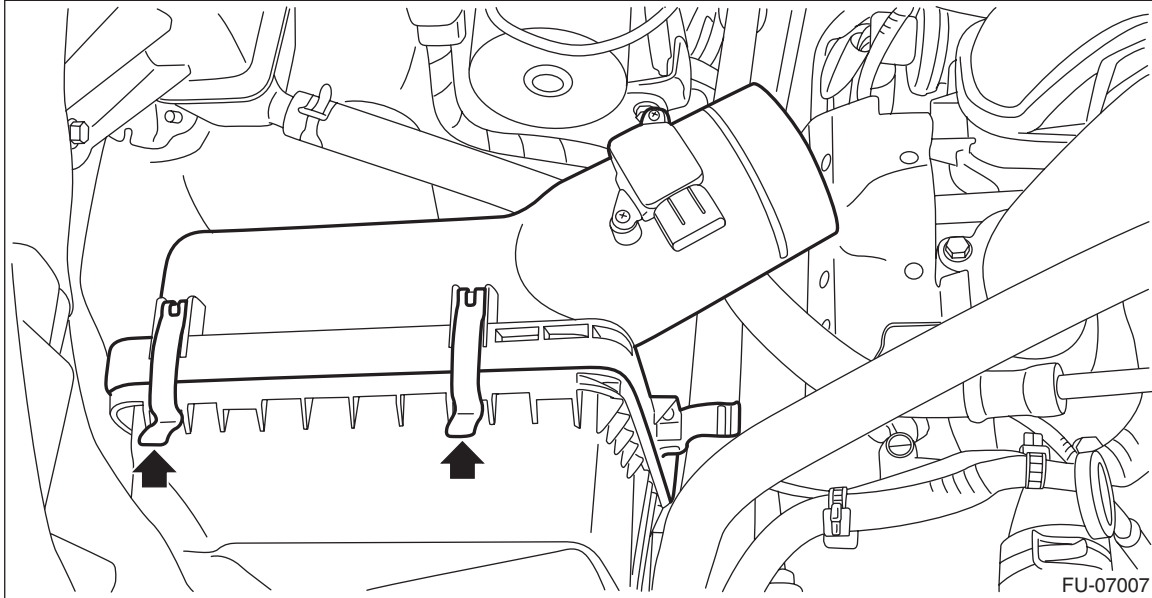

12) Remove the radiator. <Ref. to CO(H4DO)-25, REMOVAL, Radiator.>

13) Disconnect the brake booster vacuum hose from the intake manifold.

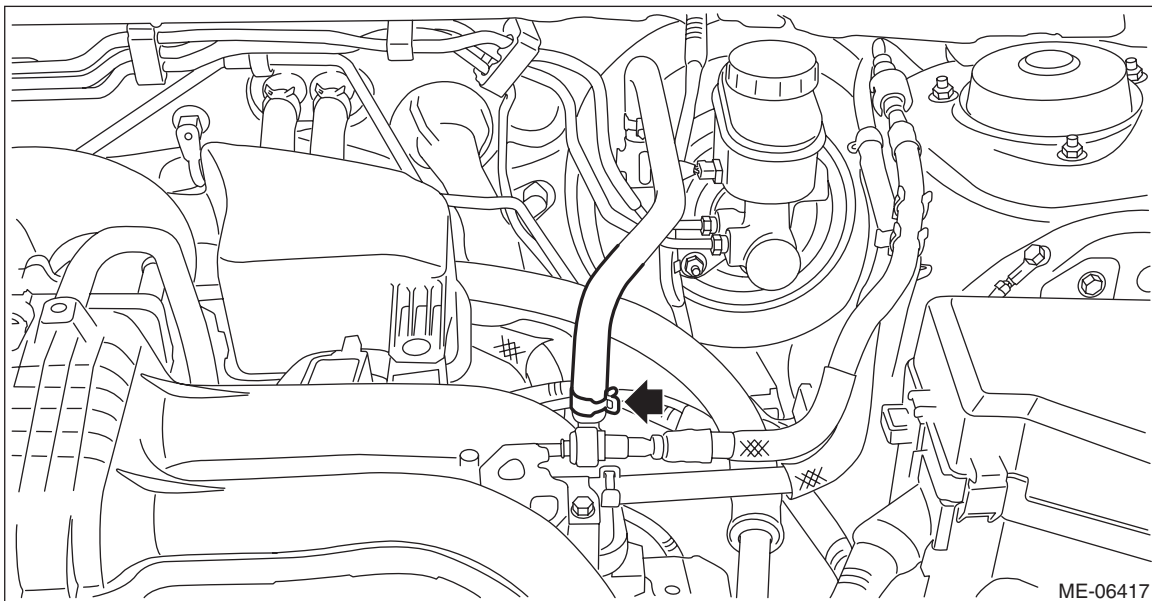

Engine Assembly

MECHANICAL

14) Disconnect the engine harness connector.

(1) Remove the bolt securing the bulkhead harness connector bracket.

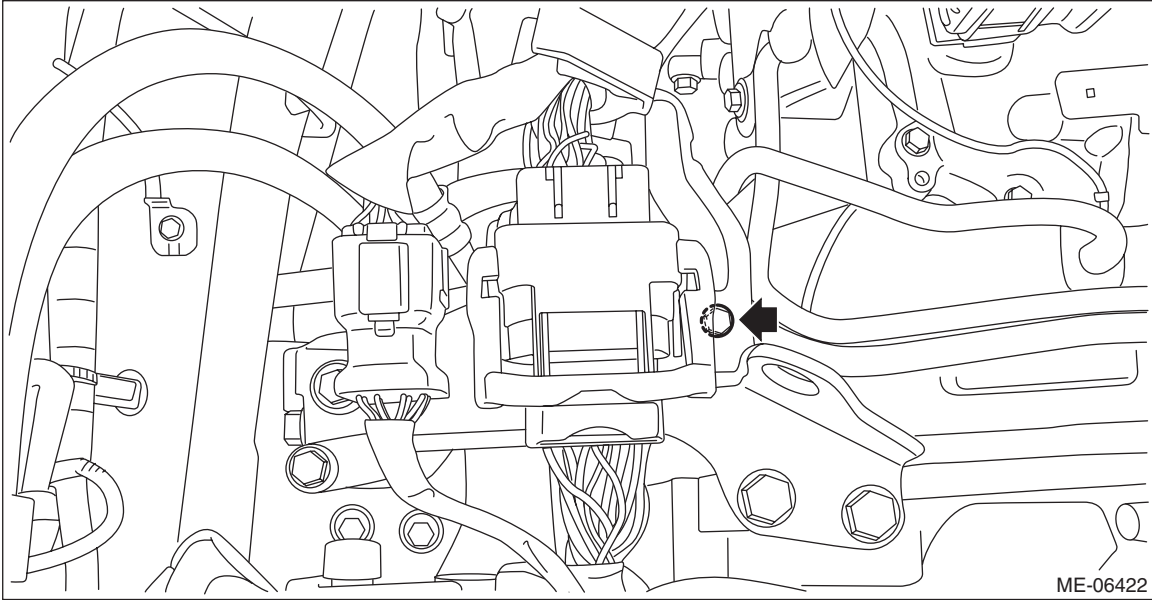

(2) Disconnect the bulkhead harness connector from the engine harness connector (black) and engine harness connector (brown).

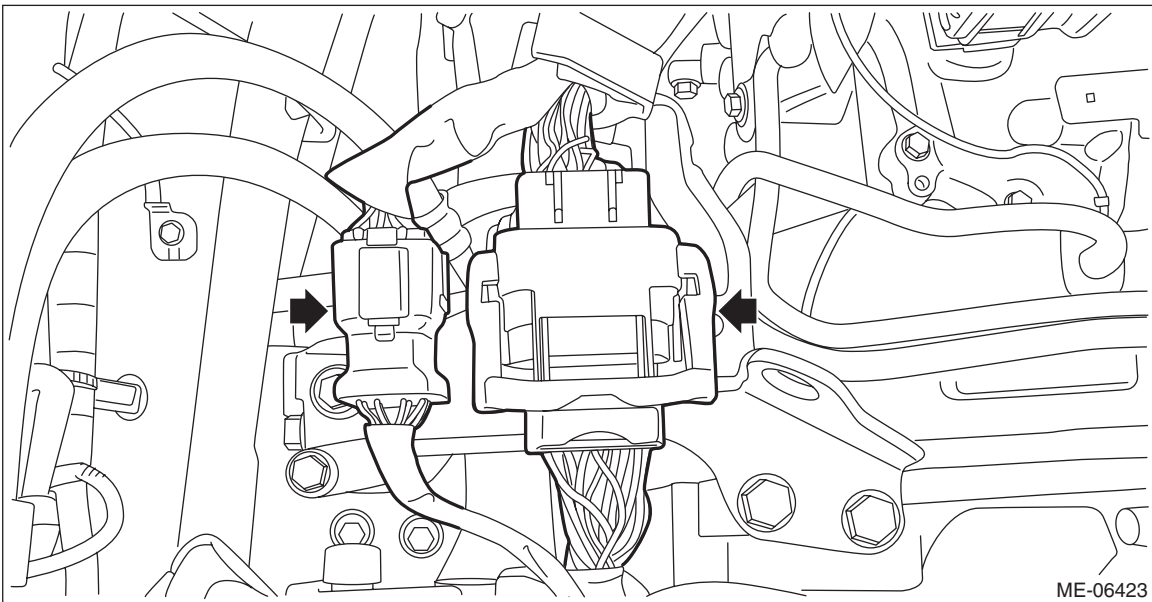

15) Remove the bolts which secure the generator cord stay to the chain cover.

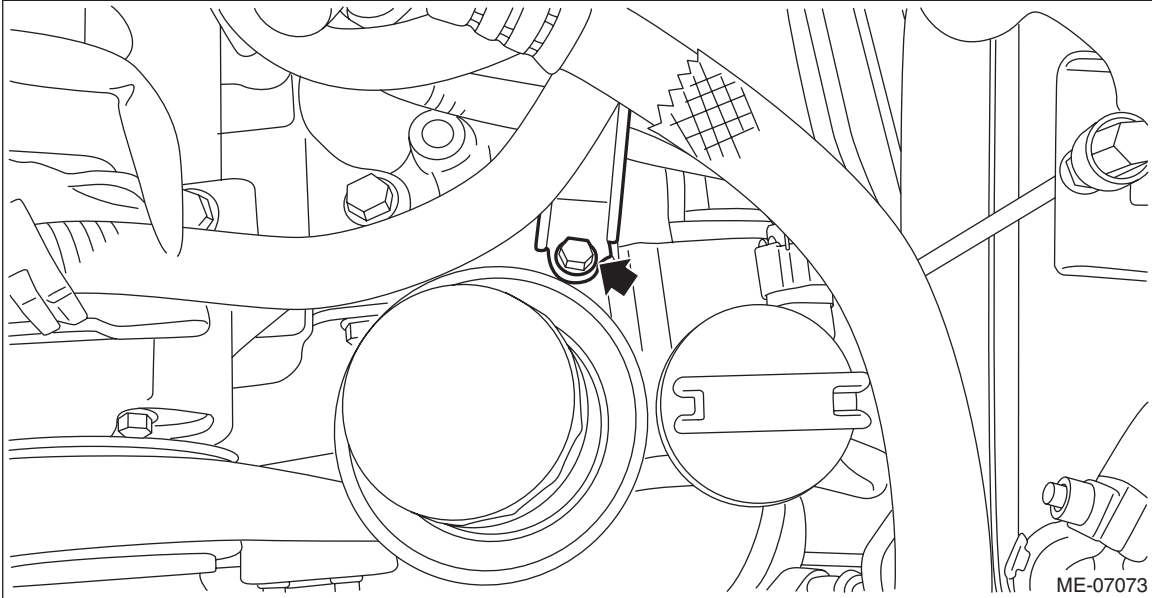

16) Disconnect the connectors (A) and (B) from the A/C compressor.

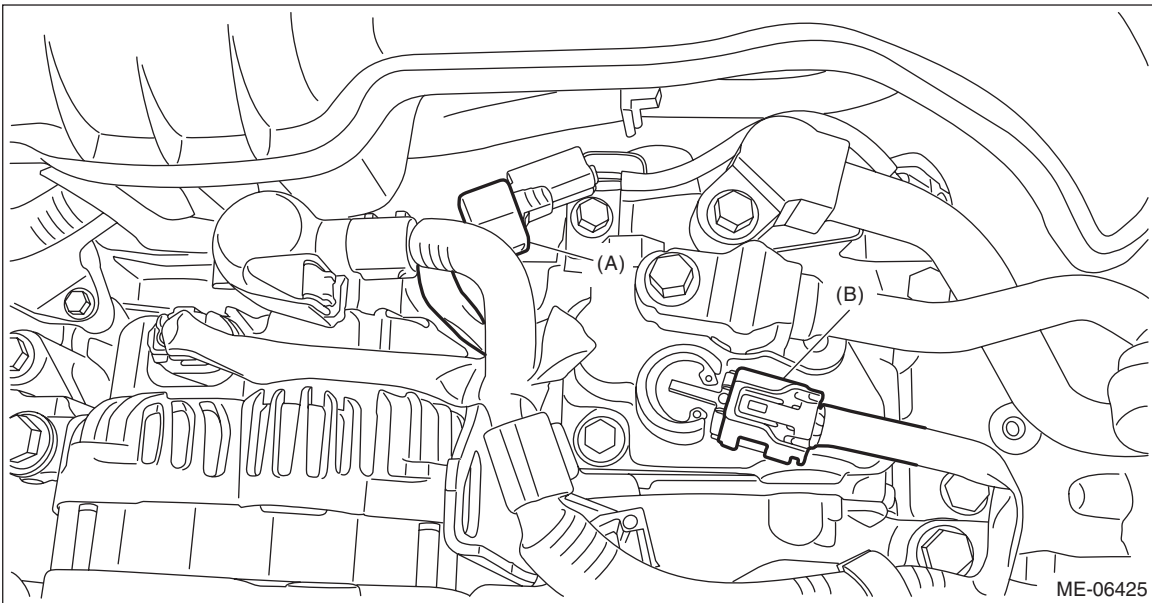

Engine Assembly

MECHANICAL

17) Disconnect the connector (A) and the terminal (B) from the generator, and disconnect the clip (C) which secures to the stay of the A/C compressor.

18) Remove the generator cord from the clip (D) and move the generator cord to the left side wheel apron.

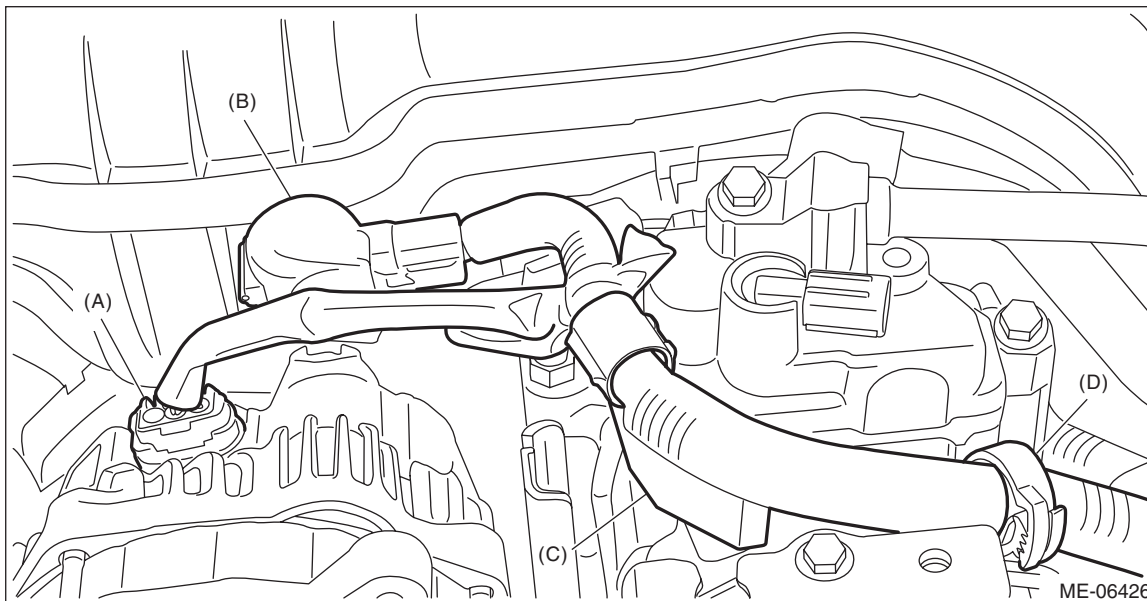

19) Disconnect the following hoses.

(1) A/C pressure hose <Ref. to AC-76, REMOVAL, Hose and Pipe.>

(2) Heater inlet hose and heater outlet hose

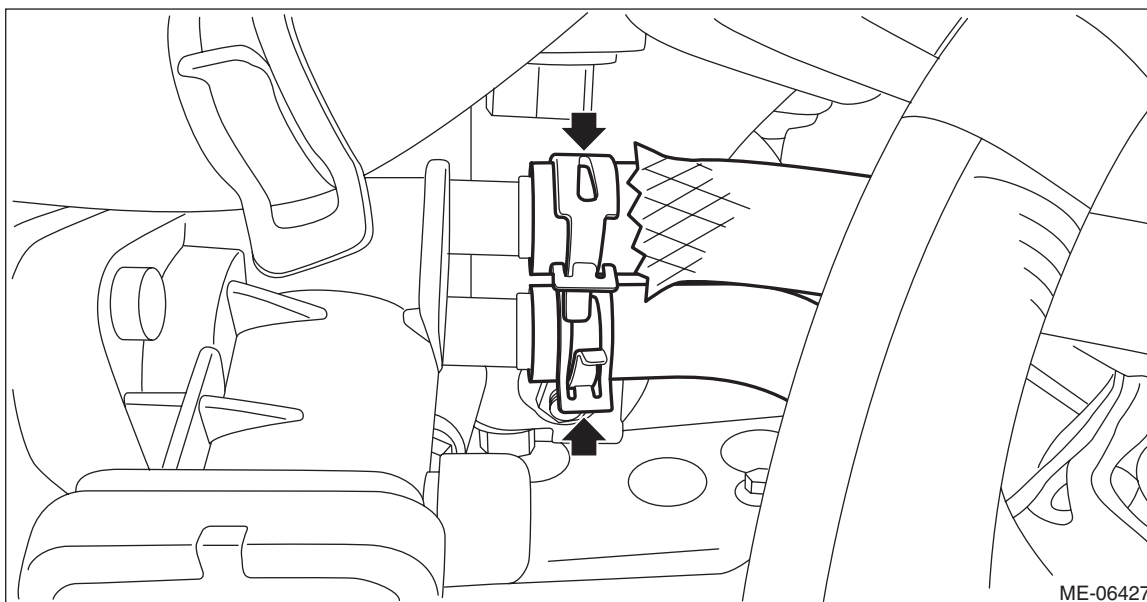

20) Remove the V-belts. <Ref. to ME(H4DO)-80, REMOVAL, V-belt.>

21) Remove the generator. <Ref. to SC(H4DO)-29, REMOVAL, Generator.>

22) Remove the power steering pump.

(1) Disconnect the connector from power steering pump.

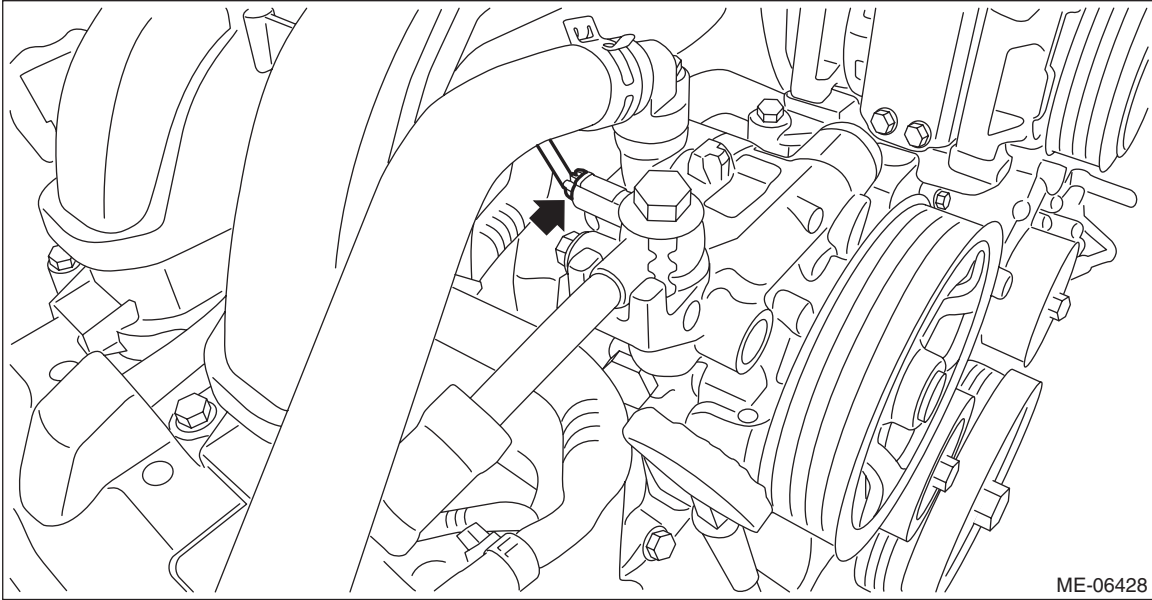

(2) Remove the power steering pump together with the power steering pump bracket from the engine.

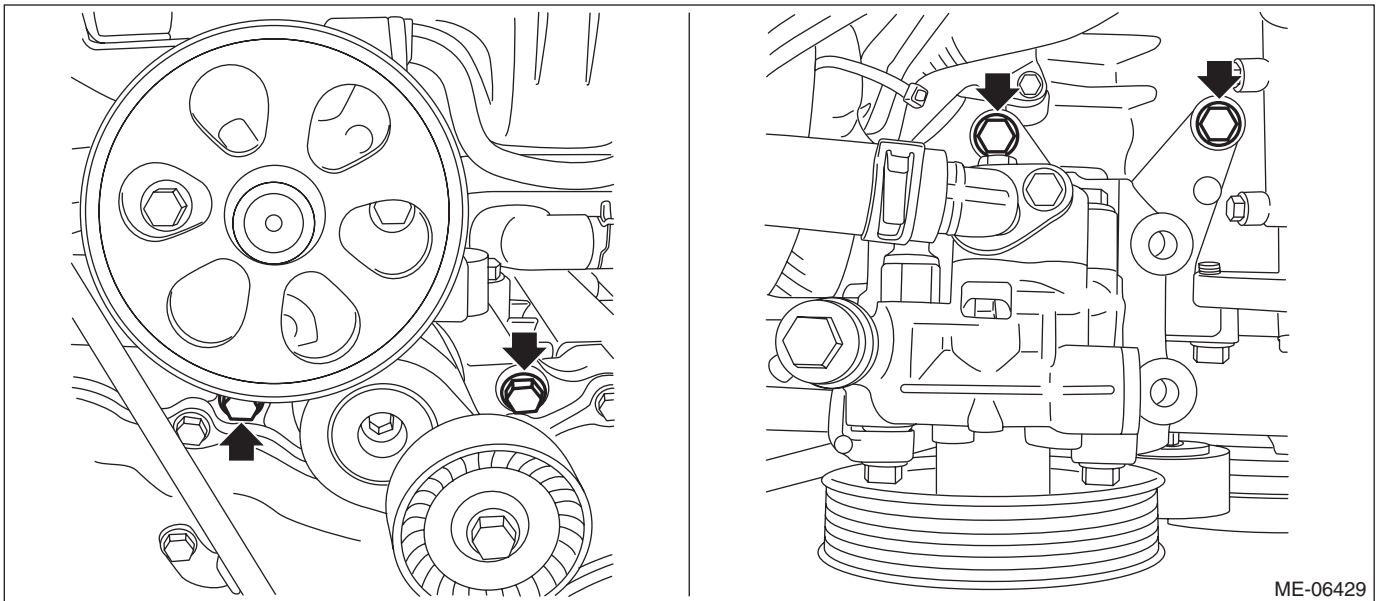

(3) Mount the power steering pump together with the power steering pump bracket on RH side wheel apron.

23) Lift up the vehicle.

24) Remove the front exhaust pipe. <Ref. to EX(H4DO)-5, REMOVAL, Front Exhaust Pipe.>

Engine Assembly

MECHANICAL

25) Disconnect the ground cable on the engine side.

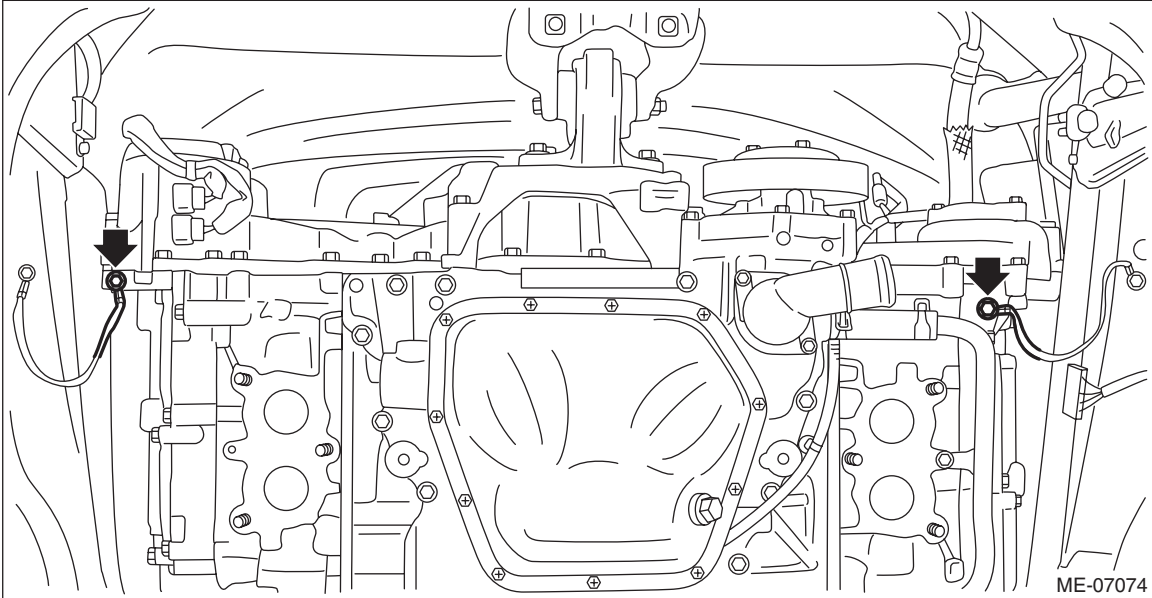

26) Remove the bolts and nuts which hold the lower side of transmission to the engine.

- CVT model

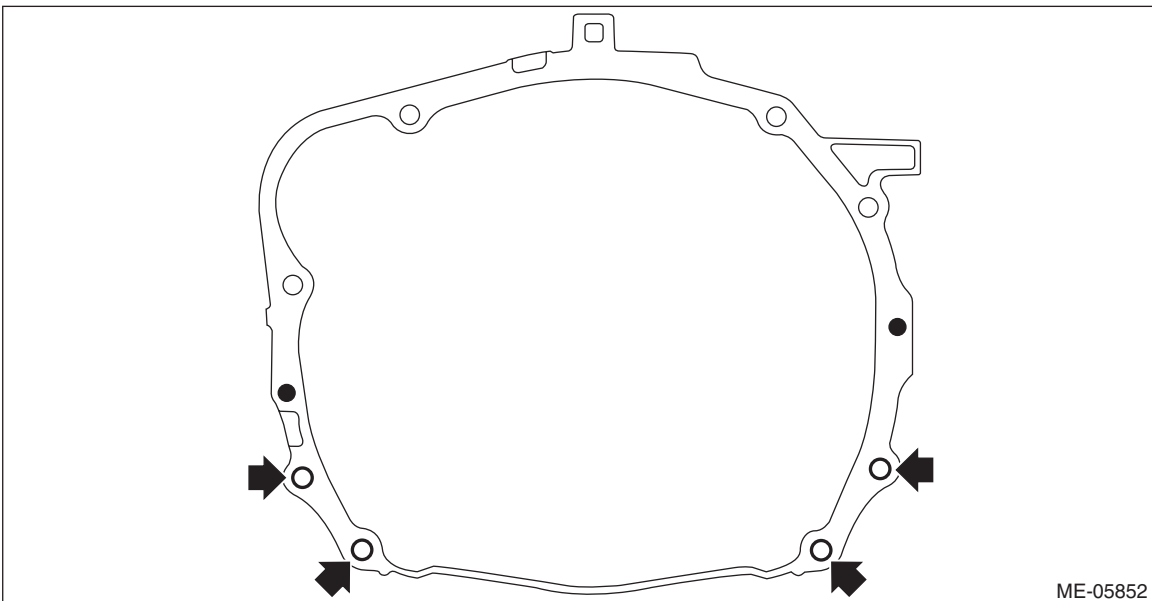

- MT model

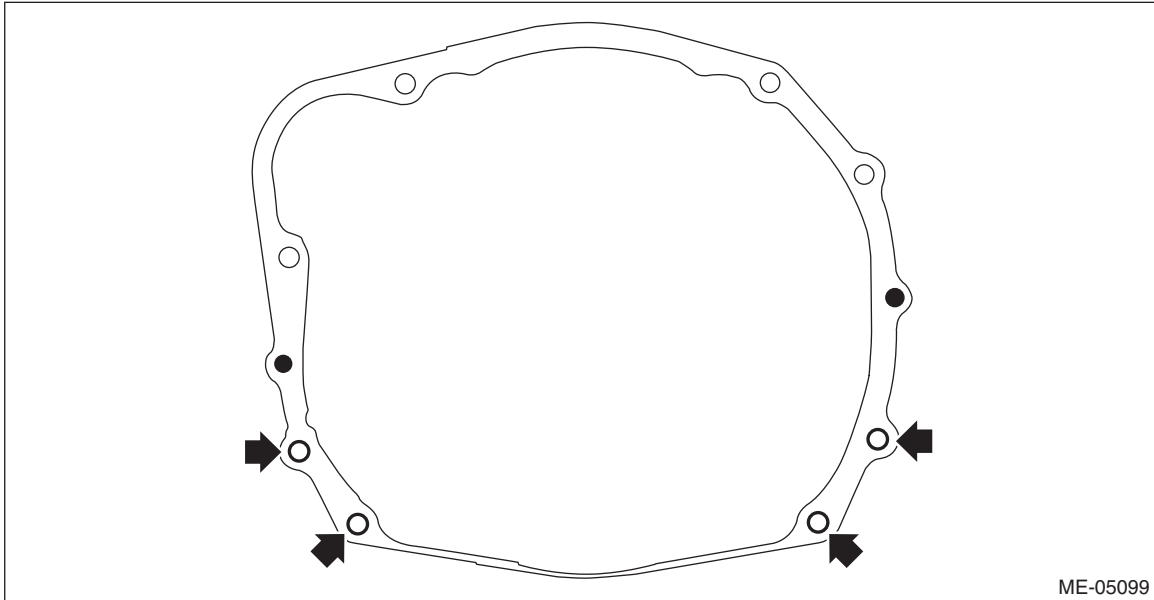

ME-05099

27) Remove the starter. <Ref. to SC(H4DO)-7, REMOVAL, Starter.>

28) Separate the torque converter clutch from the drive plate. (CVT model)

(1) Remove the service hole plug.

(2) Insert the wrench into the crank pulley bolt and rotate the crank pulley to remove the bolts which hold torque converter clutch to drive plate.

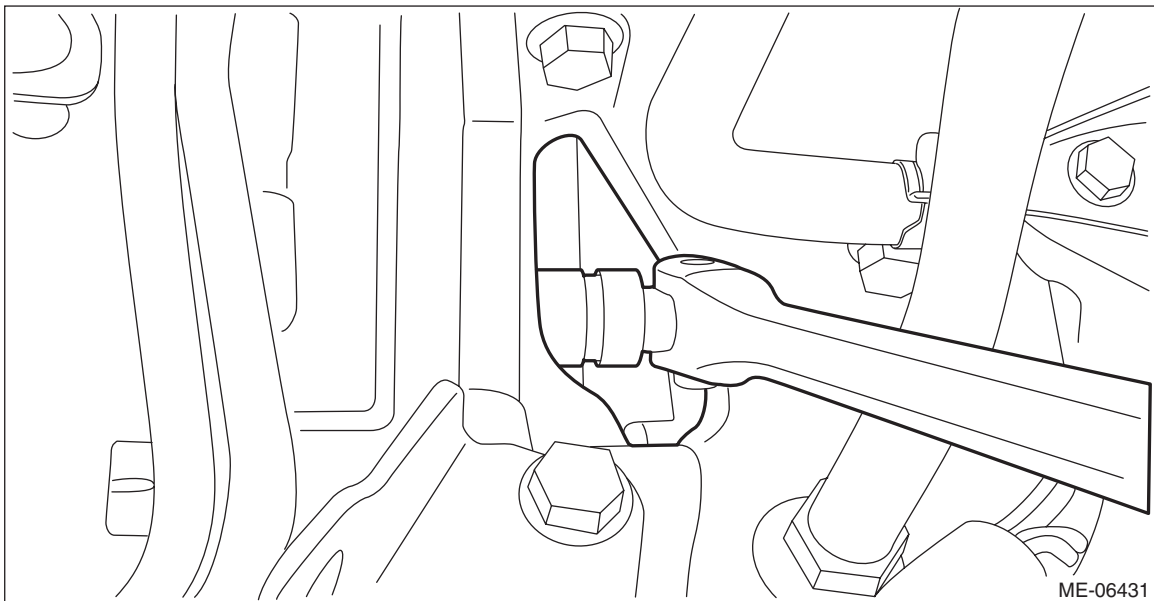

ME-06431

Engine Assembly

MECHANICAL

29) Disconnect the fuel delivery hose and evaporation hose.

CAUTION:

- Be careful not to spill fuel.
- Catch the fuel from hoses using a container or cloth.

(1) Attach ST to the fuel delivery pipe and push ST in the direction of arrow mark to disconnect the quick connector of the fuel delivery hose.

ST 42099AE000 QUICK CONNECTOR RELEASE

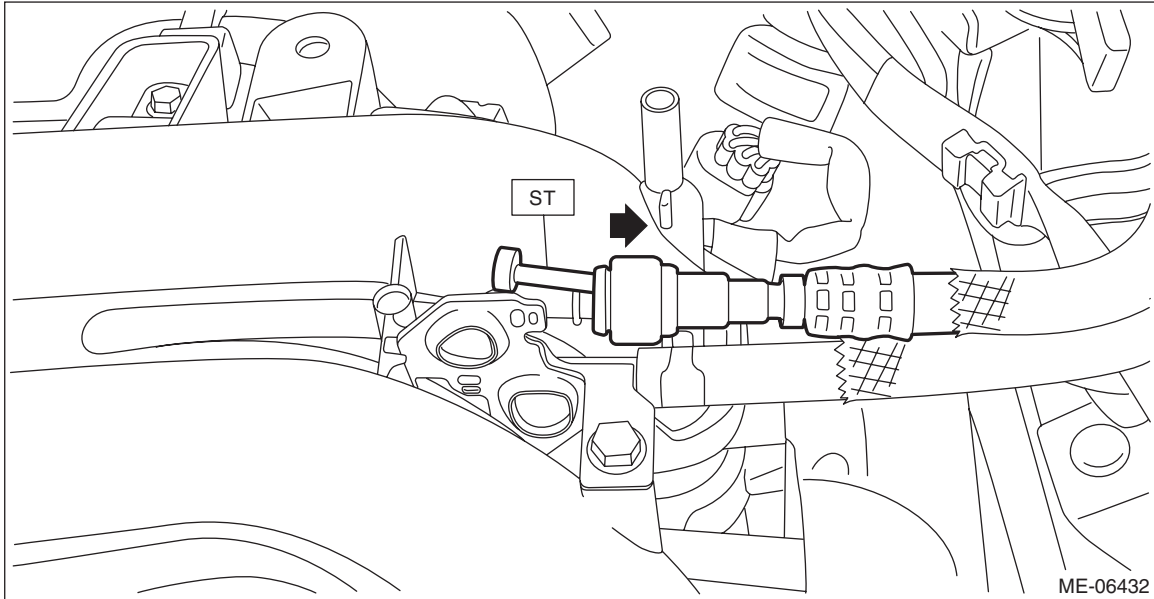

(2) Remove the clip and disconnect the evaporation hose from the evaporation pipe.

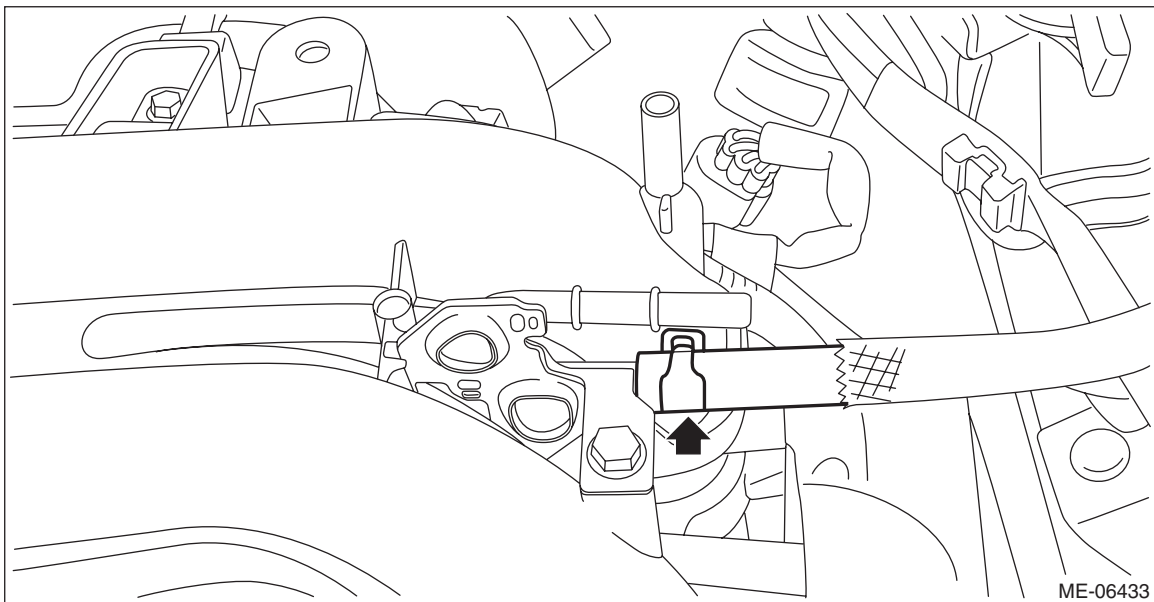

30) Support the engine with a lifting device and wire ropes.

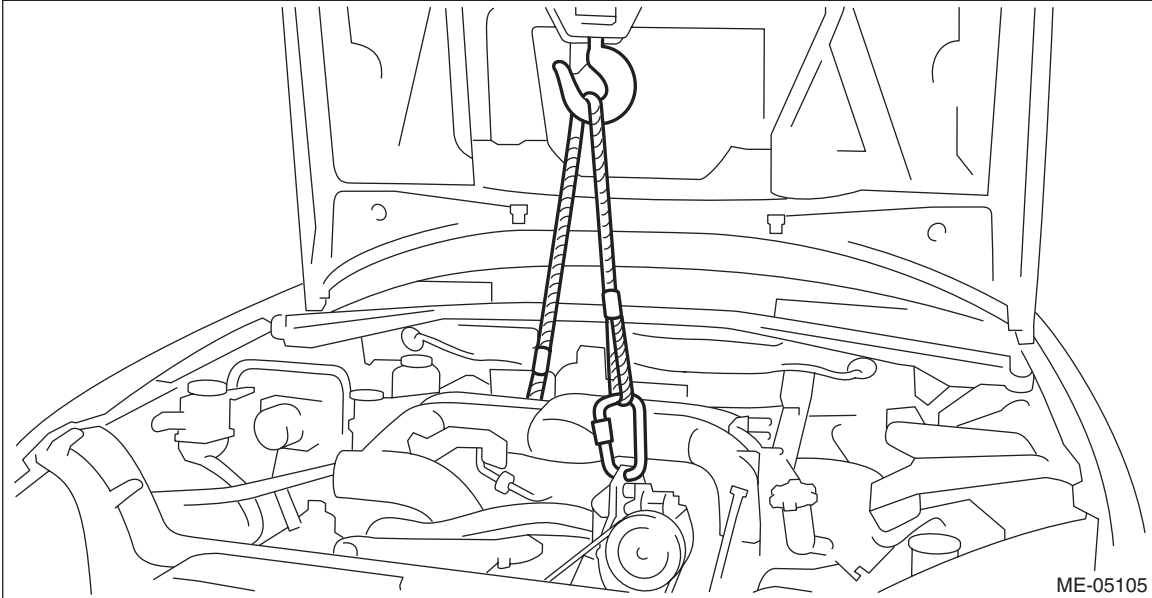

31) Remove the bolt and nut which secure engine mounting to the cradle.

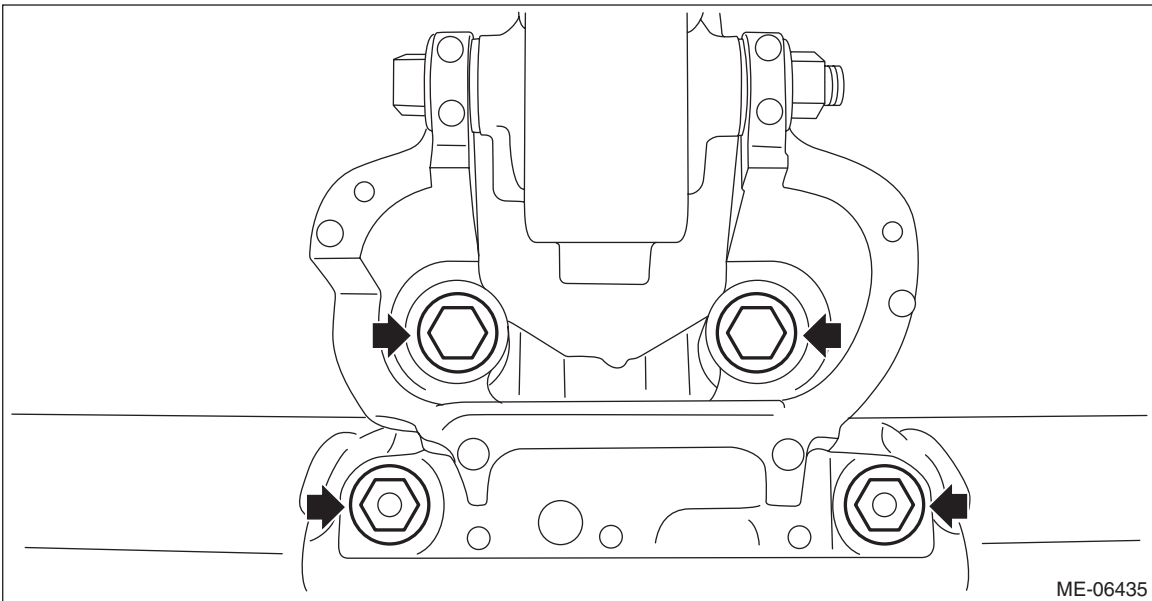

Engine Assembly

MECHANICAL

32) Remove the bolts which secure the engine mounting onto the engine mounting bracket, and remove the engine mounting.

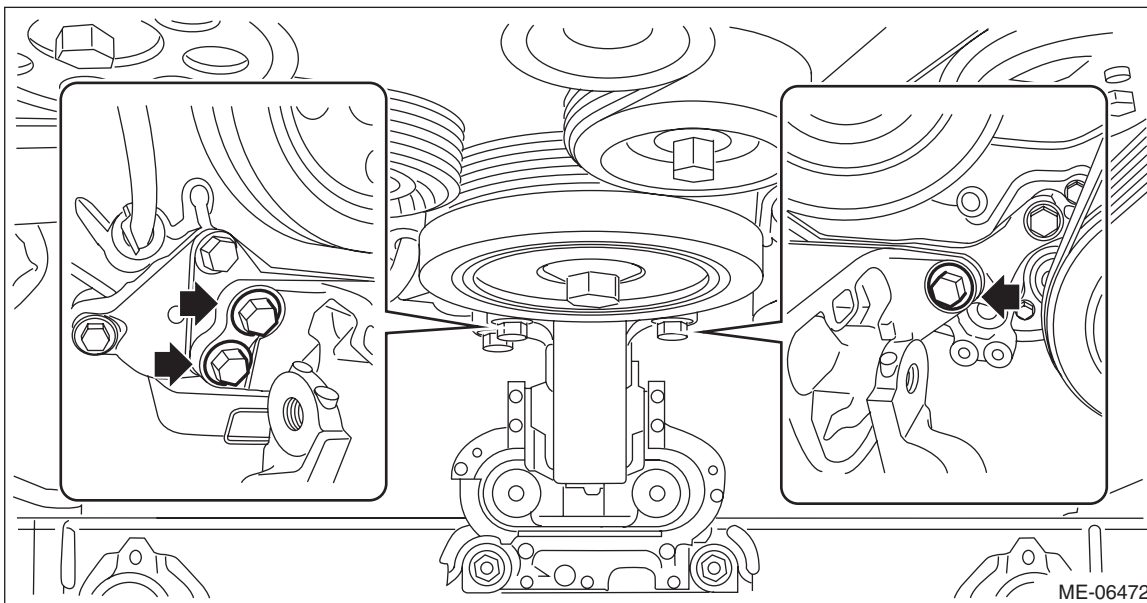

33) Separate the engine and transmission.

CAUTION:

Before removing the engine away from transmission, check to be sure no work has been overlooked.

(1) Remove the starter. <Ref. to SC(H4DO)-7, REMOVAL, Starter.>

(2) Attach the ST to the torque converter clutch case. (CVT model)

ST 498277200 STOPPER SET

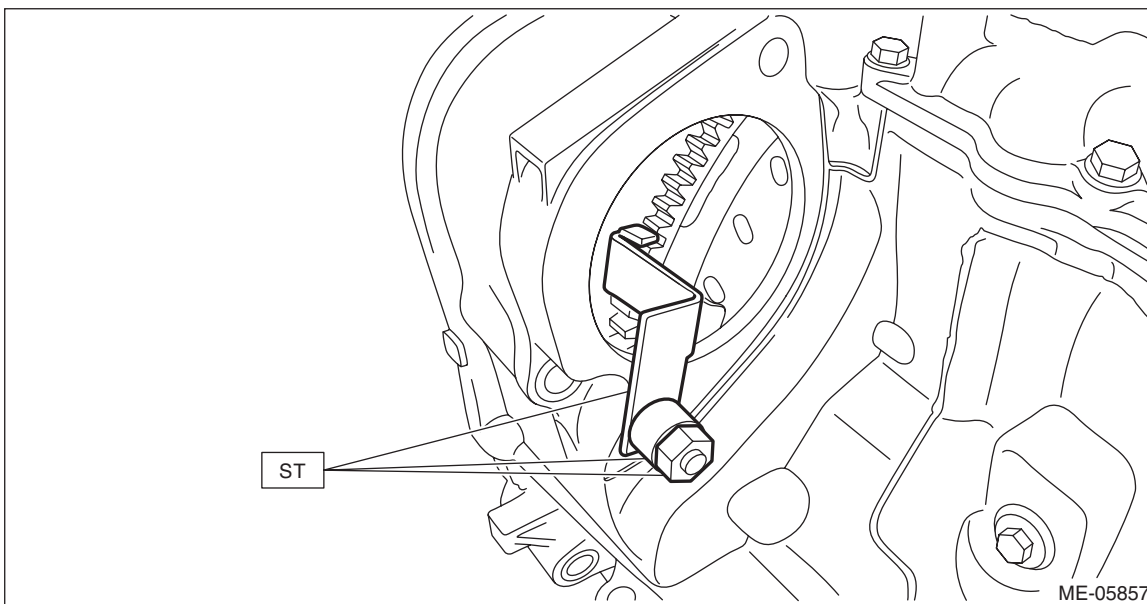

(3) Remove the bolts which hold the upper side of the transmission to the engine.

- CVT model

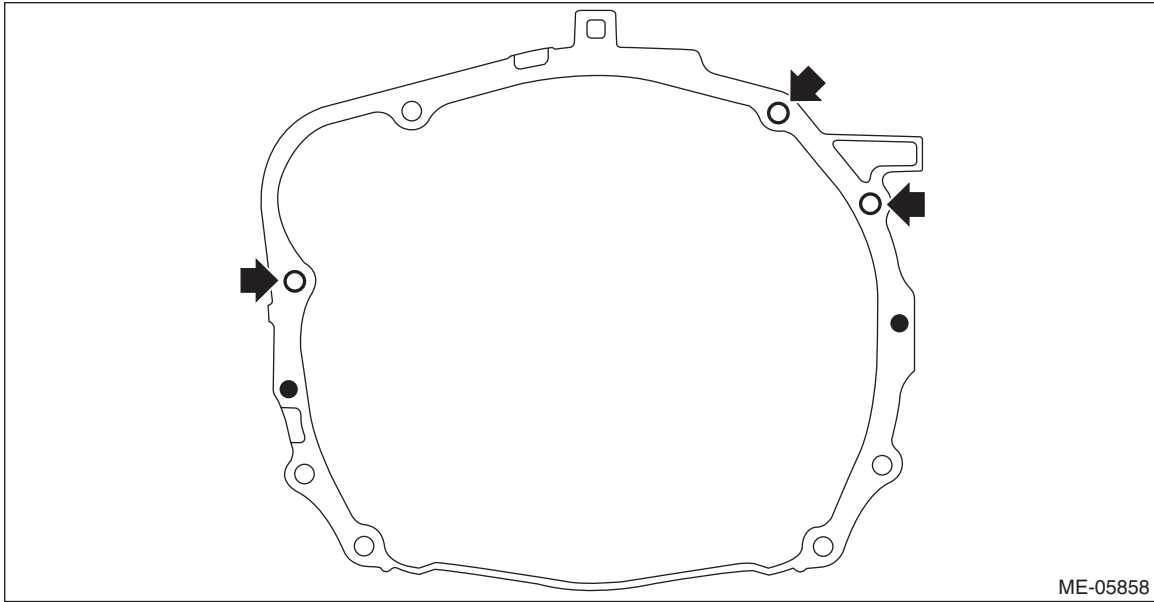

- MT model

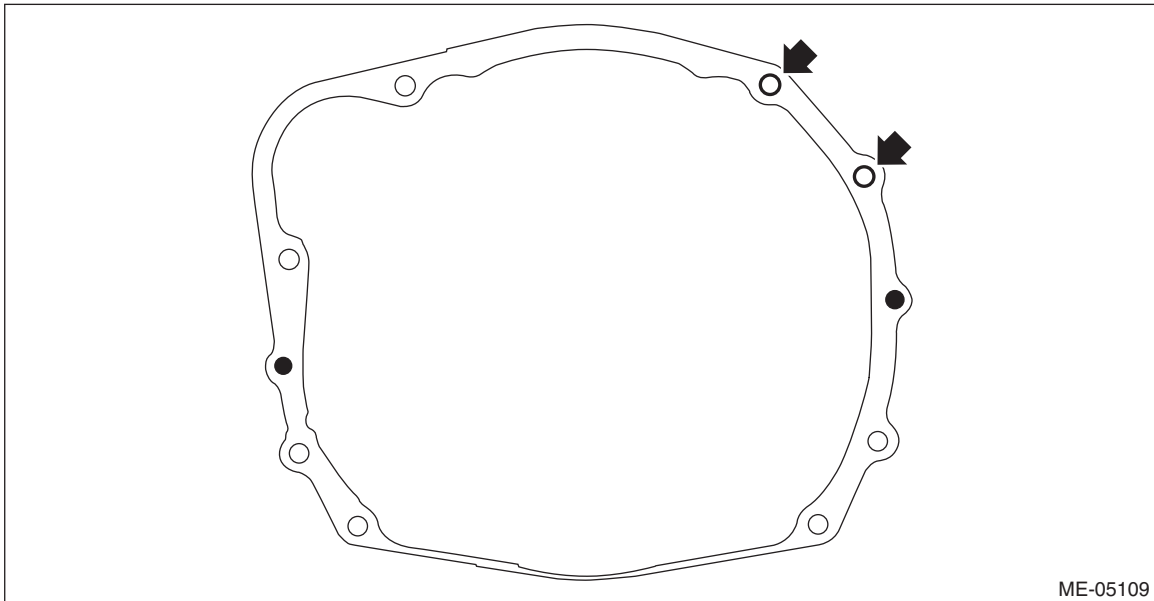

34) Remove the engine from the vehicle.

NOTE:

Be careful not to damage adjacent parts or body panels with crank pulley, oil level gauge, etc.

- (1) Slightly raise the engine.
- (2) Move the engine horizontally until main shaft is withdrawn from clutch cover. (MT model)
- (3) Slowly move the engine away from engine compartment.

Engine Assembly

MECHANICAL

35) Remove the engine mounting bracket from the engine.

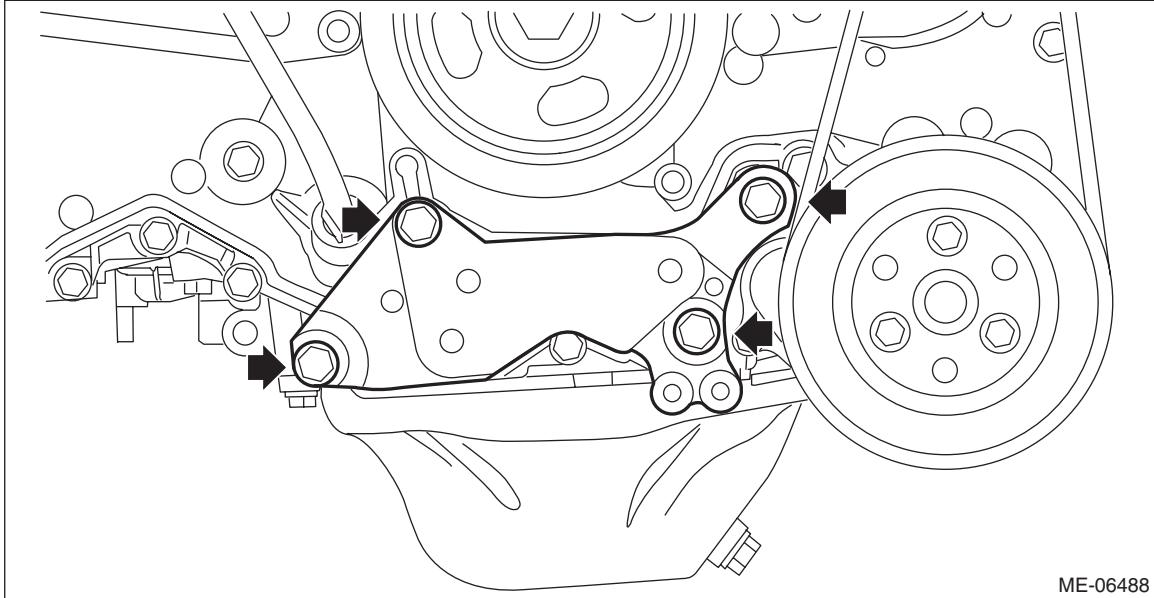

B: INSTALLATION

1) Install the engine mounting bracket onto the engine.

Tightening torque:

30 N·m (3.1 kgf·m, 22.1 ft·lb)

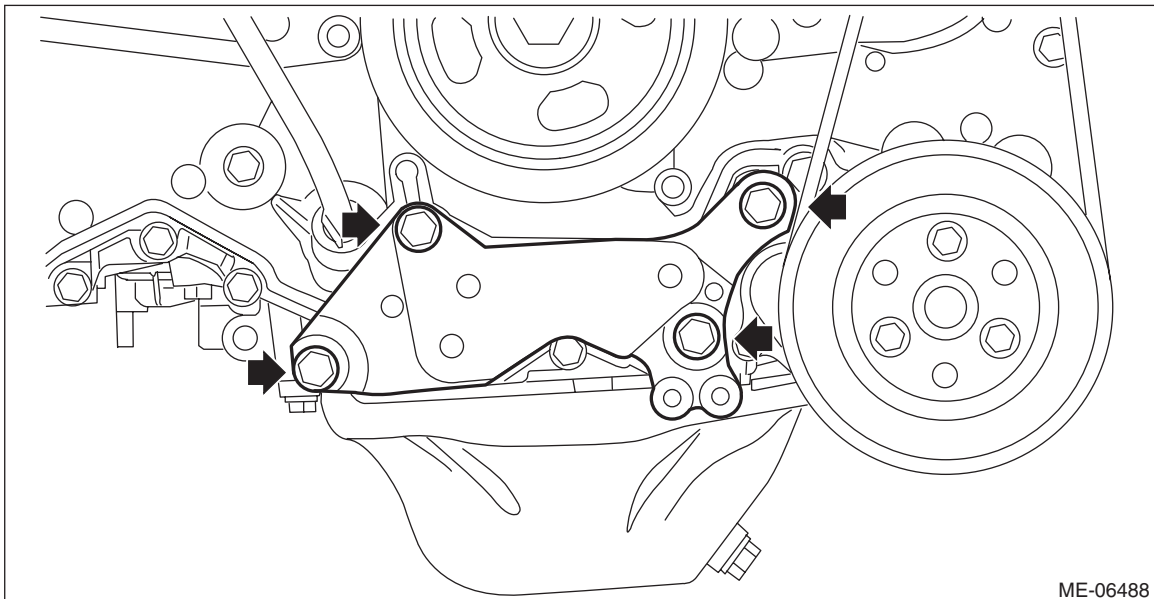

2) Apply a small amount of grease to splines of main shaft. (MT model)

Grease:

NICHIMOLY N-130 or equivalent

3) Position the engine in engine compartment and align it with transmission.

NOTE:

Be careful not to damage adjacent parts or body panels with crank pulley, oil level gauge, etc.

4) Install the bolts which hold upper side of transmission to engine.

Tightening torque:

50 N·m (5.1 kgf-m, 36.9 ft-lb)

- CVT model

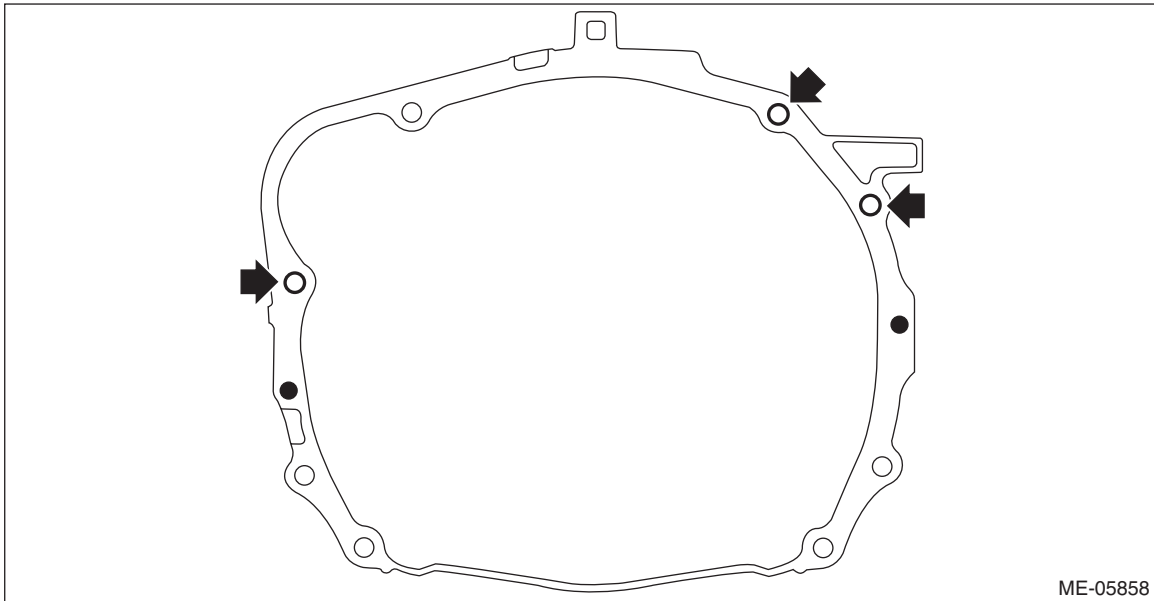

ME-05858

- MT model

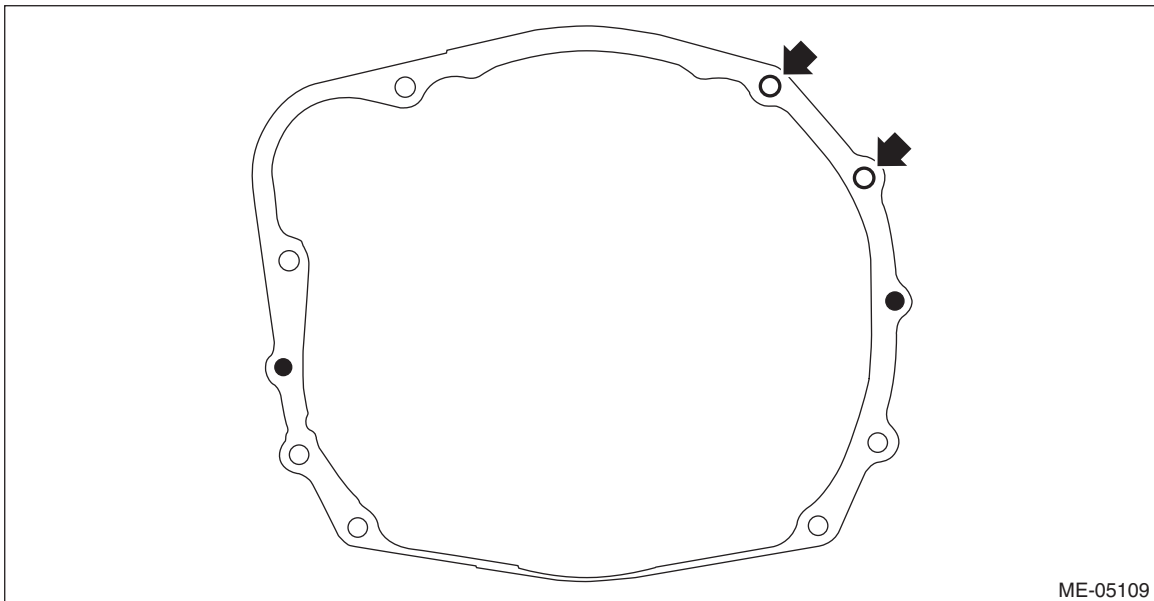

ME-05109

Engine Assembly

MECHANICAL

5) Attach the bolts which secure the engine mounting to the engine mounting bracket.

Tightening torque:

25 N·m (2.5 kgf·m, 18.4 ft·lb)

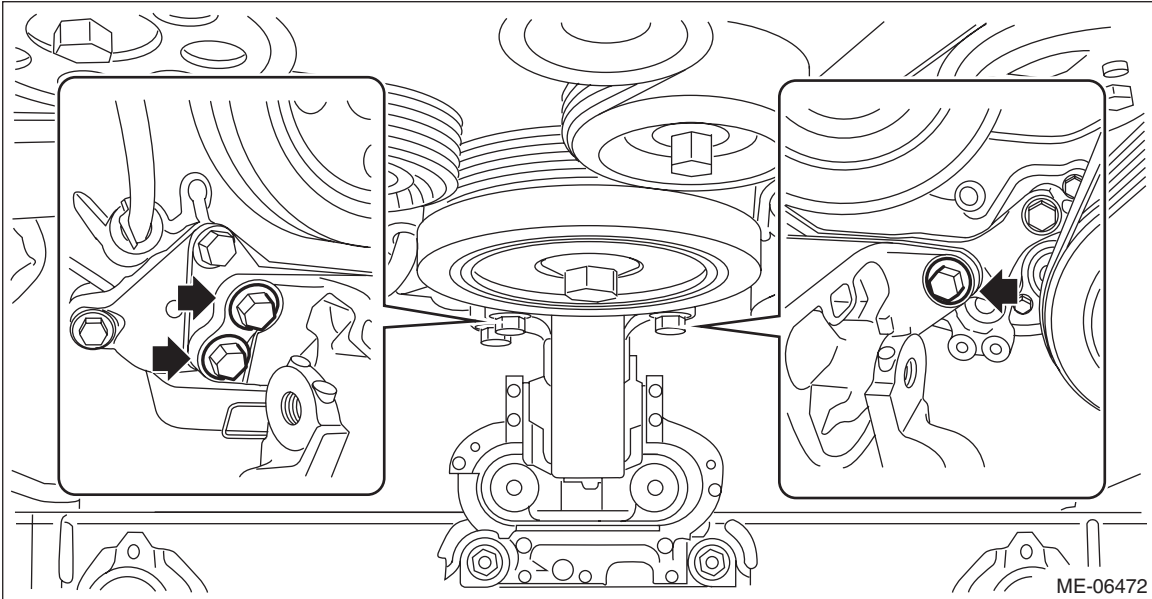

6) Attach the bolts and nuts which secure engine mounting to the cradle.

Tightening torque:

60 N·m (6.1 kgf·m, 44.3 ft·lb)

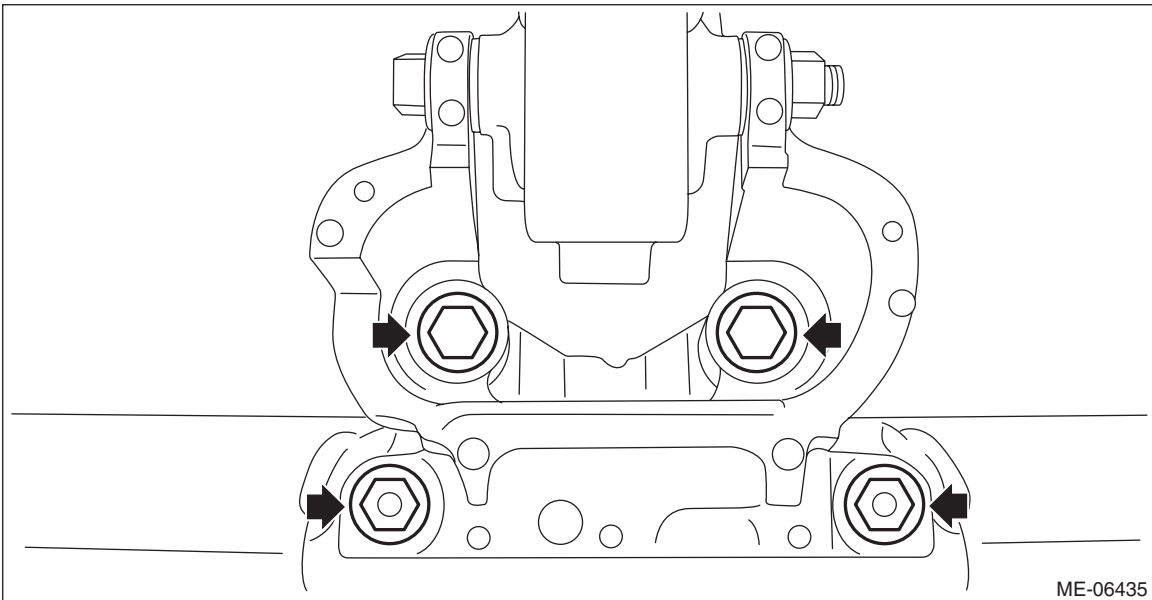

7) Remove the lifting device and wire ropes.

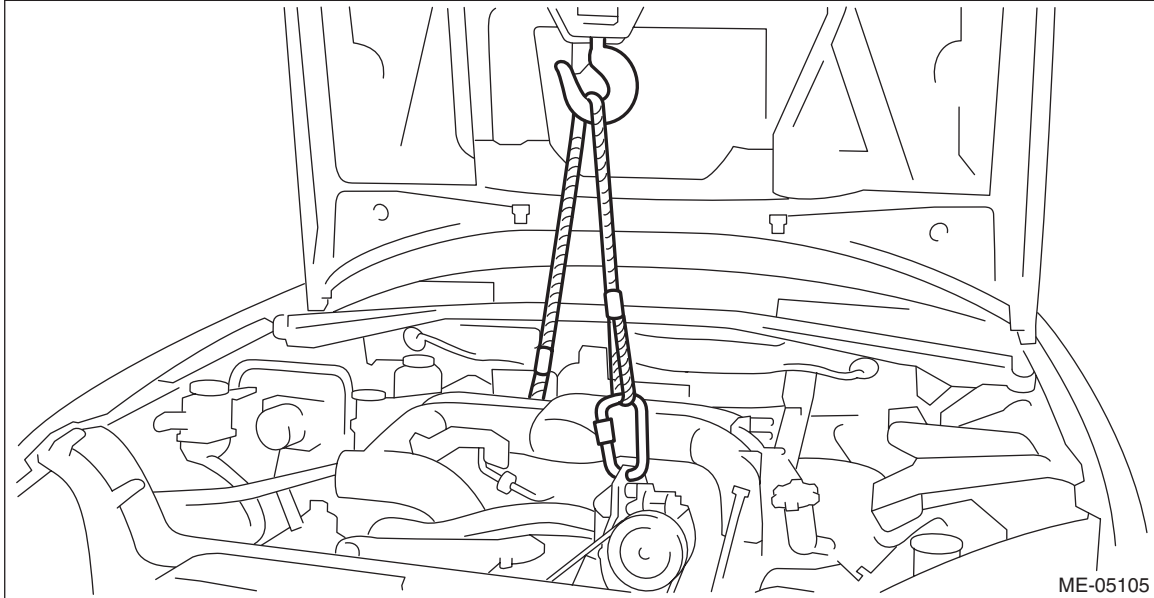

8) Remove the ST from torque converter clutch case. (CVT model)

NOTE:

Be careful not to drop the ST into the torque converter clutch case when removing the ST.

ST 498277200 STOPPER SET

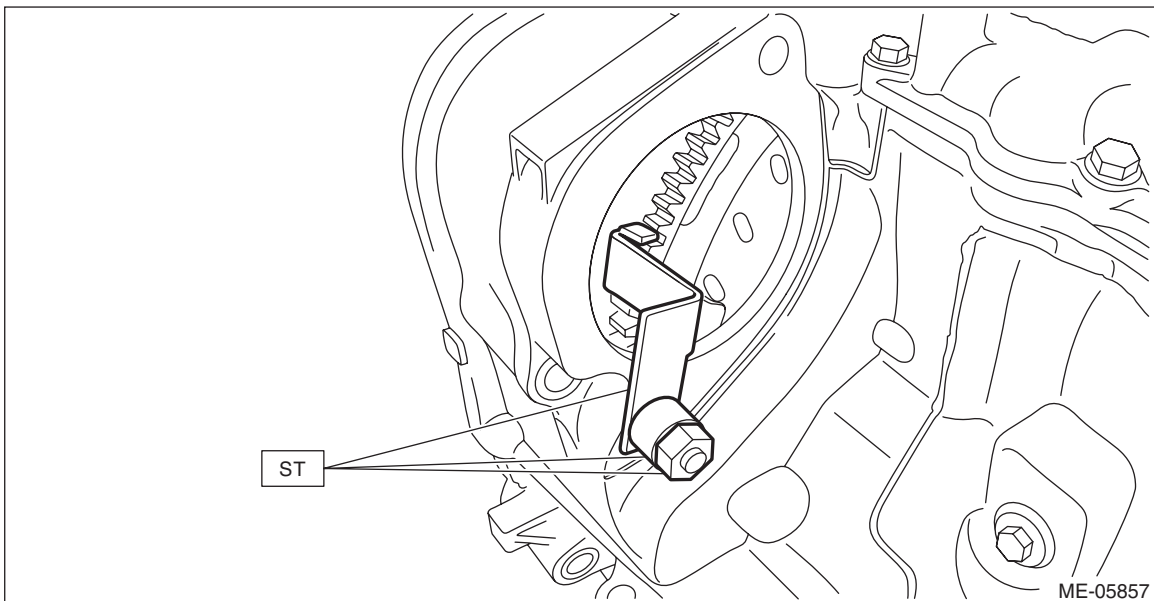

Engine Assembly

MECHANICAL

9) Install the torque converter clutch to drive plate. (CVT model)

(1) Insert the wrench into the crank pulley bolt and rotate the crank pulley to install the bolts which hold torque converter clutch to drive plate.

NOTE:

Be careful not to drop bolts into the torque converter clutch case.

Tightening torque:

25 N·m (2.5 kgf·m, 18.4 ft·lb)

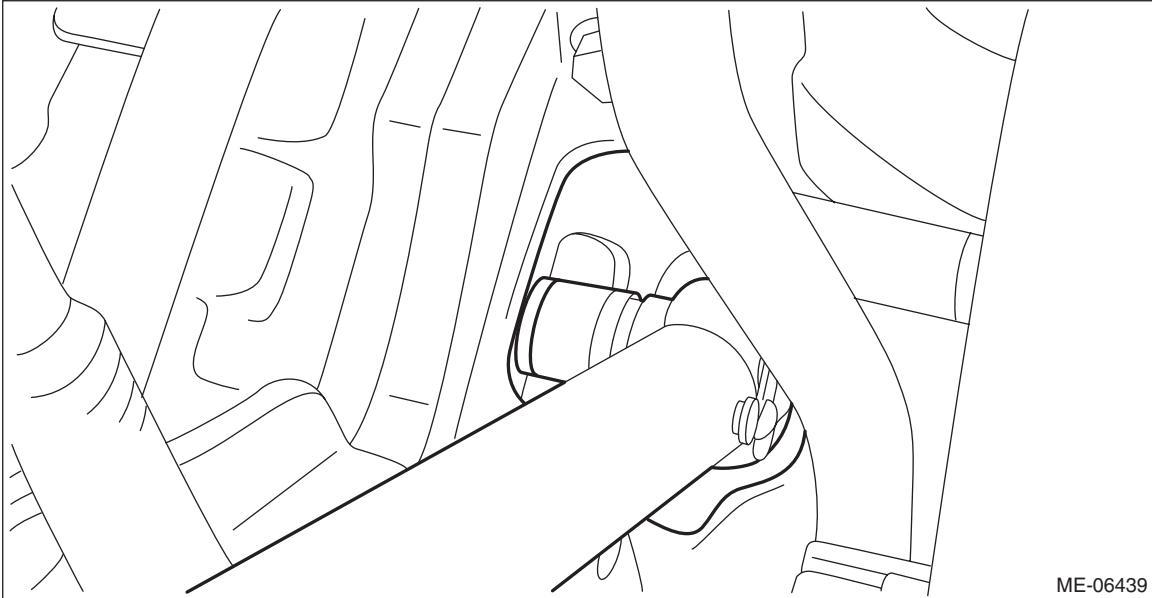

(2) Fit the plug to service hole.

10) Install the starter. <Ref. to SC(H4DO)-10, INSTALLATION, Starter.>

11) Lift up the vehicle.

12) Install the bolts and nuts which hold lower side of the transmission to engine.

Tightening torque:

50 N·m (5.1 kgf·m, 36.9 ft·lb)

- CVT model

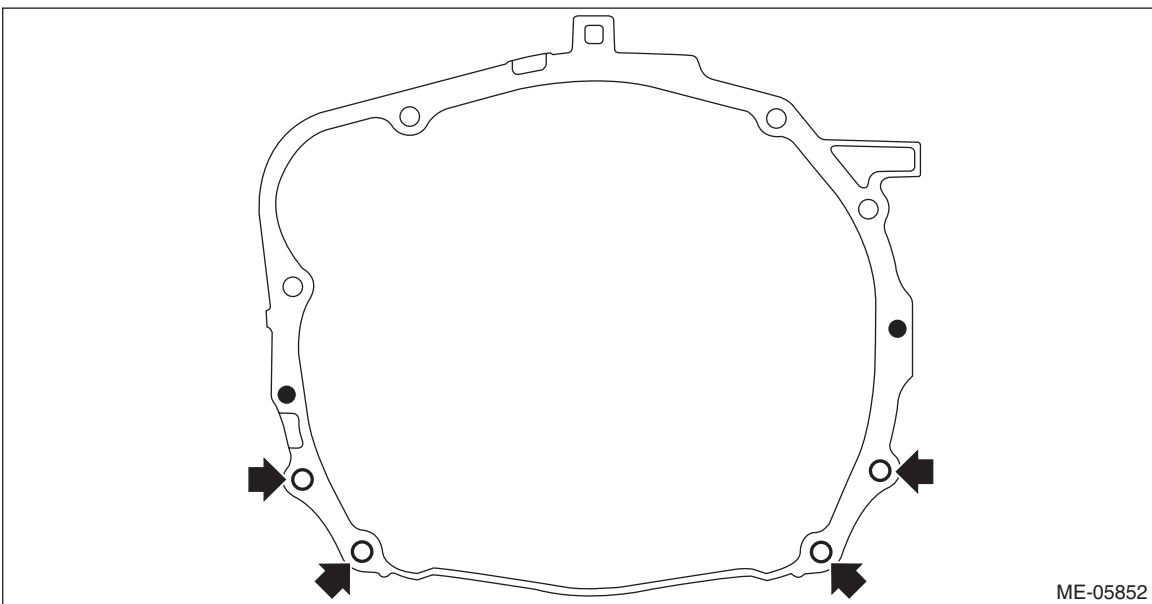

- MT model

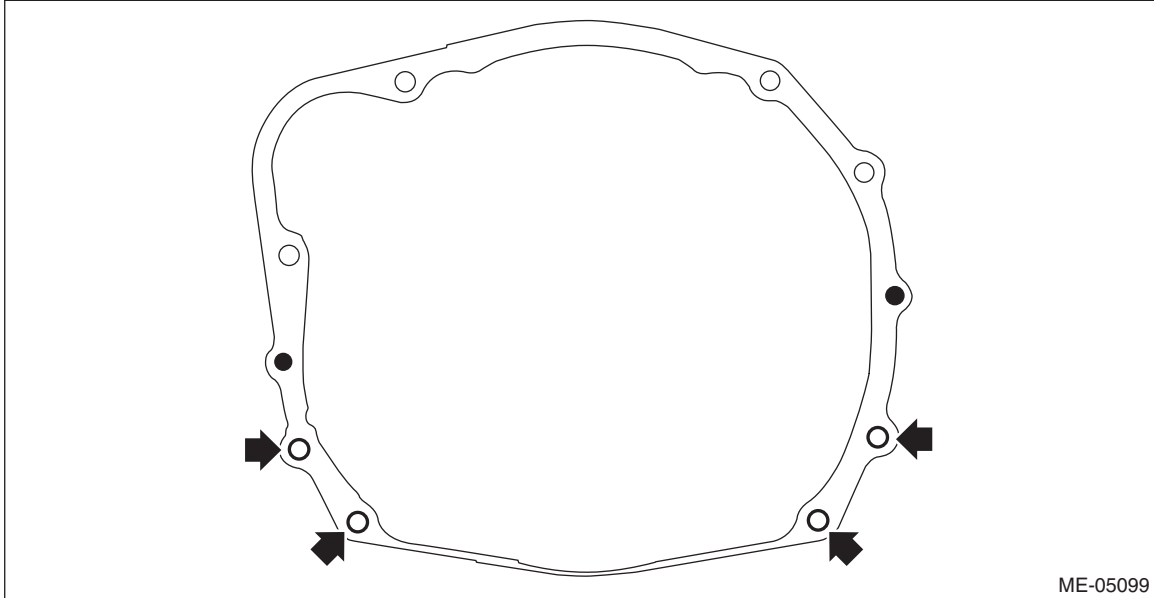

13) Connect the ground cable.

Tightening torque:
7.5 N·m (0.8 kgf-m, 5.5 ft-lb)

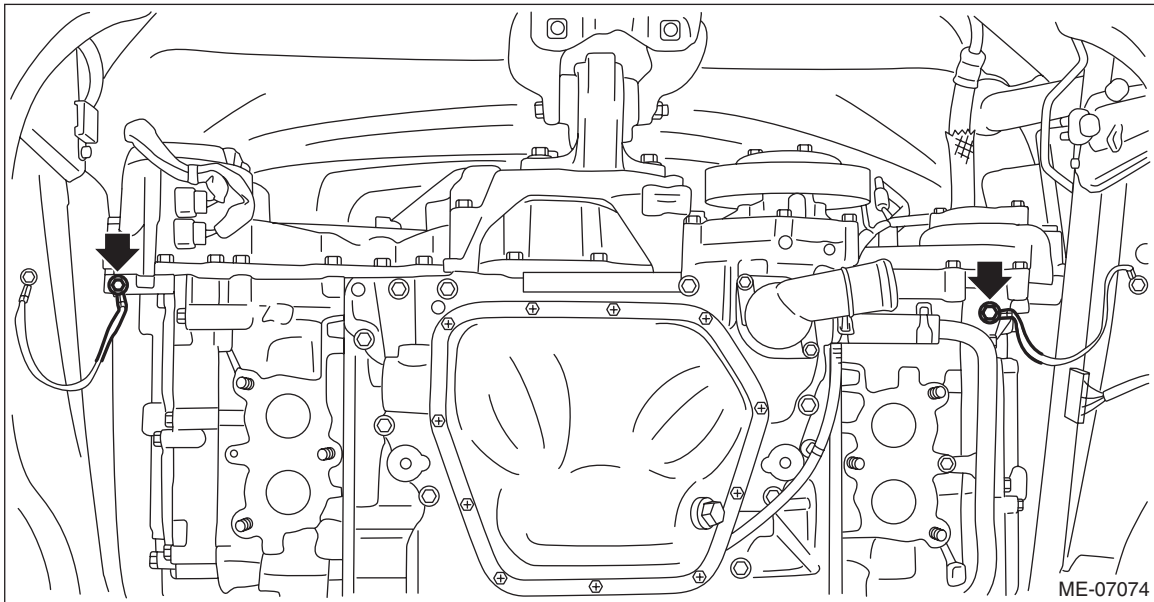

14) Install the front exhaust pipe. <Ref. to EX(H4DO)-8, INSTALLATION, Front Exhaust Pipe.>

15) Lower the vehicle.

Engine Assembly

MECHANICAL

16) Connect the following hoses.

- (1) Fuel delivery hose and evaporation hose <Ref. to FU(H4DO)-169, EVAPORATION HOSE CONNECTION, INSTALLATION, Fuel Delivery and Evaporation Lines.>
- (2) Heater inlet hose and heater outlet hose

NOTE:

Be careful not to mix up the heater inlet hose and the heater outlet hose when connecting them.

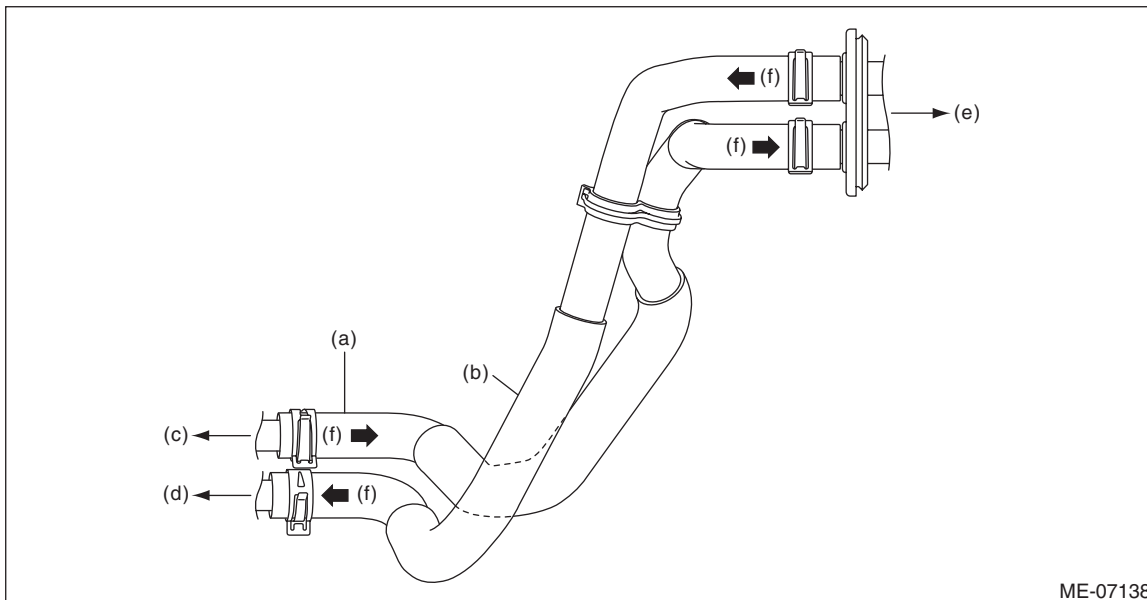

- | | | |
|------------------------|------------------------|-------------------------|
| (a) Heater inlet hose | (c) To water pipe ASSY | (e) To heater core ASSY |
| (b) Heater outlet hose | (d) To water pipe LH | (f) Engine coolant flow |

(3) Brake booster vacuum hose

(4) A/C pressure hose <Ref. to AC-76, INSTALLATION, Hose and Pipe.>

17) Install the power steering pump.

- (1) Install the power steering pump together with the power steering pump bracket onto the engine.

Tightening torque:

Refer to "COMPONENT" of "STARTING/CHARGING SYSTEMS" for the tightening torque. <Ref. to SC(H4DO)-5, GENERATOR BRACKET, COMPONENT, General Description.>

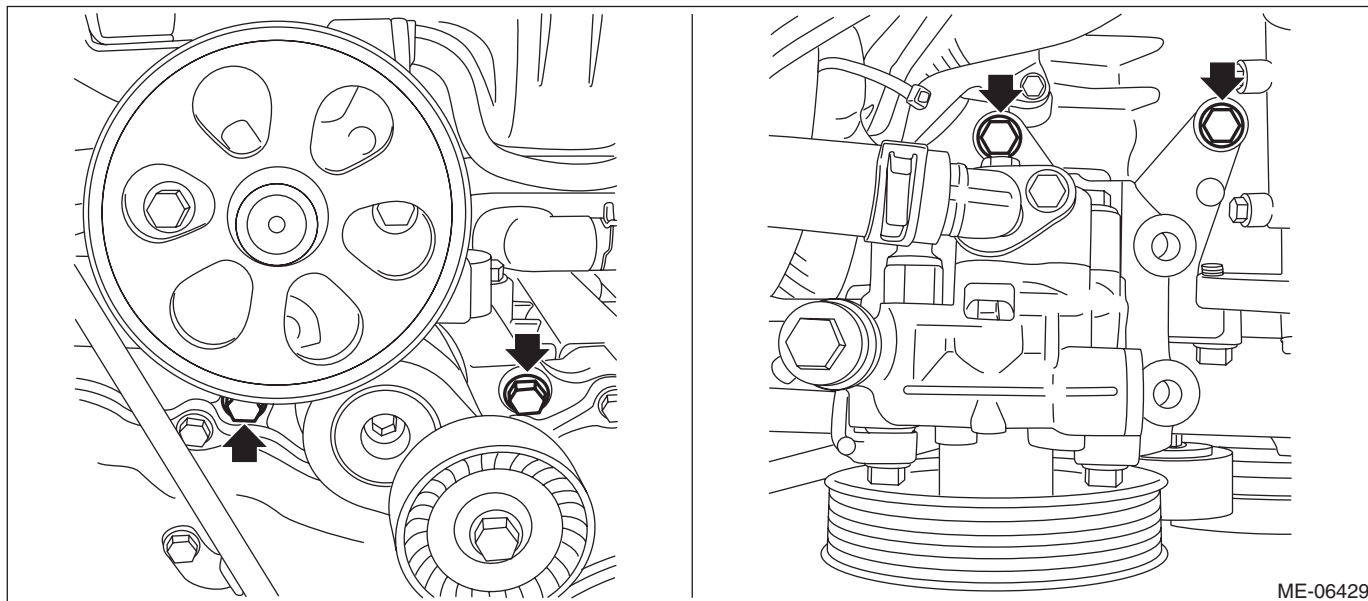

(2) Connect the connector to the power steering pump.

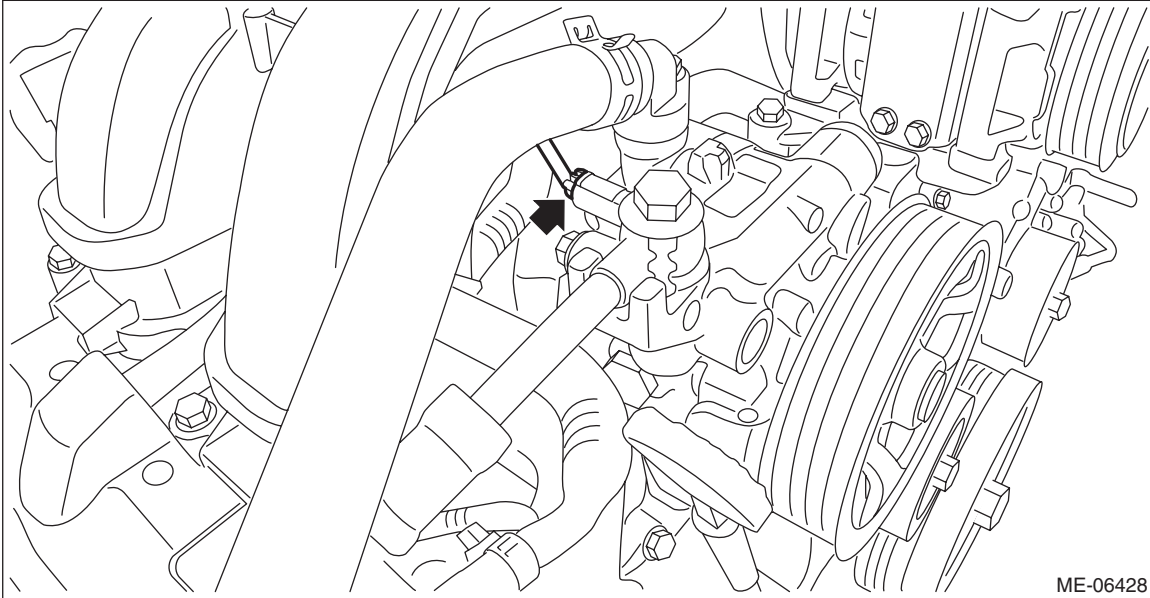

(3) Install the generator. <Ref. to SC(H4DO)-32, INSTALLATION, Generator.>

(4) Install the V-belts. <Ref. to ME(H4DO)-82, INSTALLATION, V-belt.>

18) Place the generator code and install the generator cord to the clip (D).

19) Connect connector (A) and terminal (B) to the generator, and secure them to the stay of the A/C compressor with the clip (C).

Tightening torque:

15 N·m (1.5 kgf·m, 11.1 ft·lb)

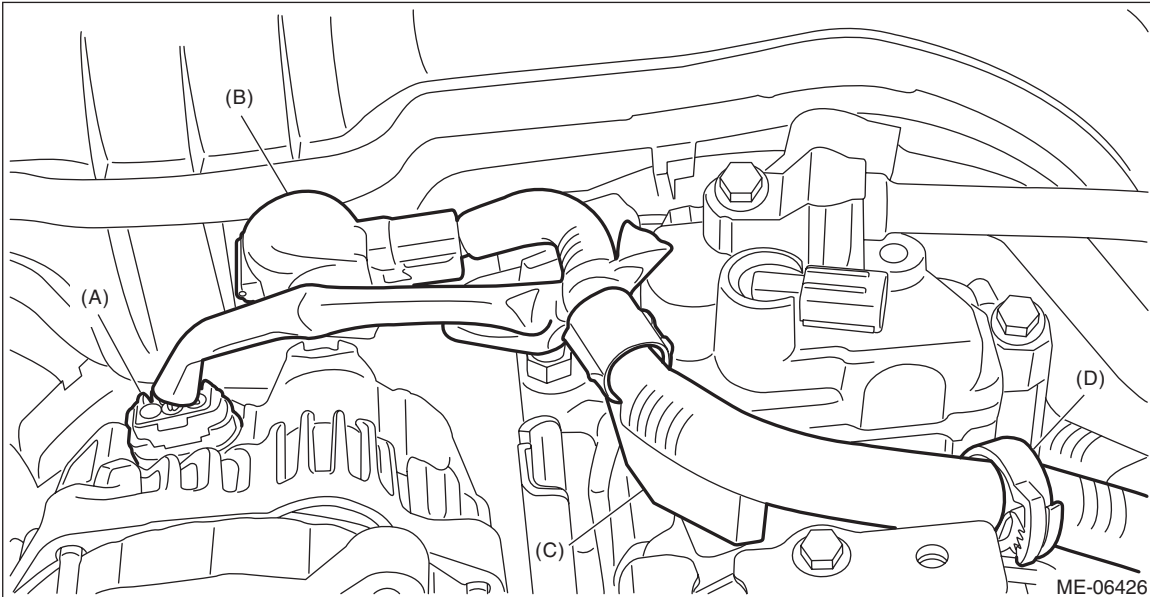

Engine Assembly

MECHANICAL

20) Connect the connectors (A) and (B) to the A/C compressor.

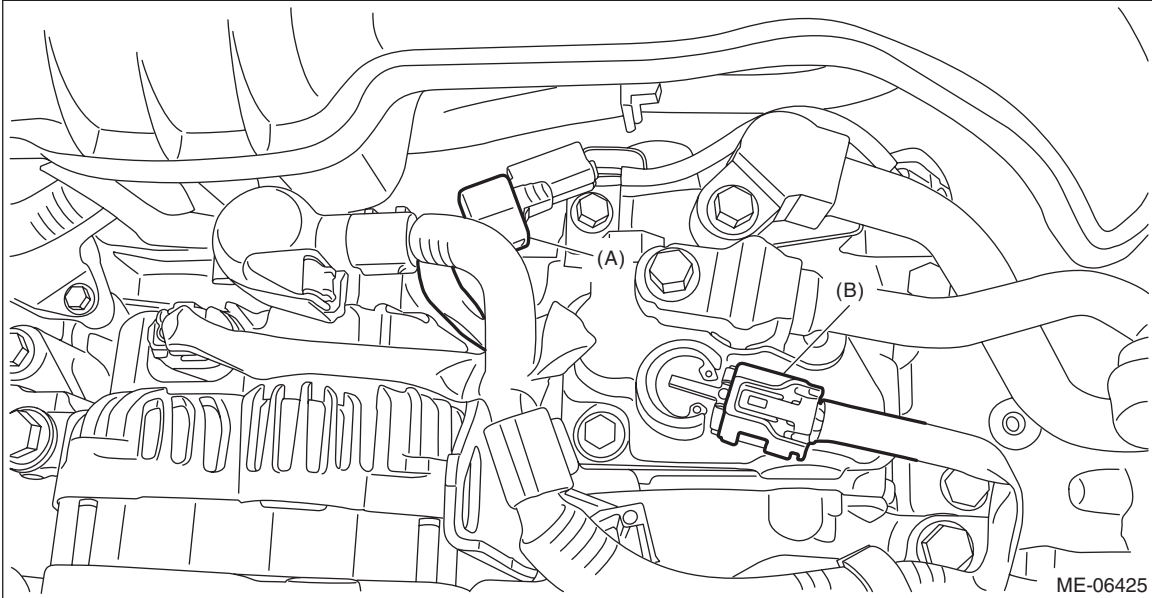

21) Install the generator cord stay to the chain cover.

NOTE:

Install the generator cord stay so that the folded end (A) touches at the chain cover boss.

Tightening torque:

6.4 N·m (0.7 kgf-m, 4.7 ft-lb)

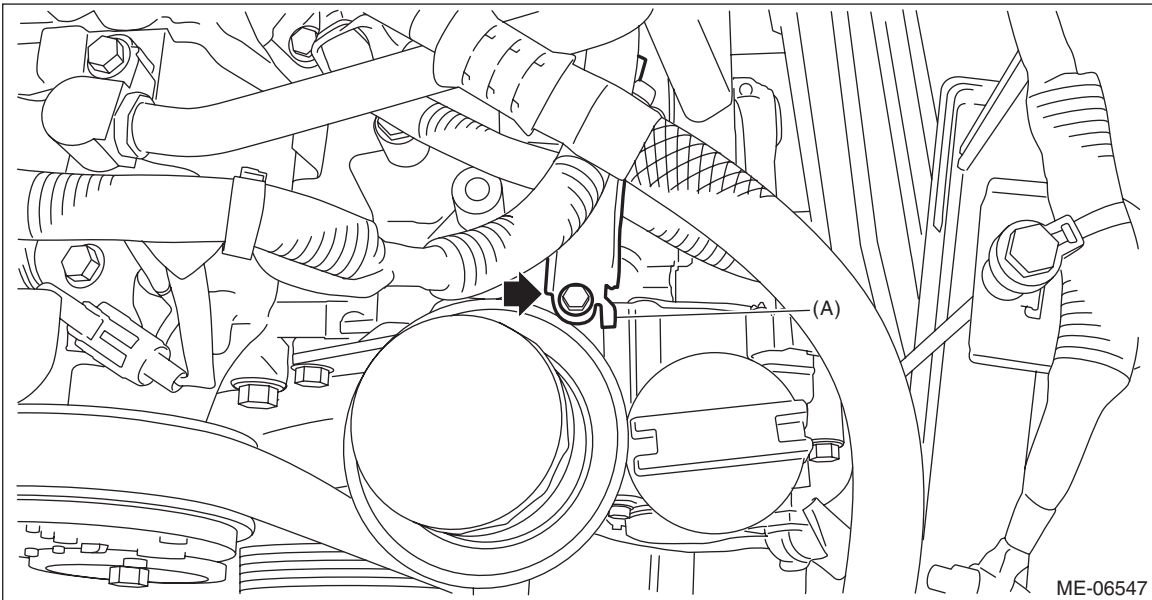

22) Connect the engine harness connector.

(1) Connect the bulkhead harness connector to the engine harness connector (black) and engine harness connector (brown).

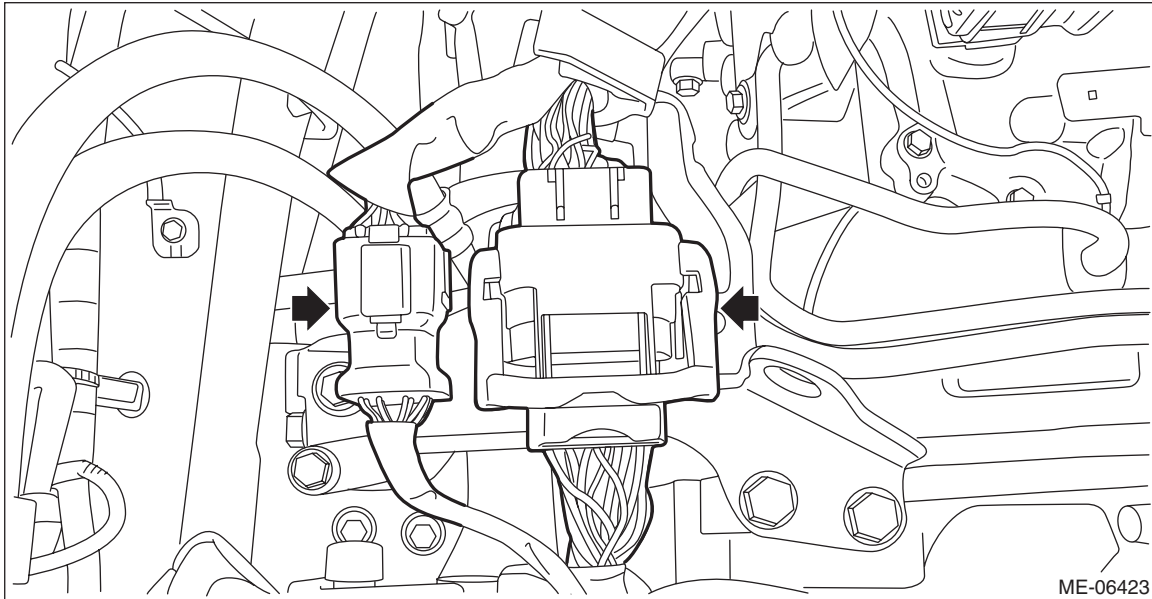

(2) Install the bolt which secures the bulkhead harness connector bracket.

Tightening torque:

7.5 N·m (0.8 kgf-m, 5.5 ft-lb)

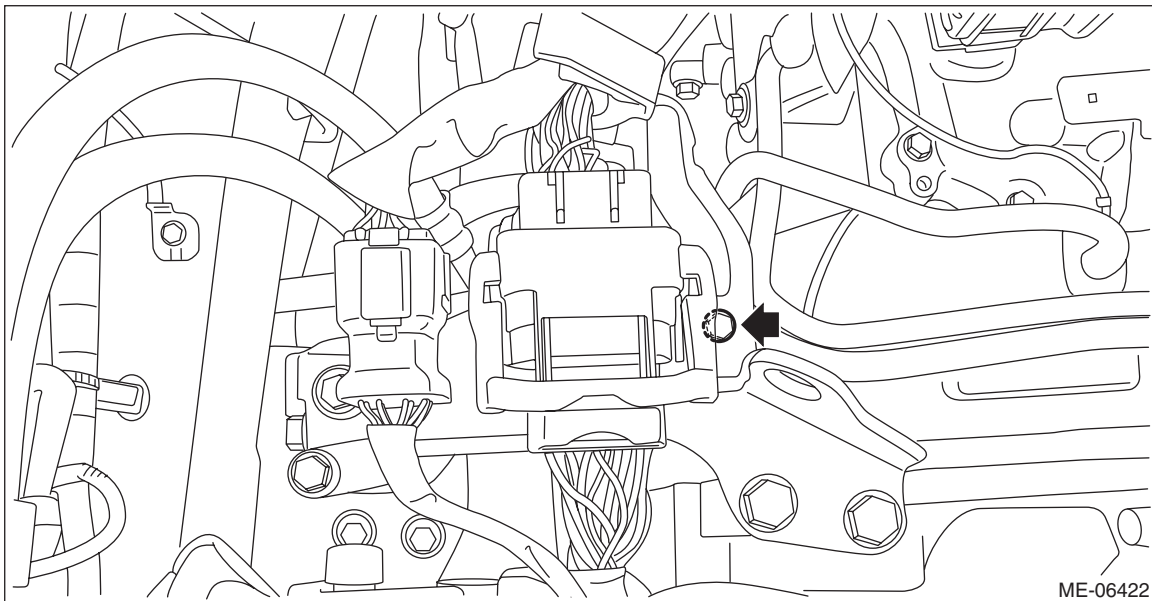

23) Install the radiator. <Ref. to CO(H4DO)-29, INSTALLATION, Radiator.>

Engine Assembly

MECHANICAL

24) Install the air intake case (rear).

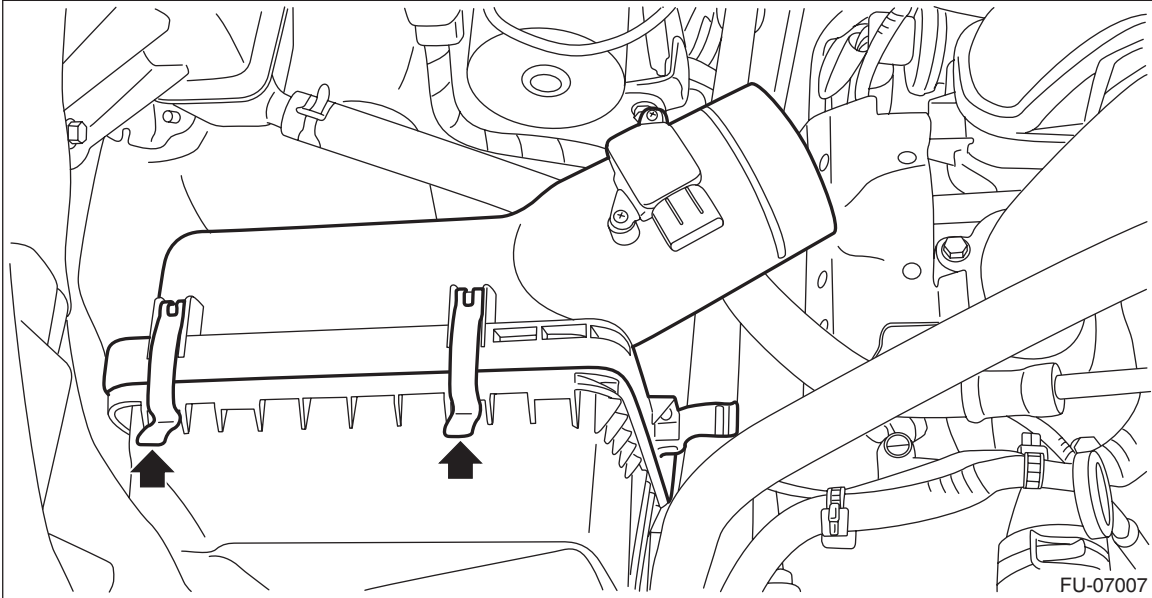

25) Install the suction hose (C) to the air cleaner case.

26) Install the clip (B) which secures the air flow and intake air temperature sensor harness, and connect the connector (A) to the air flow and intake air temperature sensor.

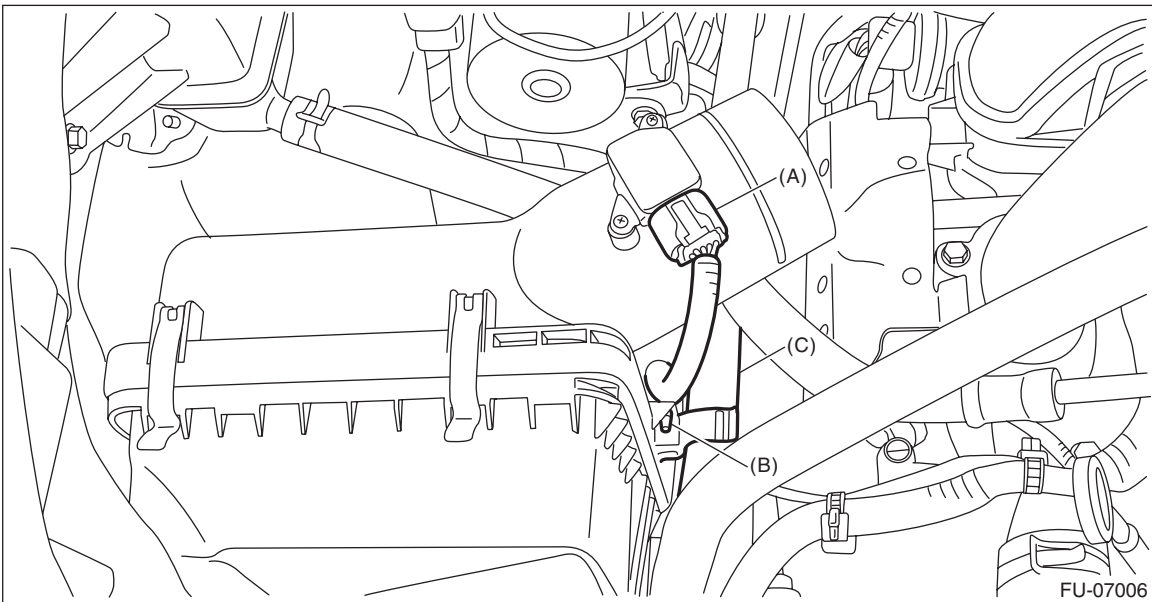

27) Install the air intake boot. <Ref. to IN(H4DO)-13, INSTALLATION, Air Intake Boot.>

28) Install the air intake duct. <Ref. to IN(H4DO)-14, INSTALLATION, Air Intake Duct.>

29) Connect the battery ground terminal.

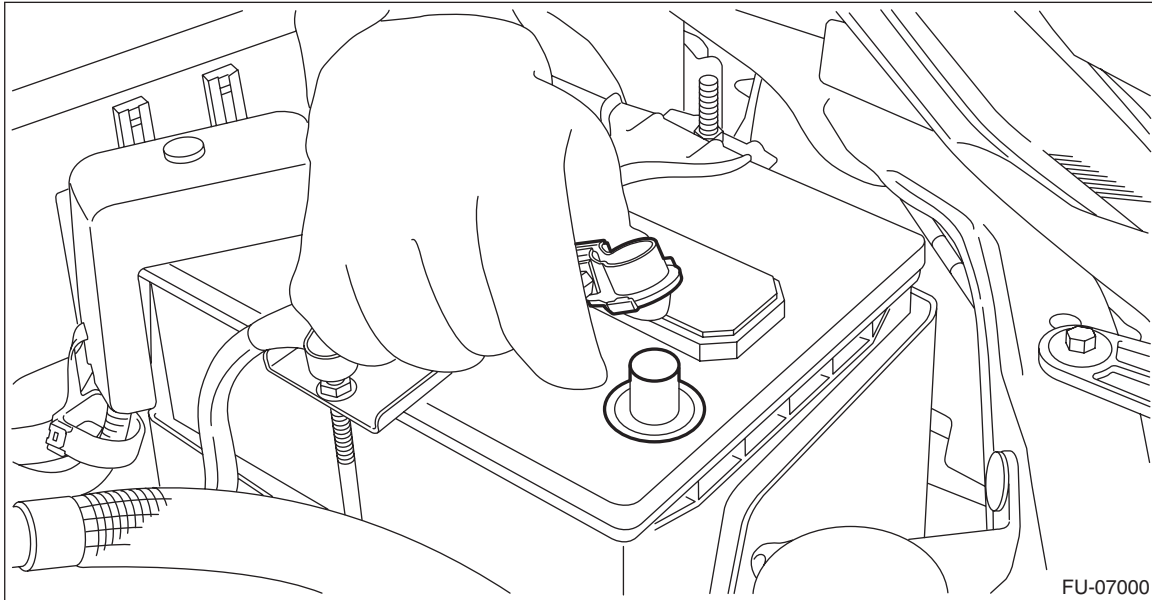

30) Fill engine coolant. <Ref. to CO(H4DO)-15, FILLING OF ENGINE COOLANT, REPLACEMENT, Engine Coolant.>

31) Check the CVTF level and replenish it if necessary. (CVT model)<Ref. to CVT-36, ADJUSTMENT, CVTF.>

32) Charge the A/C system with refrigerant. <Ref. to AC-27, PROCEDURE, Refrigerant Charging Procedure.>

33) Install the V-belt cover.

Tightening torque:

6.4 N·m (0.7 kgf·m, 4.7 ft·lb)

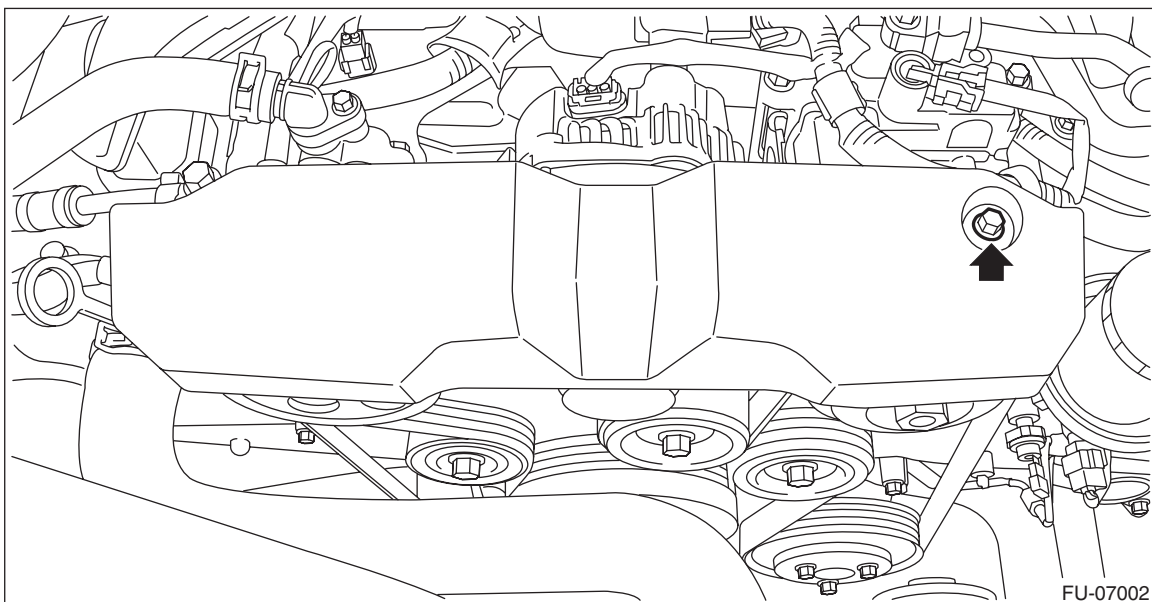

Engine Assembly

MECHANICAL

34) Change the front hood damper mounting position from (B) to (A), and close the front hood.

Tightening torque:

20 N·m (2.0 kgf·m, 14.8 ft·lb)

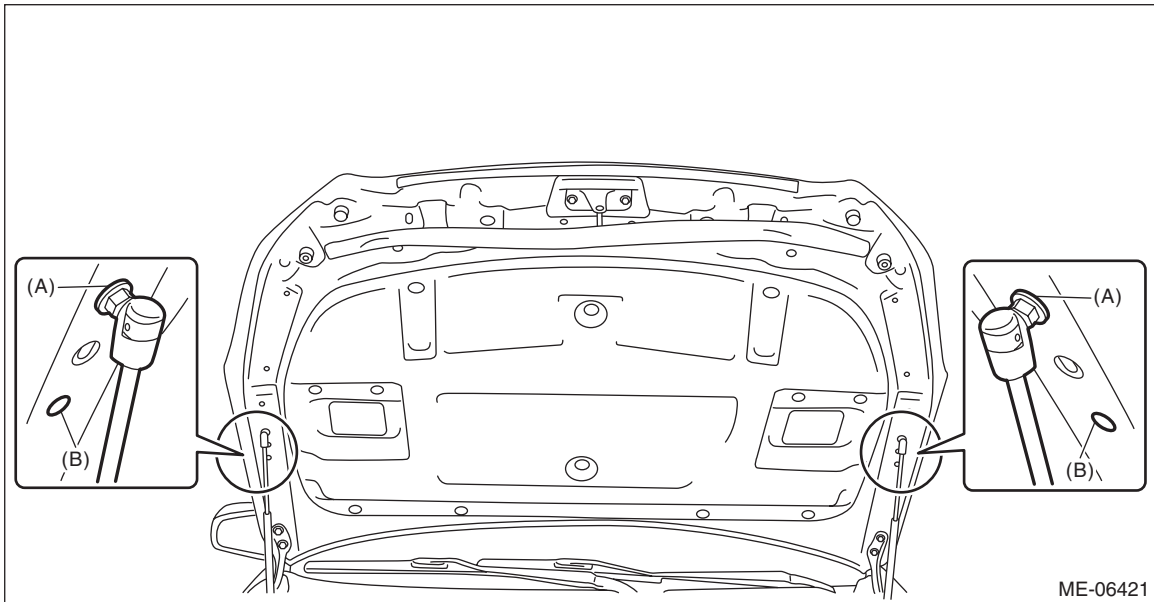

C: INSPECTION

- 1) Check that pipes, hoses, connectors and clamps are installed firmly.
- 2) Check the engine coolant is at specified level.
- 3) Check CVTF is at the specified level. (CVT model)
- 4) Start the engine and check for exhaust gas, engine coolant, leaks of fuel, etc. Also check for noise and vibrations.