

Accelerator Pedal

SPEED CONTROL SYSTEMS

2. Accelerator Pedal

A: REMOVAL

- 1) Disconnect the ground cable from battery.

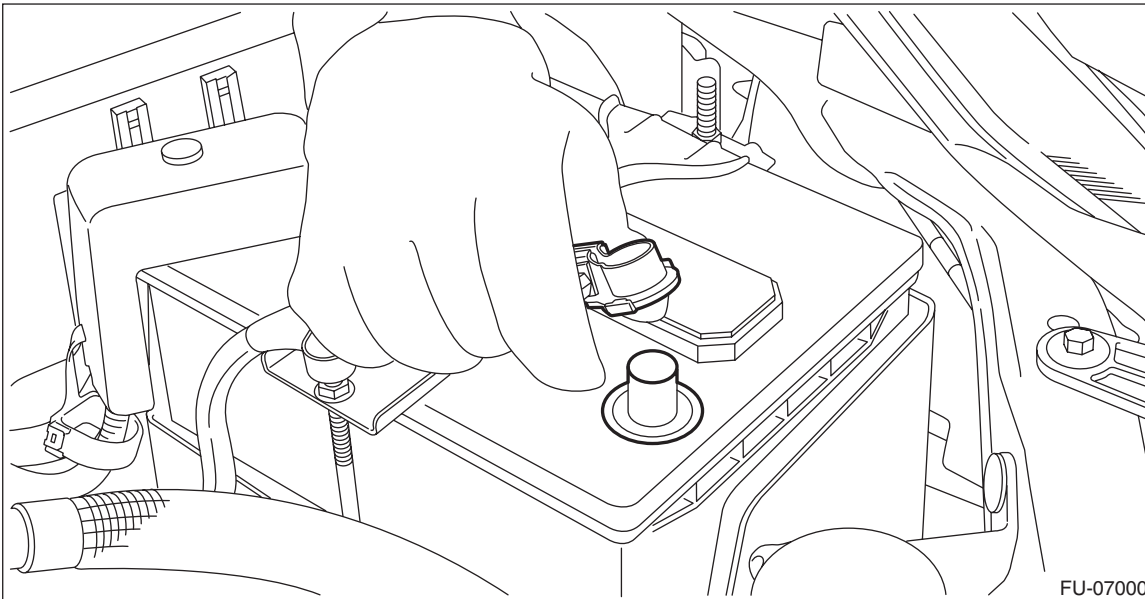

- 2) Disconnect the connector (A).
- 3) Remove the nut (B) securing accelerator pedal assembly, and remove the accelerator pedal assembly.

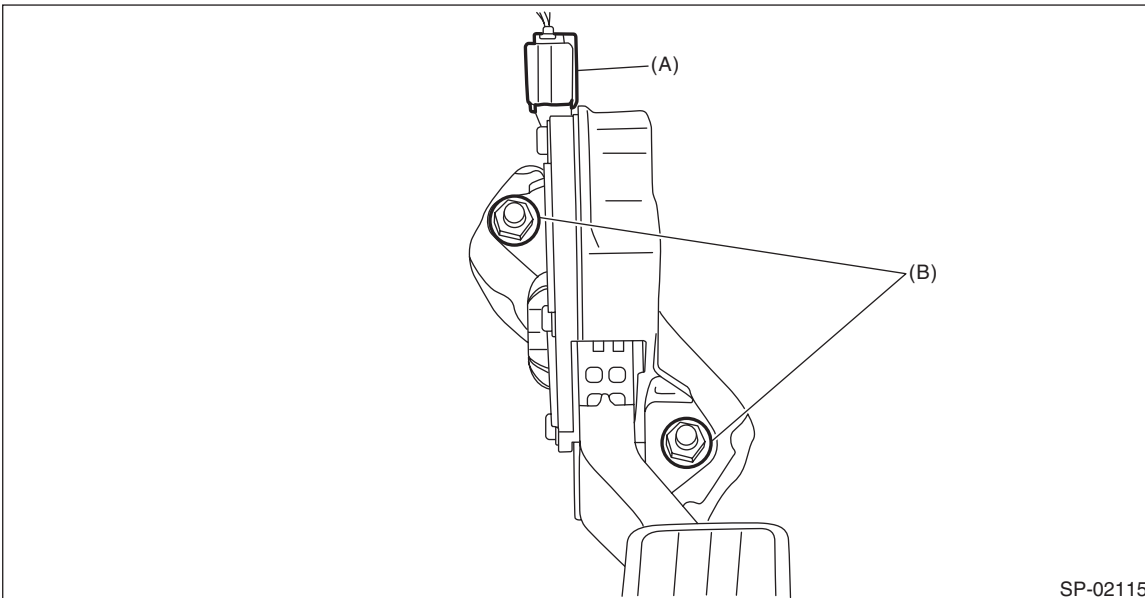

B: INSTALLATION

Install in the reverse order of removal.

Tightening torque:

18 N·m (1.8 kgf·m, 13.3 ft·lb)

C: DISASSEMBLY

NOTE:

The accelerator pedal cannot be disassembled.

D: INSPECTION

1. CHECK ACCELERATOR PEDAL SENSOR AREA (METHOD WITH CIRCUIT TESTER)

- 1) Remove the glove box. <Ref. to EI-65, REMOVAL, Glove Box.>
- 2) Turn the ignition switch to ON. (engine OFF)
- 3) Measure the voltage between ECM connector terminals.

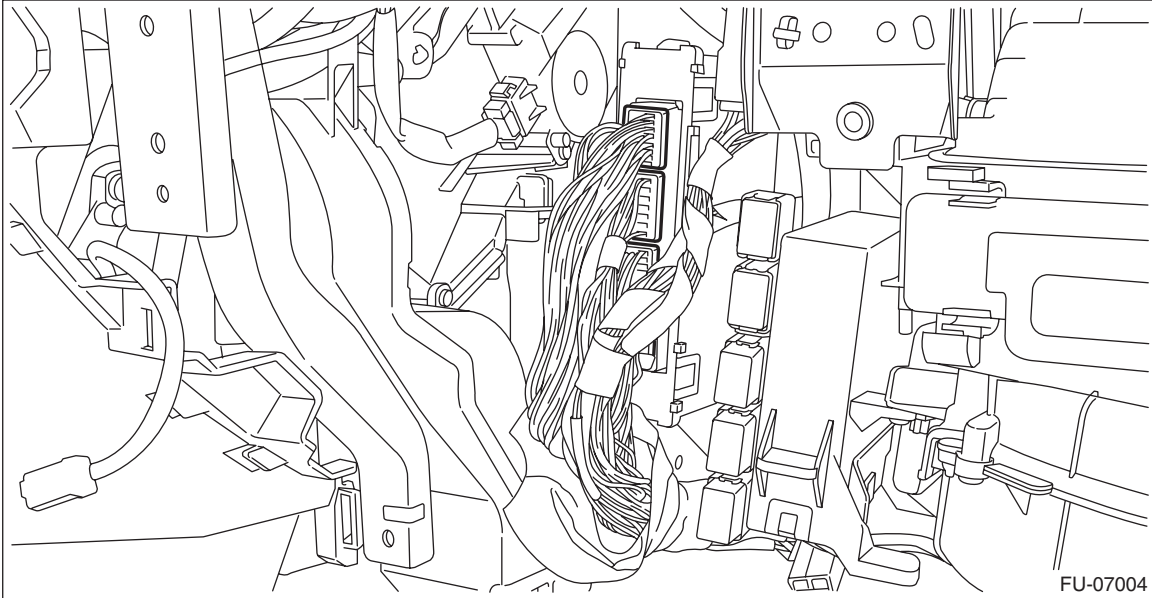

Main sensor side

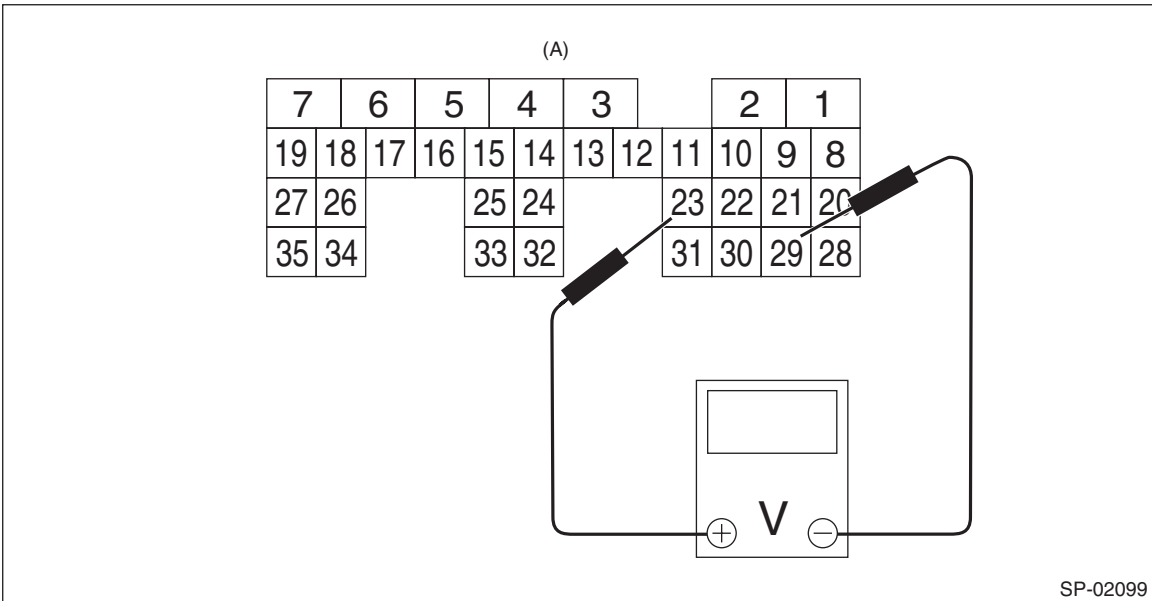

SP-02099

Accelerator Pedal

SPEED CONTROL SYSTEMS

Sub sensor side

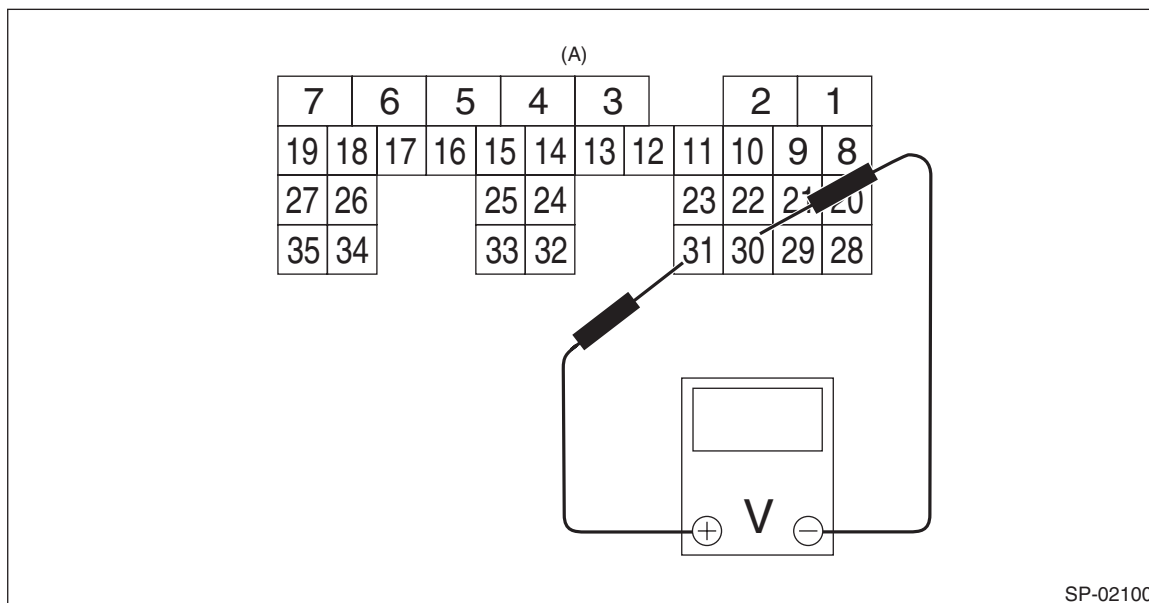

(A) To ECM connector

Accelerator pedal sensor	Accelerator pedal	Terminal No.	Standard
Main	Not depressed (full closed)	23 (+) and 29 (-)	0.4 — 1.0 V
	Depressed (full opened)		2.4 — 3.7 V
Sub	Not depressed (full closed)	31 (+) and 30 (-)	0.3 — 1.1 V
	Depressed (full opened)		2.3 — 3.8 V

4) After inspection, install the related parts in the reverse order of removal.

Tightening torque:

7.5 N·m (0.8 kgf·m, 5.5 ft·lb)

2. CHECK ACCELERATOR PEDAL SENSOR AREA (METHOD WITH SUBARU SELECT MONITOR)

- 1) Turn the ignition switch to ON. (engine OFF)
- 2) Read the accelerator pedal opening angle signal and voltage of accelerator pedal sensor using Subaru Select Monitor. <Ref. to EN(H4DO)(diag)-38, DISPLAY CURRENT ENGINE DATA, OPERATION, Subaru Select Monitor.>

Accelerator pedal sensor	Accelerator pedal opening angle signal	Standard
Main	0.0%	0.4 — 1.0 V
	100.0%	2.4 — 3.7 V
Sub	0.0%	0.3 — 1.1 V
	100.0%	2.3 — 3.8 V

3. OTHER INSPECTIONS

- 1) Check that the accelerator pedal does not have deformation, cracks or damage.
- 2) Check for smooth operation when the accelerator pedal is depressed.
- 3) Check if the accelerator pedal returns to its original position smoothly when the pedal is released.

IGNITION

IG(H4DO)

	Page
1. General Description	2
2. Spark Plug	4
3. Ignition Coil	9