

2. Starter

A: REMOVAL

- 1) Disconnect the ground cable from battery.

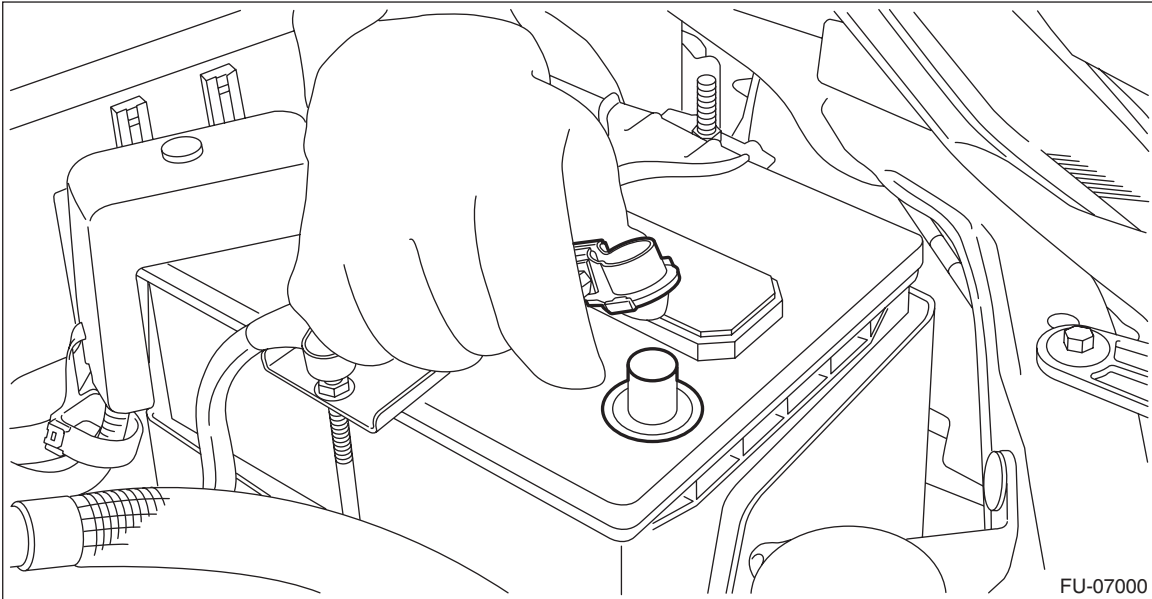

- 2) Remove the clip (A) from the air intake boot.
- 3) Loosen the clamp (B) connecting the air intake boot and air cleaner case (rear).
- 4) Loosen the clamp (C) which connects the air intake boot and throttle body.

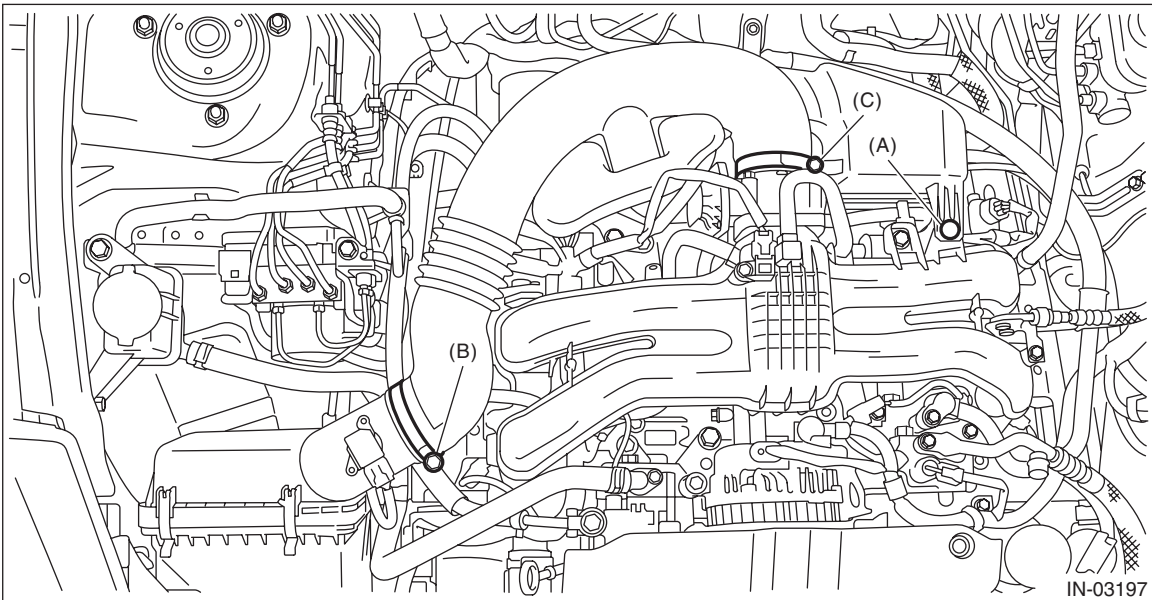

Starter

STARTING/CHARGING SYSTEMS

- 5) Remove the air intake boot from the throttle body, and move the air intake boot to the left side wheel apron.

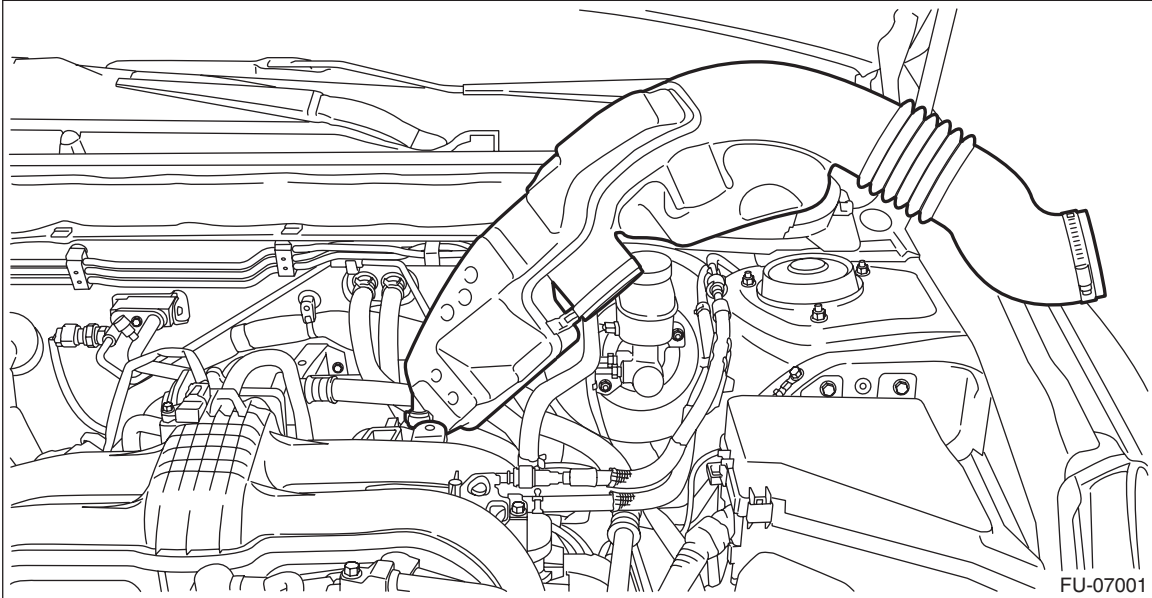

- 6) Disconnect the connector (B) and terminal (A) from starter.

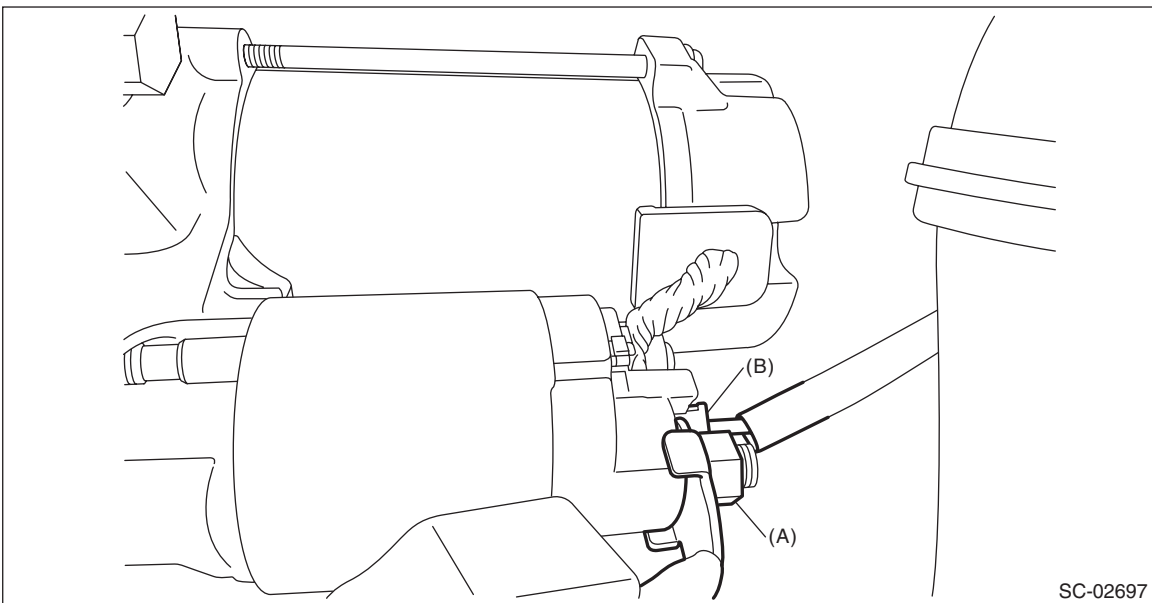

- 7) Lift up the vehicle.

8) Remove the lower nut (A) from the starter.

NOTE:

For the MT model, a bolt is used to the location (A).

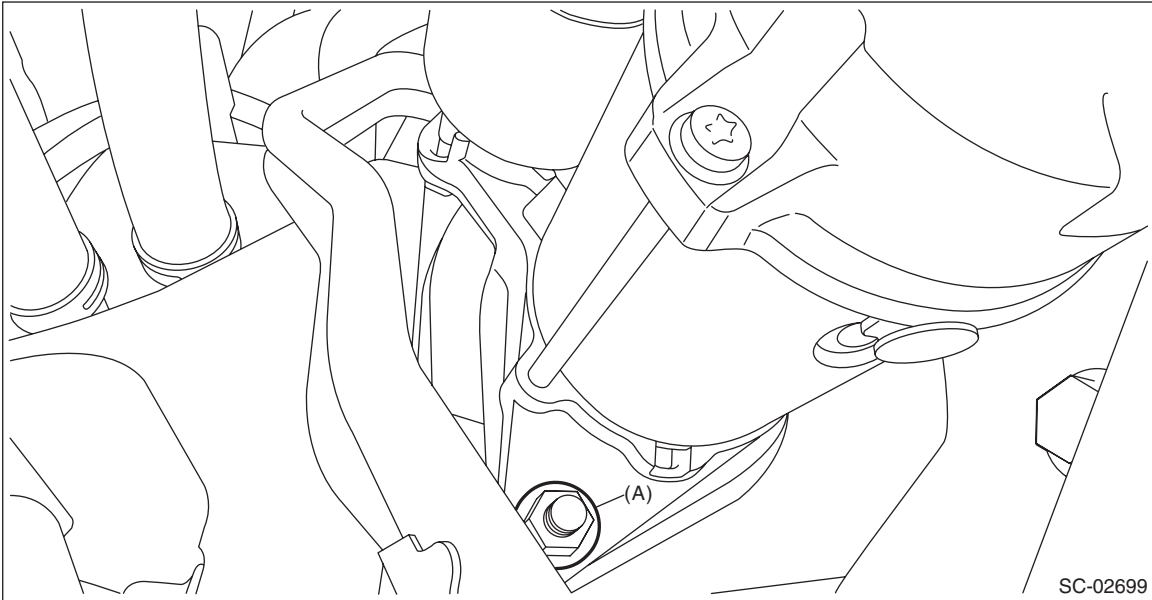

9) Lower the vehicle.

10) Remove the upper bolt from the starter and remove the starter from the transmission.

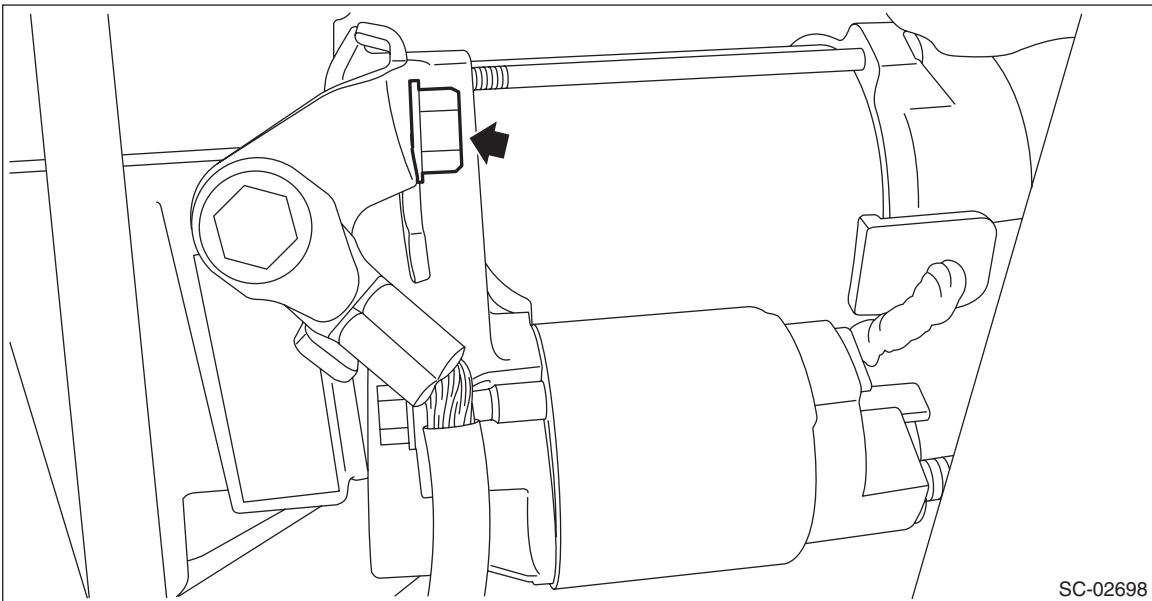

Starter

STARTING/CHARGING SYSTEMS

B: INSTALLATION

Install in the reverse order of removal.

NOTE:

For the MT model, a bolt is used to the location (A).

Tightening torque:

50 N·m (5.1 kgf·m, 36.9 ft·lb)

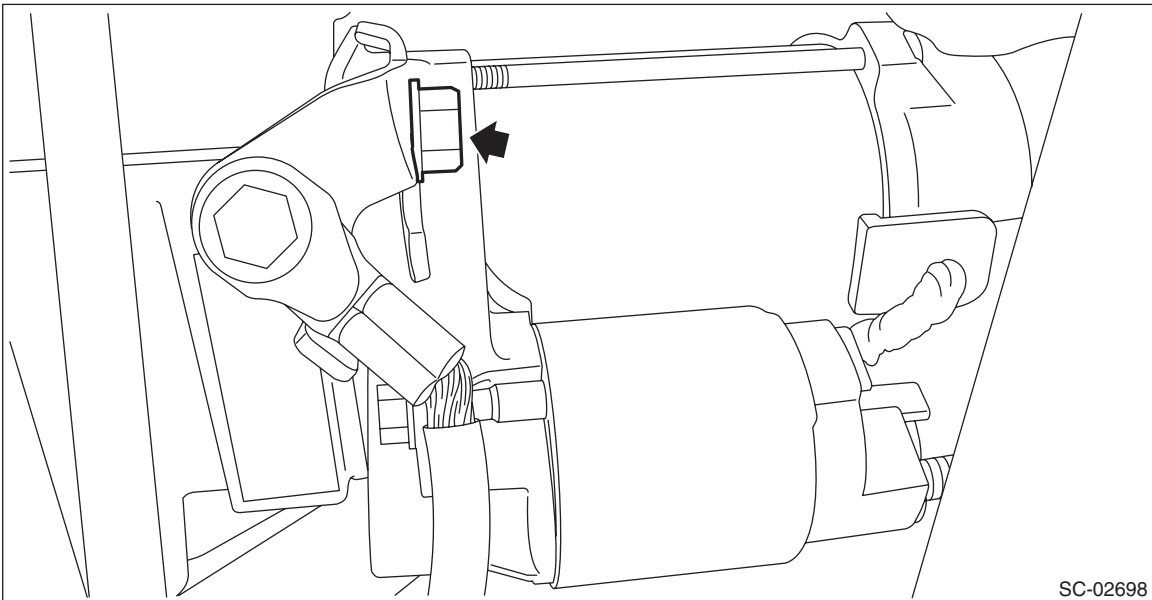
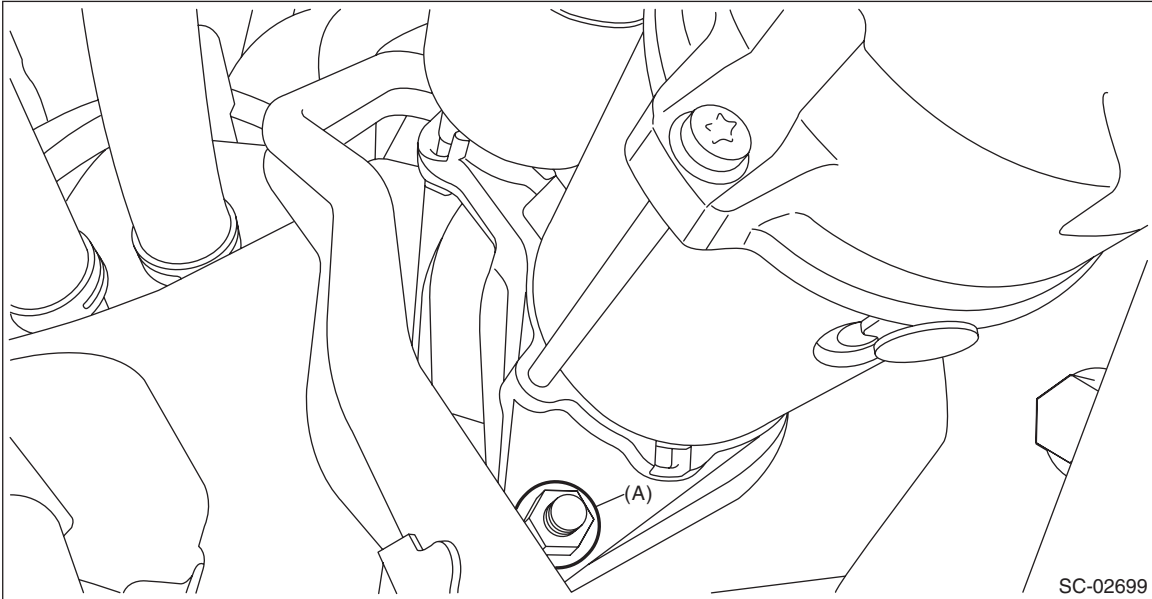

Tightening torque:
10 N·m (1.0 kgf·m, 7.4 ft·lb)

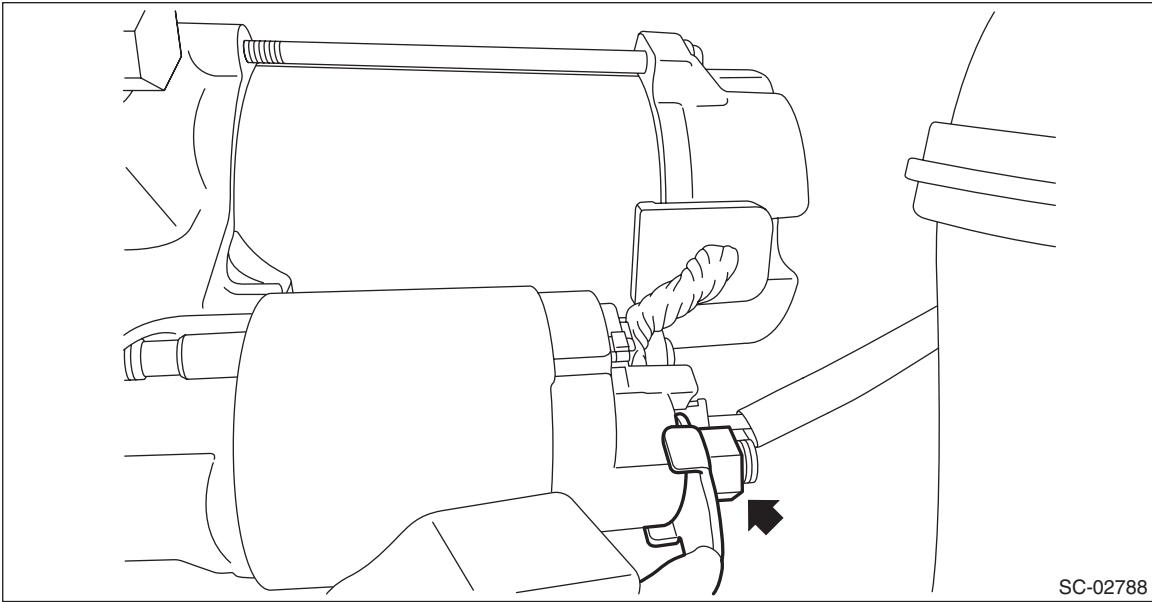

Tightening torque:
3 N·m (0.3 kgf·m, 2.2 ft·lb)

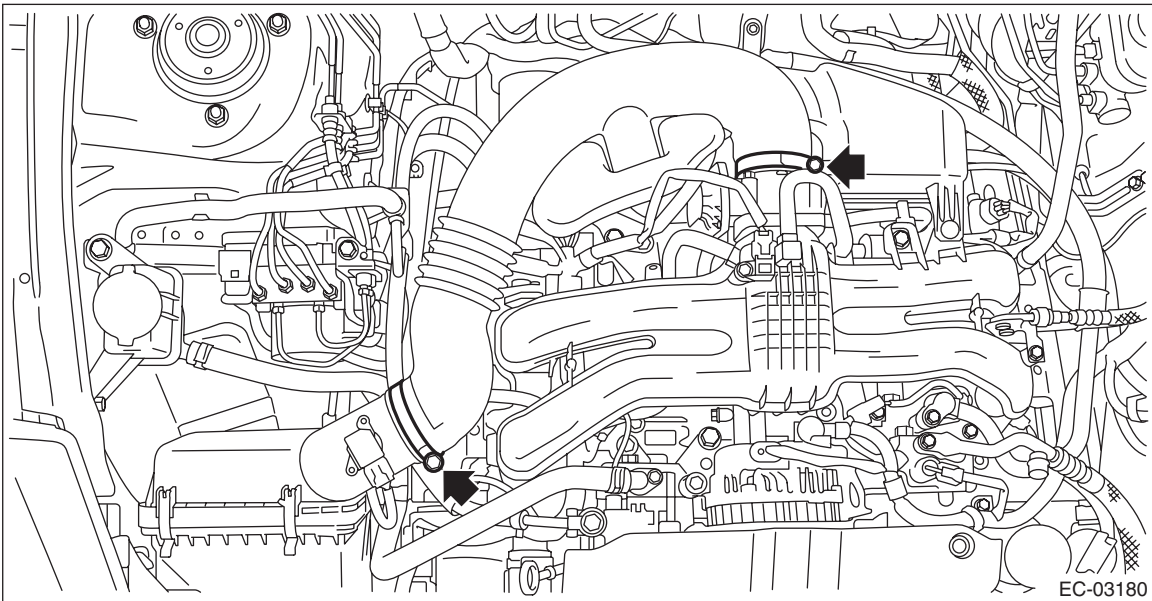

Starter

STARTING/CHARGING SYSTEMS

C: DISASSEMBLY

1) Remove the nut which holds terminal M (A) of the magnet switch assembly, then disconnect the harness from the terminal.

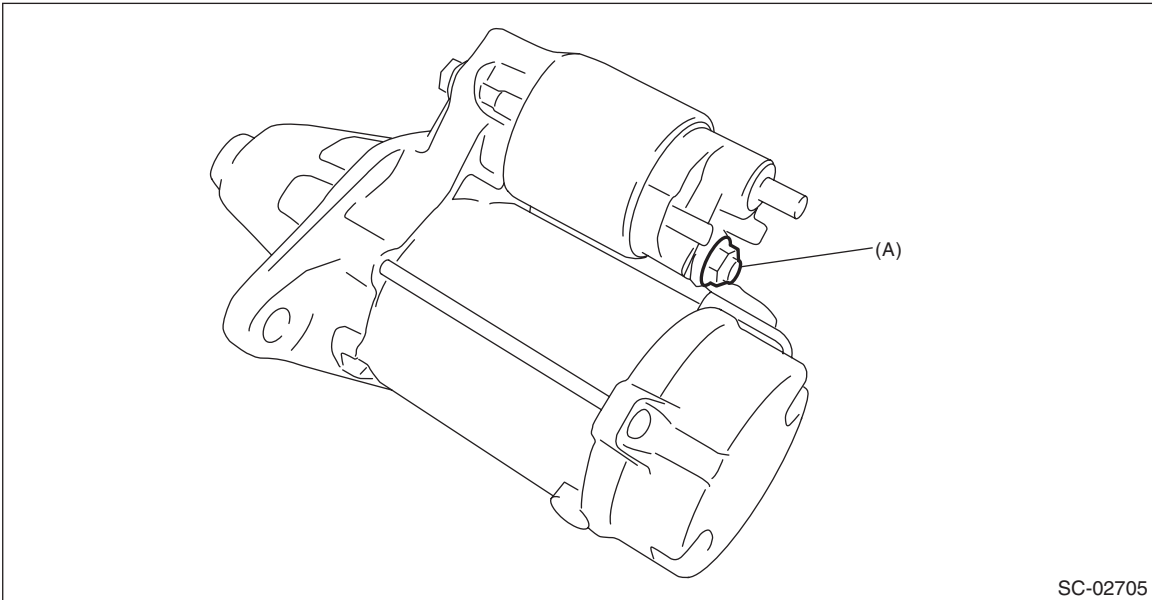

2) Remove the nuts fastening the magnet switch assembly to the starter housing, then remove the magnet switch assembly.

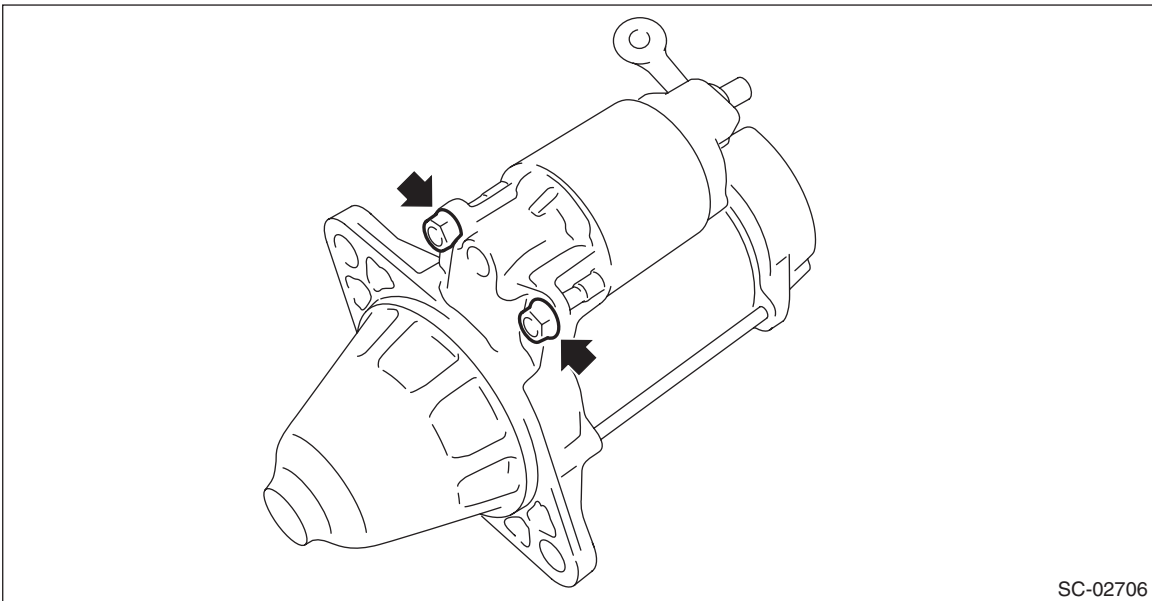

3) Remove the starter seal.



SC-02707

Starter

STARTING/CHARGING SYSTEMS

- 4) Remove the through bolts on both sides, and remove the starter housing.

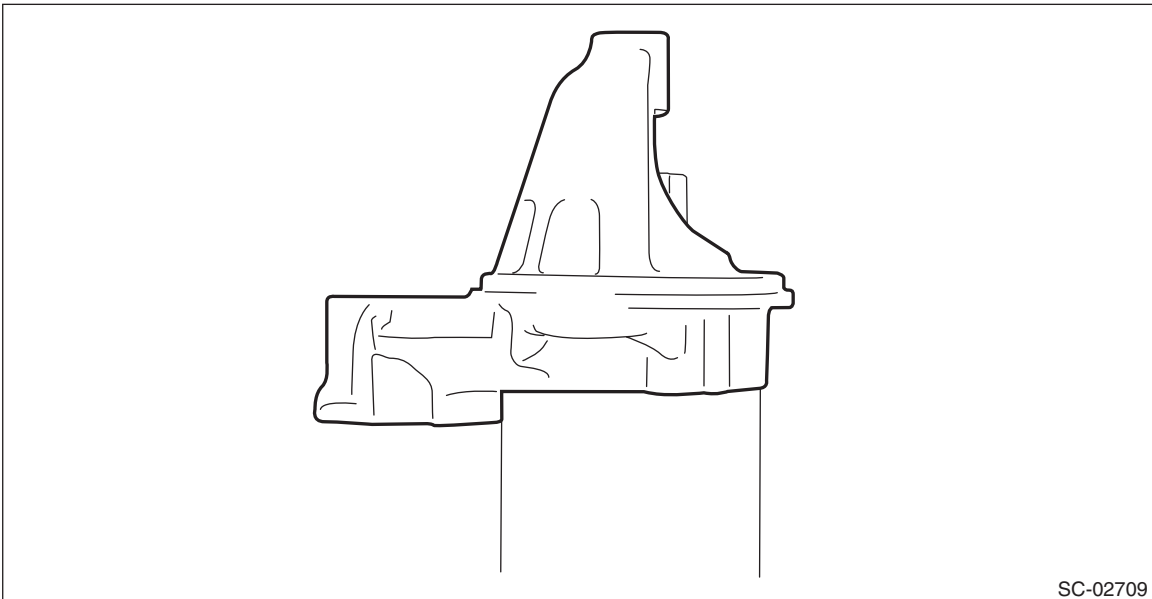
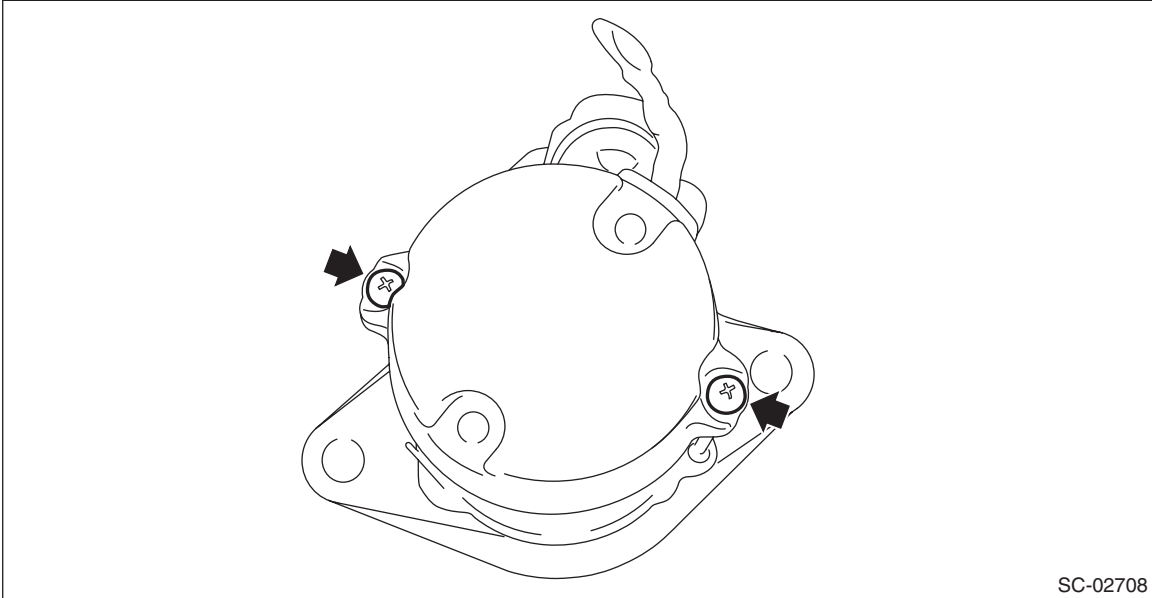

5) Remove the shift lever.

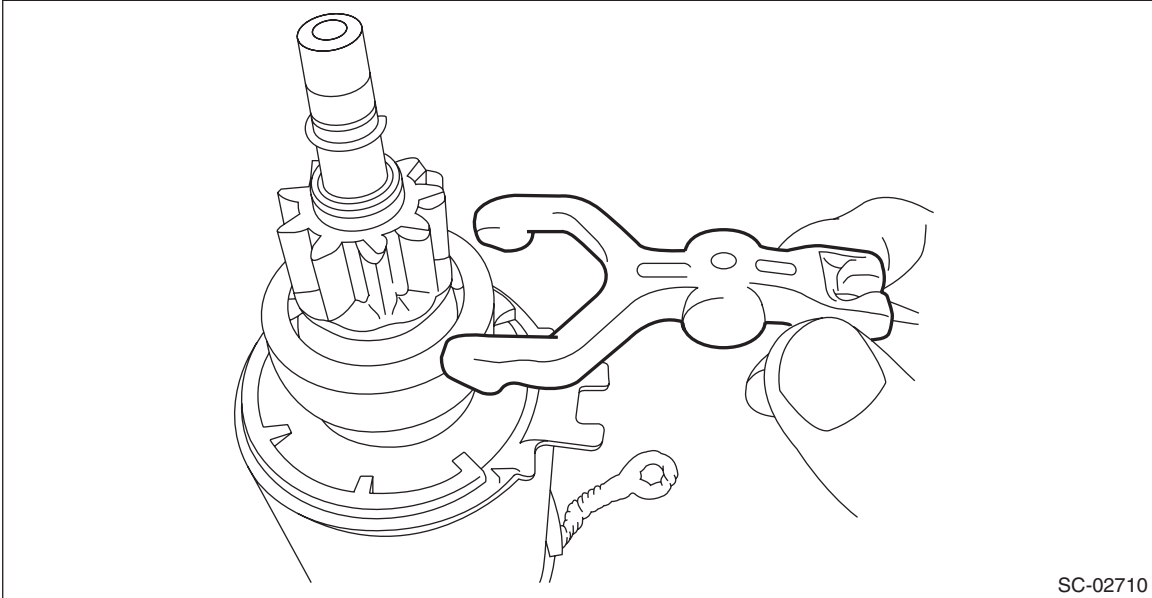

6) Remove the overrunning clutch assembly from the yoke.

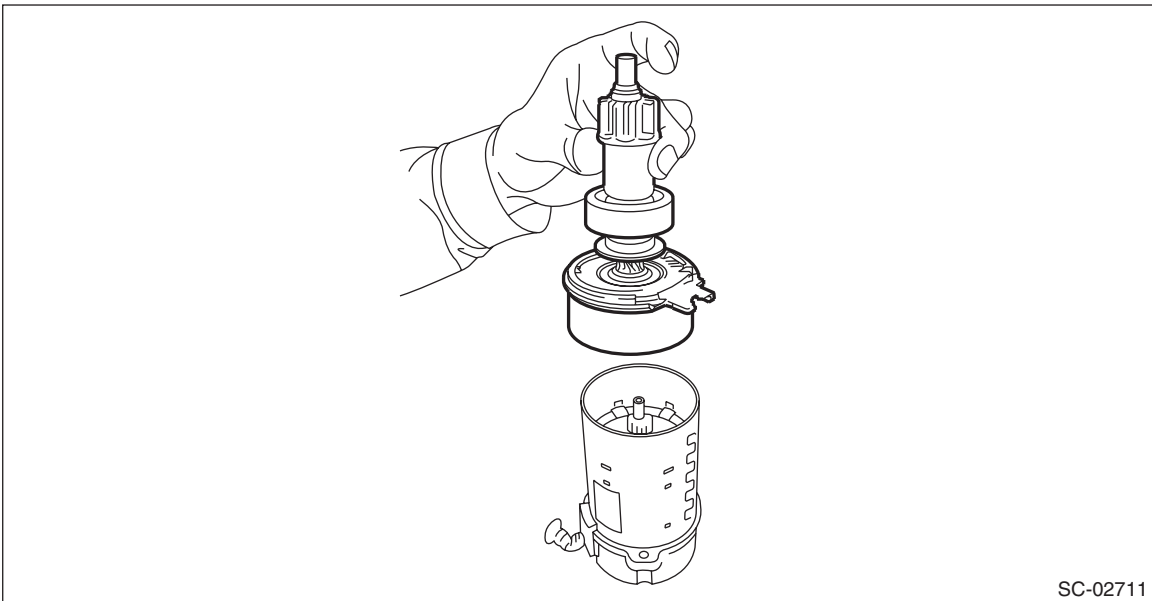

Starter

STARTING/CHARGING SYSTEMS

7) Remove the starter plate.

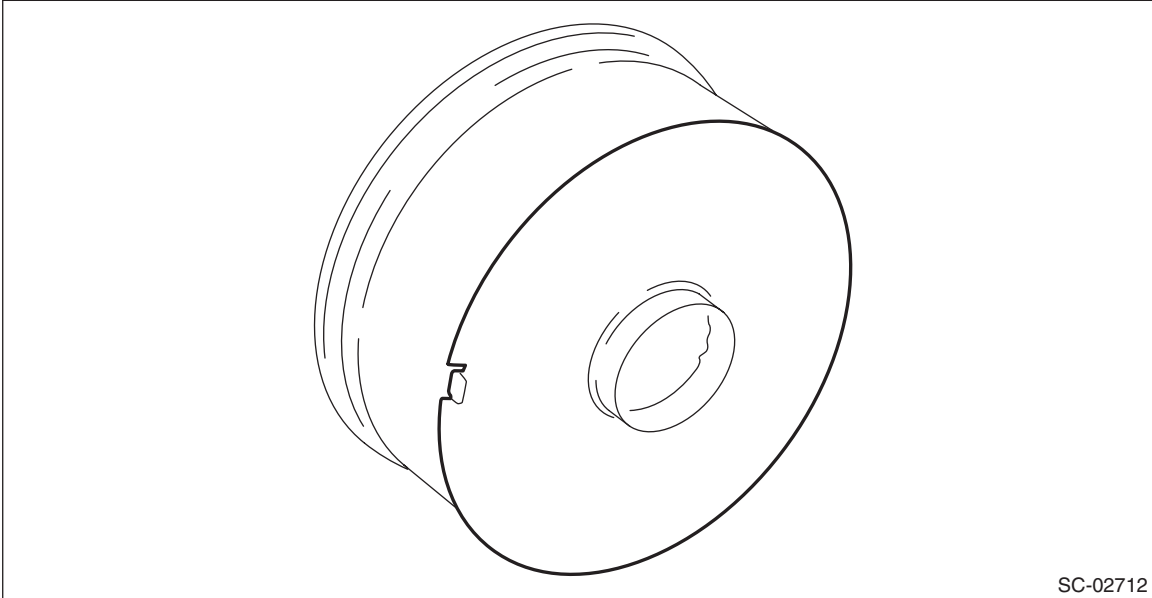

SC-02712

8) Remove the planetary gear (A) and washer (B) from internal gear.

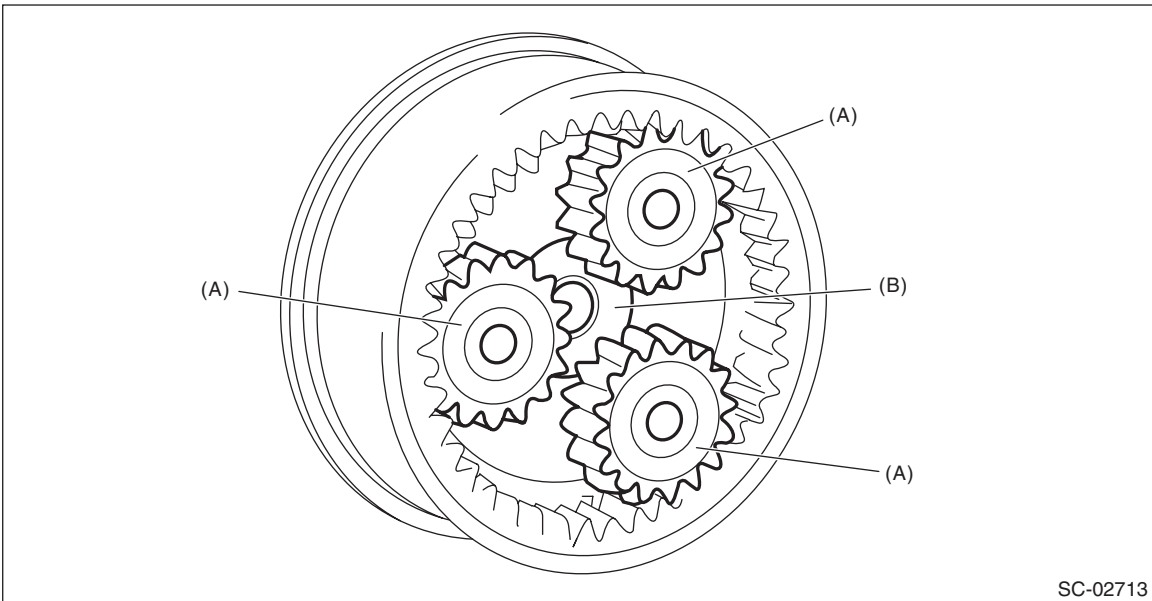

SC-02713

9) Remove the screws, and remove the starter cover from the brush holder assembly.

NOTE:

Separate the starter cover by pressing the brush holder assembly using the screws so that the assembly stays onto the armature side.

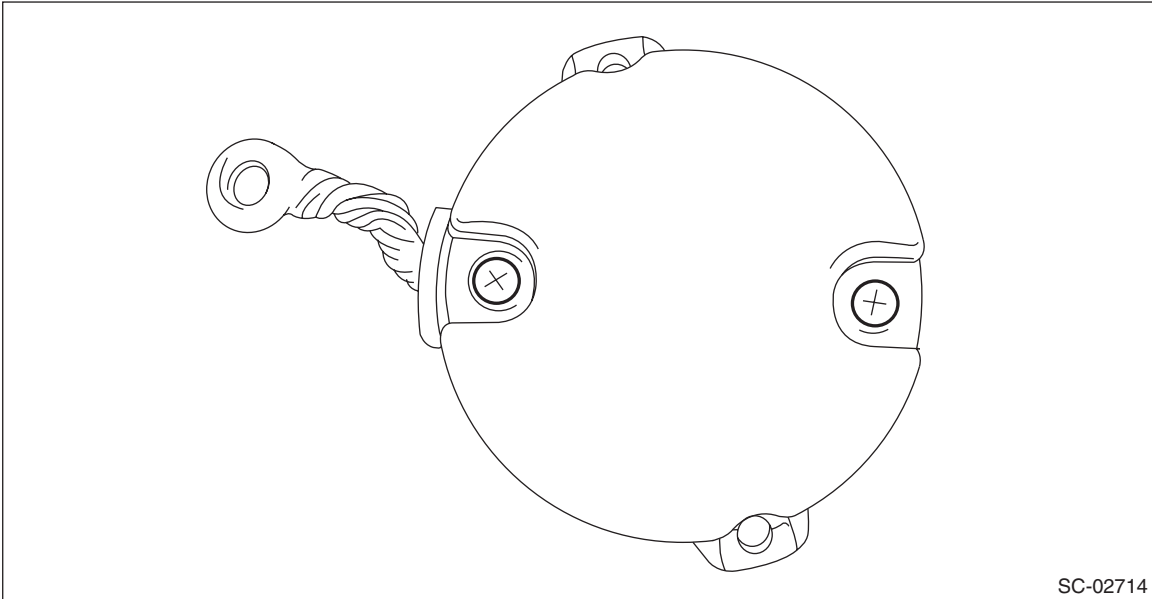

SC-02714

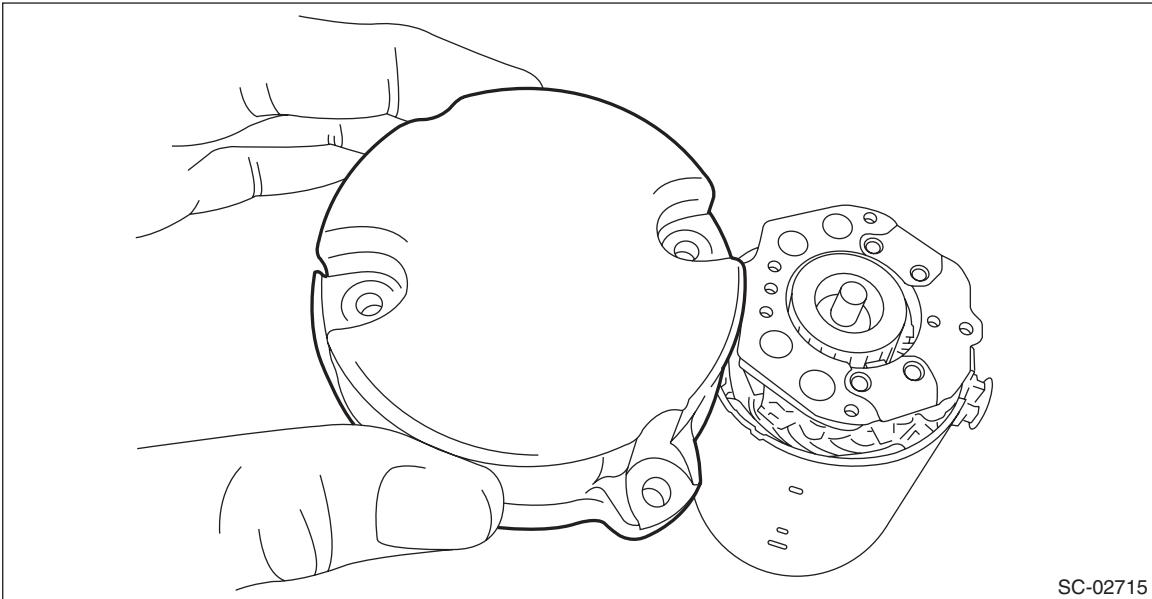

SC-02715

Starter

STARTING/CHARGING SYSTEMS

10) Remove the brush holder assembly from the armature.

NOTE:

Spread the brush with your fingers, being careful not to damage the brush.

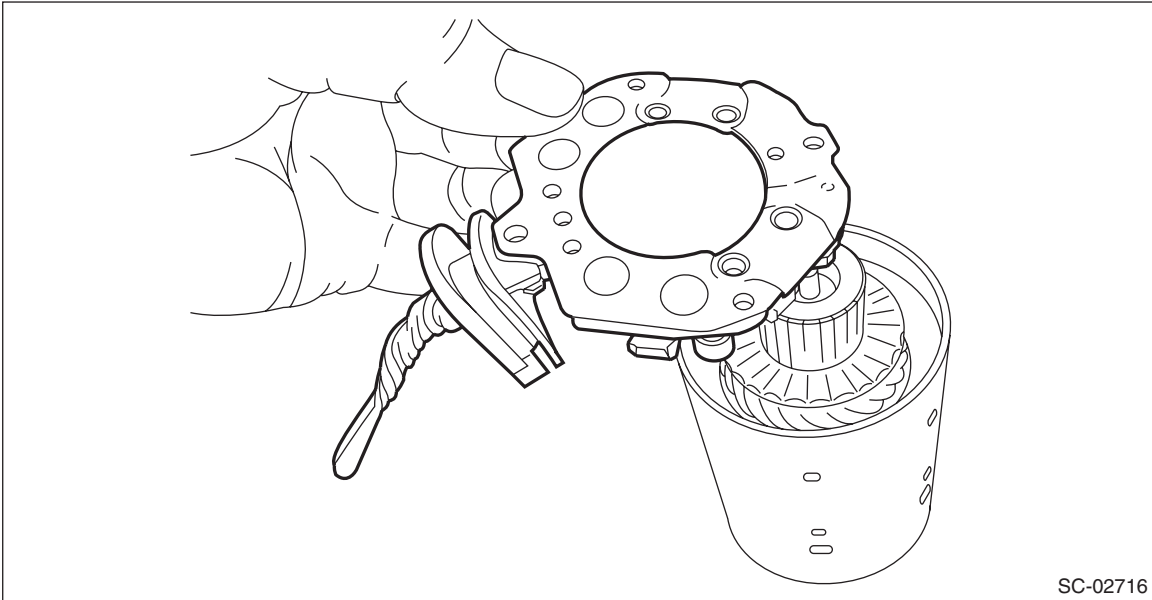

11) Remove the armature from the yoke.

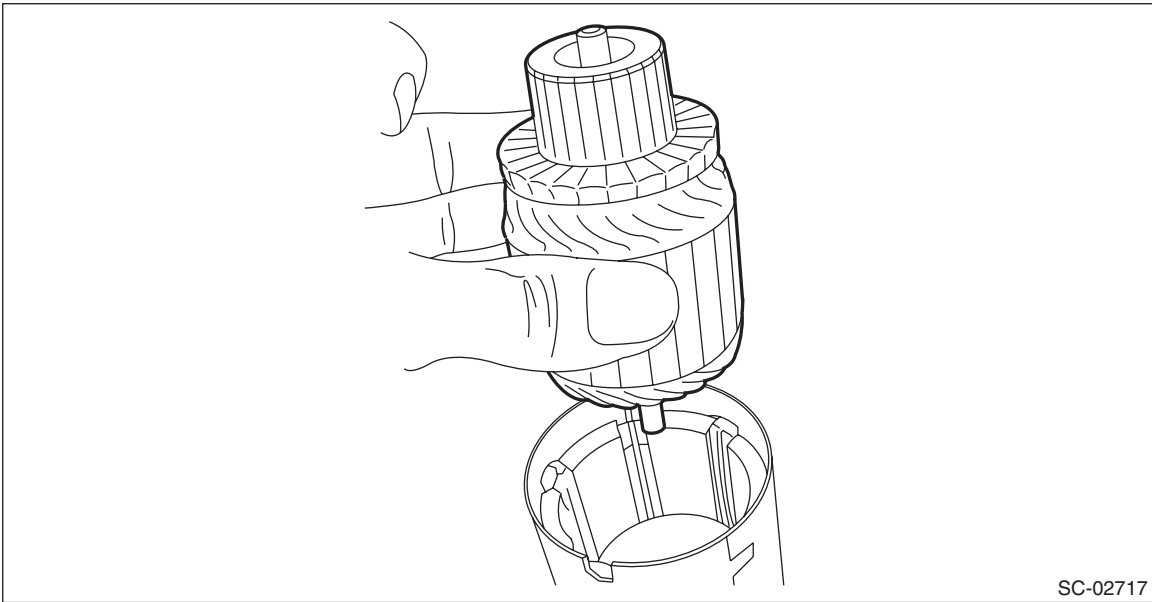

D: ASSEMBLY

- 1) Install the armature to the yoke.

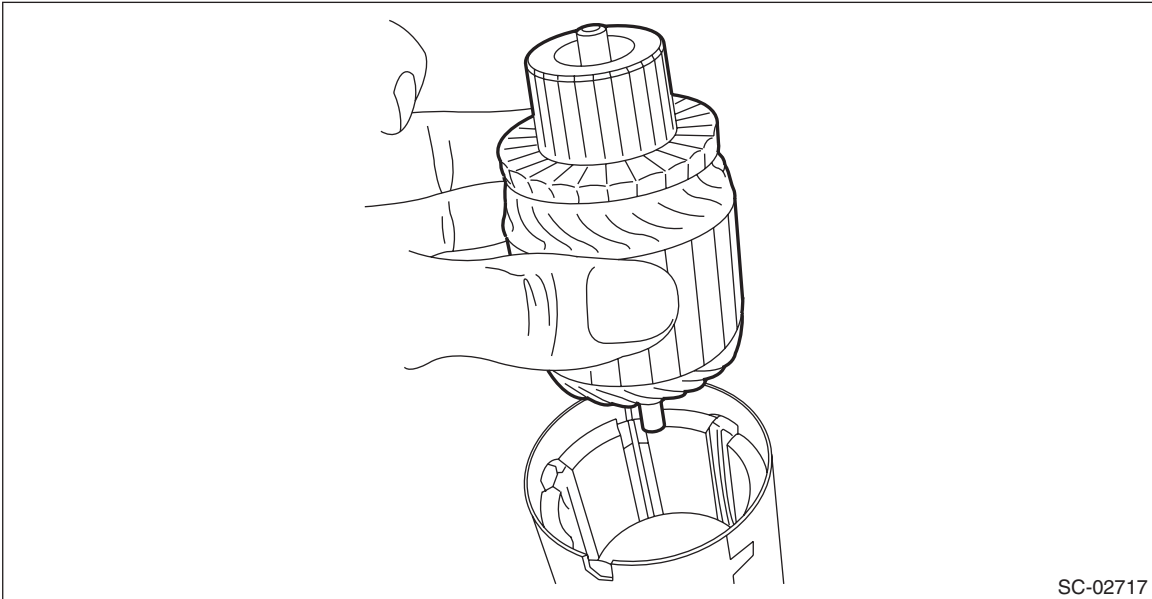

SC-02717

- 2) Install the brush holder assembly to the armature.

NOTE:

Spread the brush with your fingers, being careful not to damage the brush.

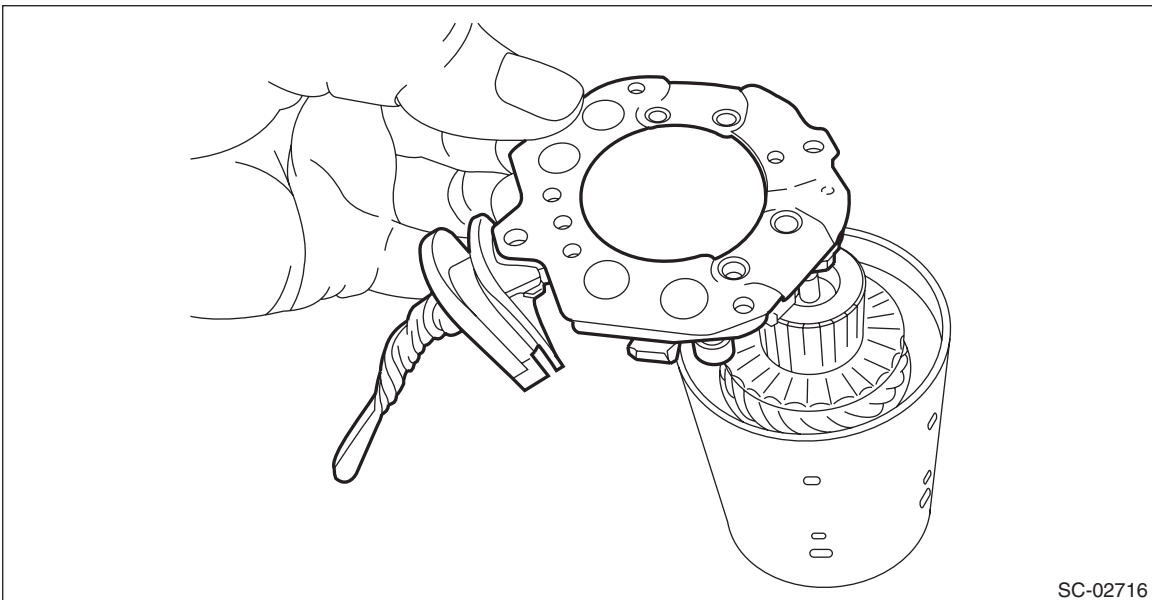

SC-02716

Starter

STARTING/CHARGING SYSTEMS

3) Install the starter cover, and secure it to the brush holder assembly with the screws.

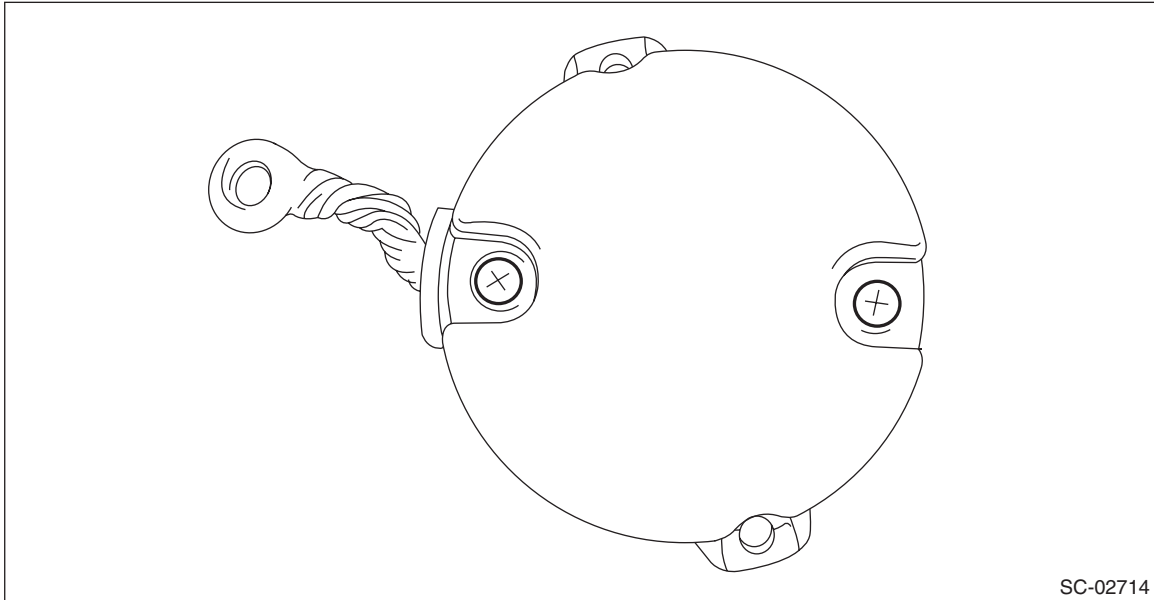

4) Assemble the planetary gear (A) and washer (B) to the internal gear.

(1) Apply grease to the planetary gear installation position.

Grease:

DENSO HL50

(2) Install the planetary gear to the pin.

(3) Apply grease to the planetary gear, internal gear, washer, and upper part of the pin.

NOTE:

- Apply grease so that it contacts each gear.
- Be careful not to allow dirt to get in.

Grease:

DENSO HL50

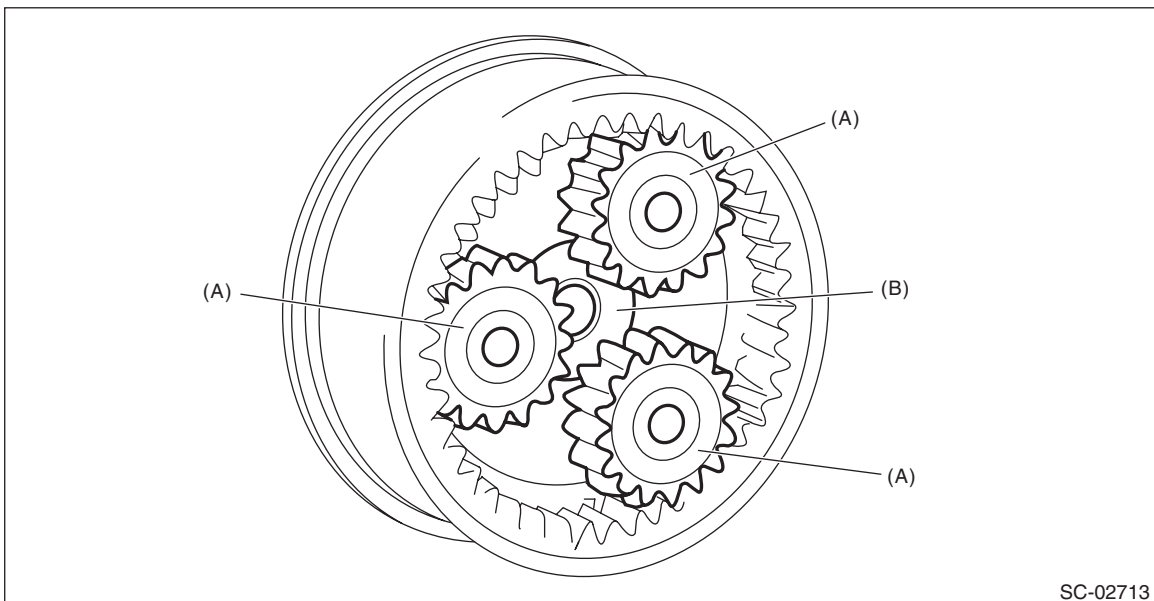

(4) Install the starter plate.

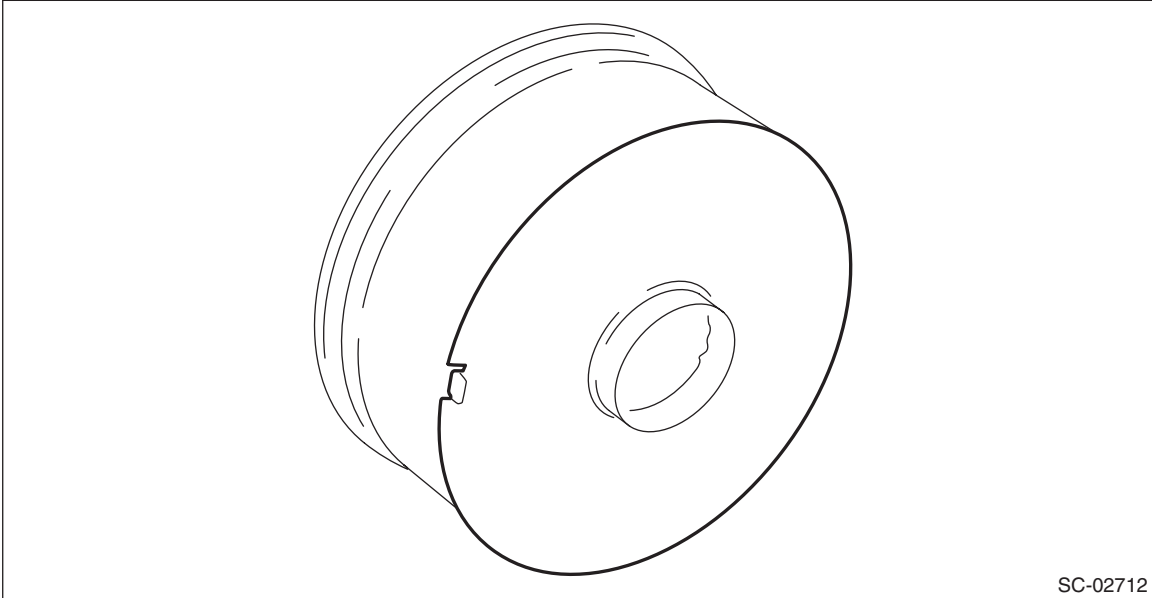

SC-02712

5) Assemble the overrunning clutch assembly to the yoke.

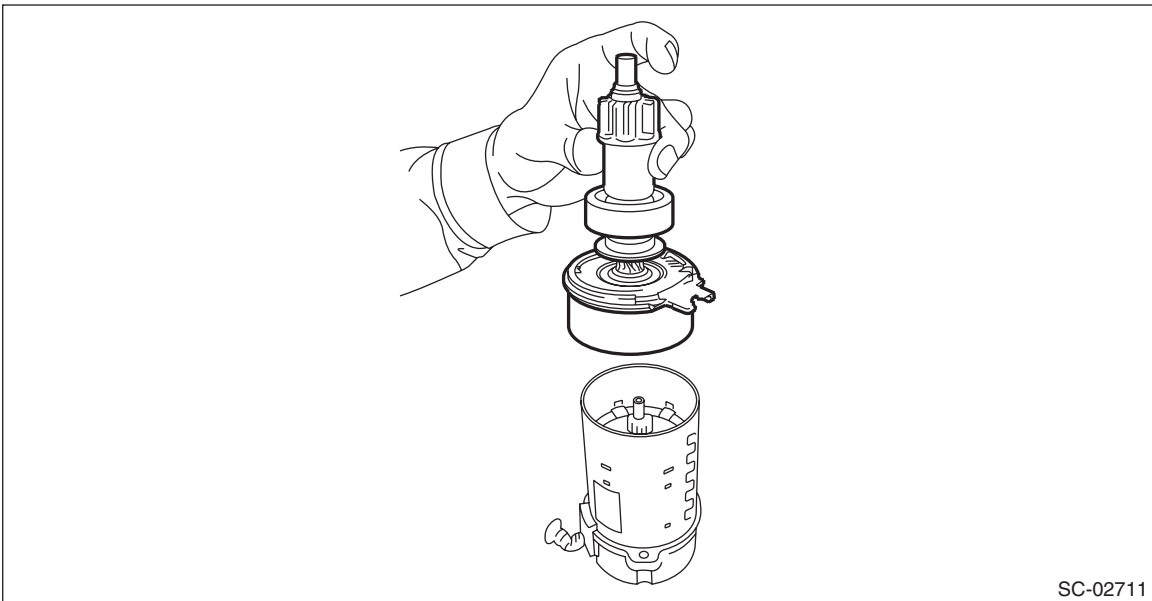

SC-02711

Starter

STARTING/CHARGING SYSTEMS

6) Install the shift lever.

NOTE:

Apply grease to the contact portion of the shift lever.

Grease:

DENSO HL50

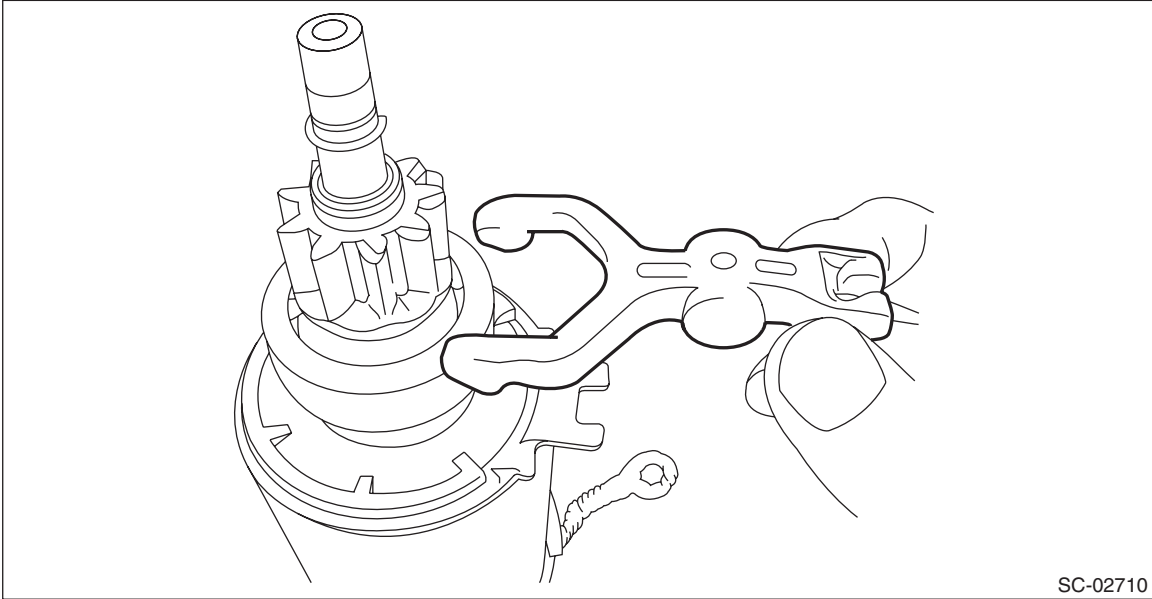

7) Install the starter housing, and tighten through bolts on both sides.

Tightening torque:

6 N·m (0.6 kgf·m, 4.4 ft·lb)

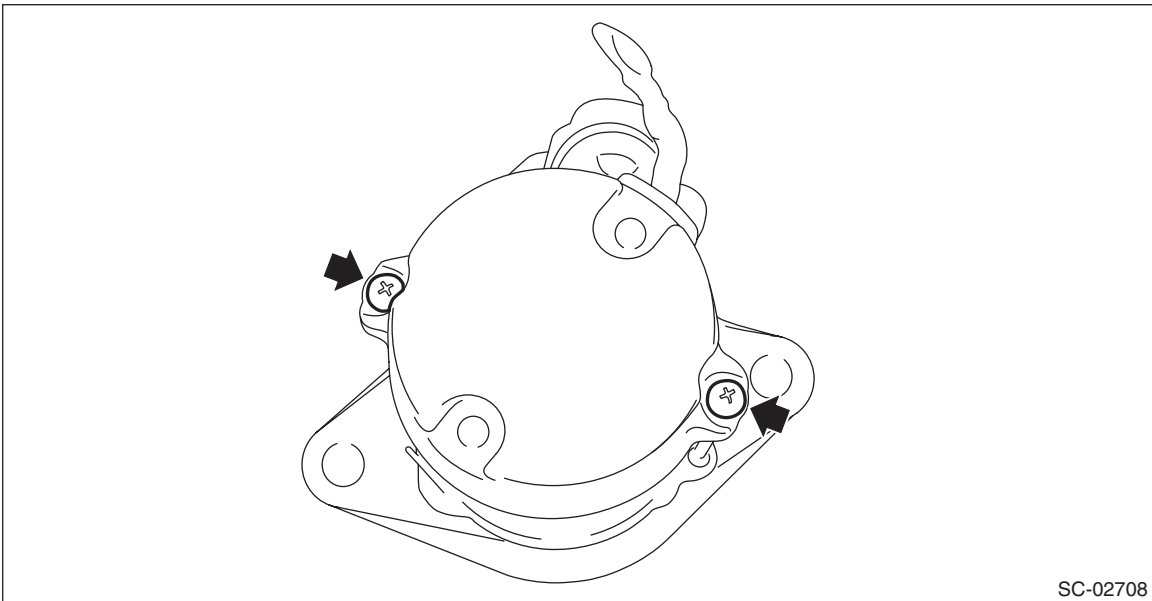
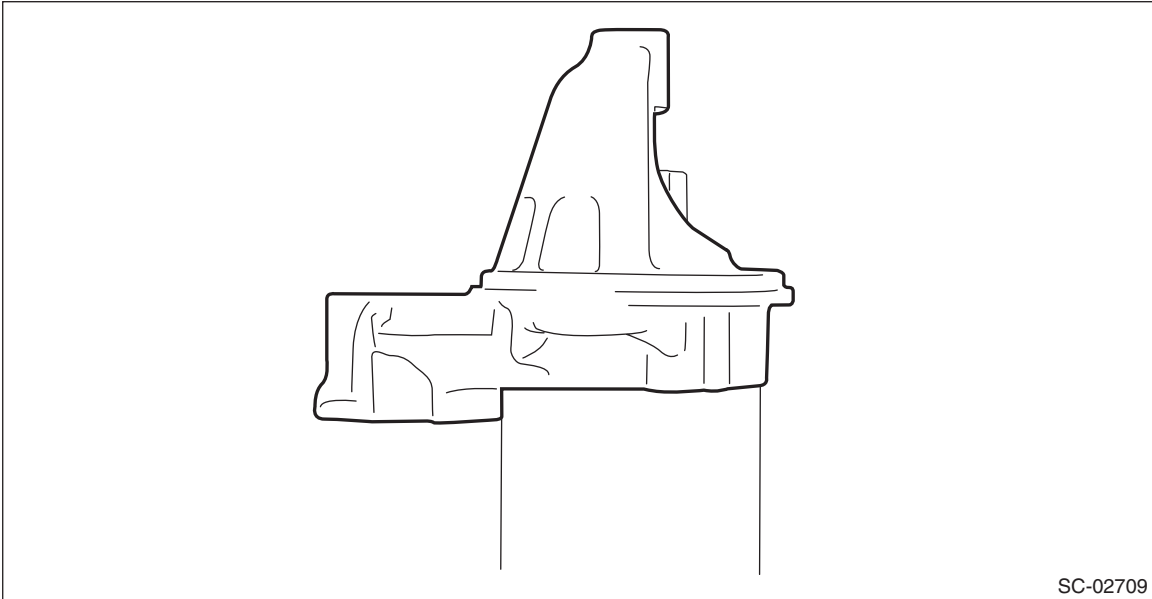

Starter

STARTING/CHARGING SYSTEMS

8) Install the starter seal.



SC-02707

9) Install the magnet switch assembly to the starter housing, and tighten the nuts.

NOTE:

Apply grease to the shift lever installation position.

Grease:

DENSO HL50

Tightening torque:

7.5 N·m (0.8 kgf-m, 5.5 ft-lb)

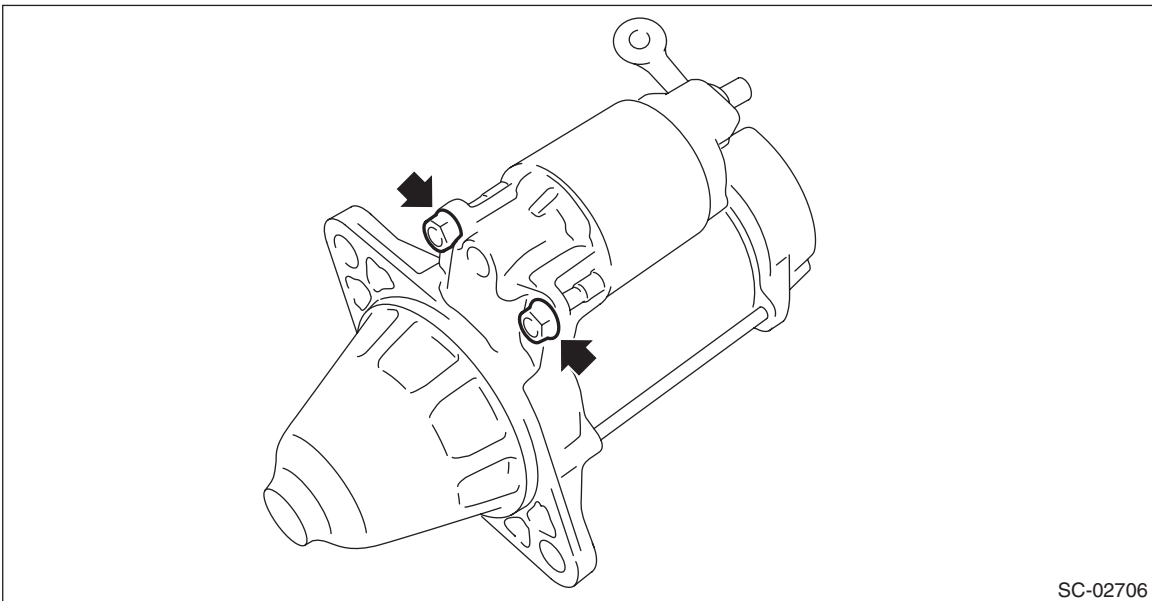

SC-02706

10) Install the harness to the terminal M (A) of the magnet switch assembly, and tighten the nut.

Tightening torque:

10 N·m (1.0 kgf·m, 7.4 ft·lb)

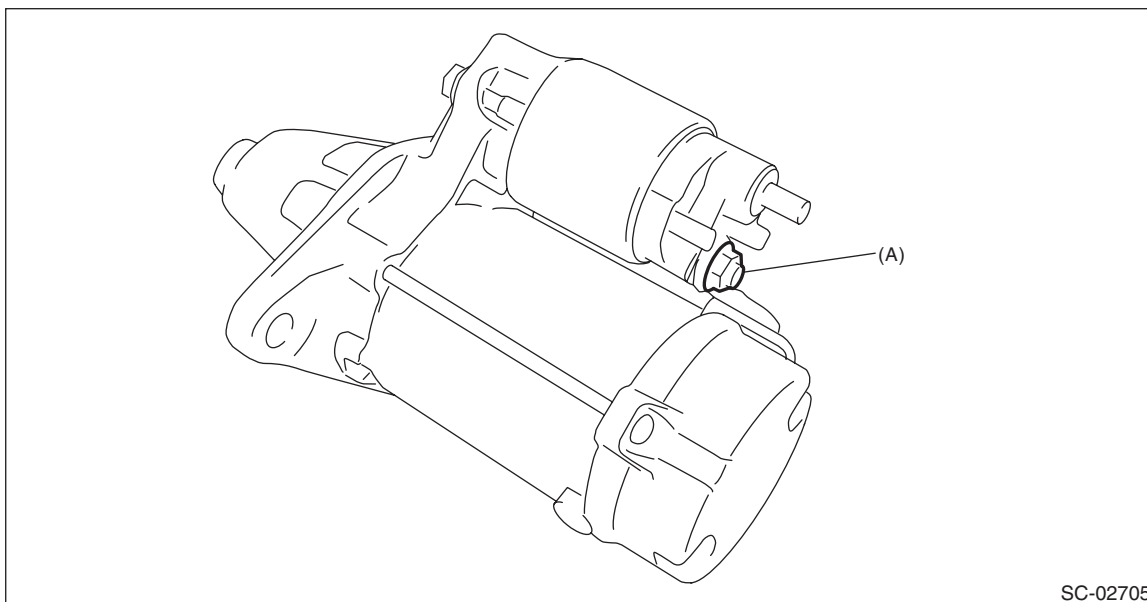

SC-02705

E: INSPECTION

1. SWITCH ASSEMBLY

Using a circuit tester (set to “ohm”), check that there is continuity between terminals S and M, and between terminal S and ground.

Also check to be sure there is no continuity between terminal M and B.

Terminal/Resistance:

S — M/1 Ω or less

S — Ground/1 Ω or less

M — B/1 M Ω or more

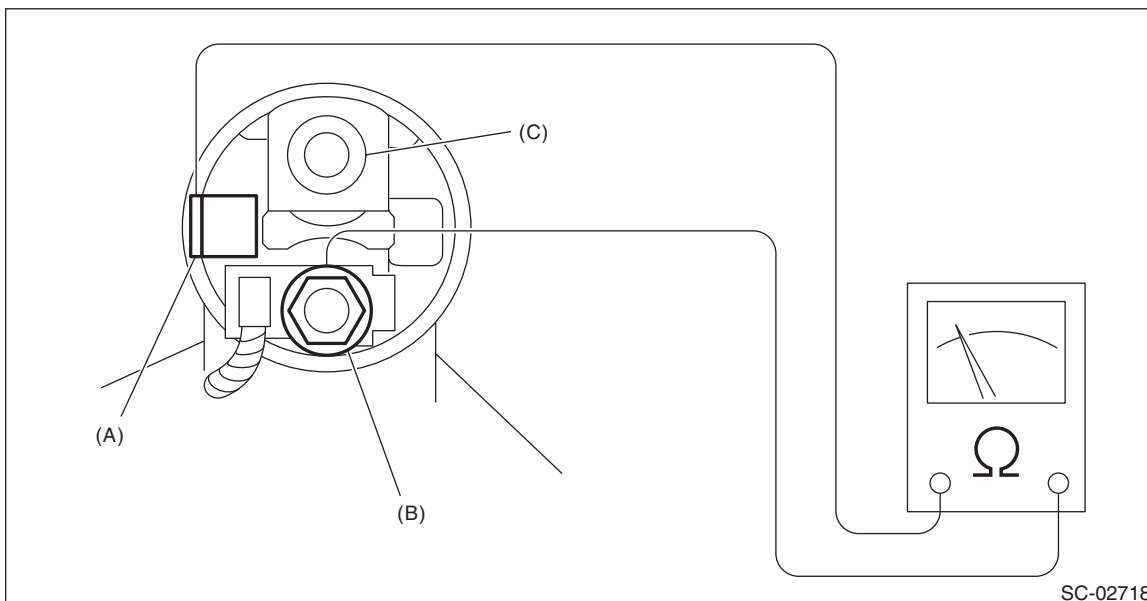

SC-02718

(A) Terminal S

(B) Terminal M

(C) Terminal B

Starter

STARTING/CHARGING SYSTEMS

2. SWITCH ASSEMBLY OPERATION

NOTE:

Perform each test in a short period of time (3 — 5 sec).

1) Suction test

Check that the pinion gear comes flying out when the harness is disconnected from terminal M and connected as shown in the figure.

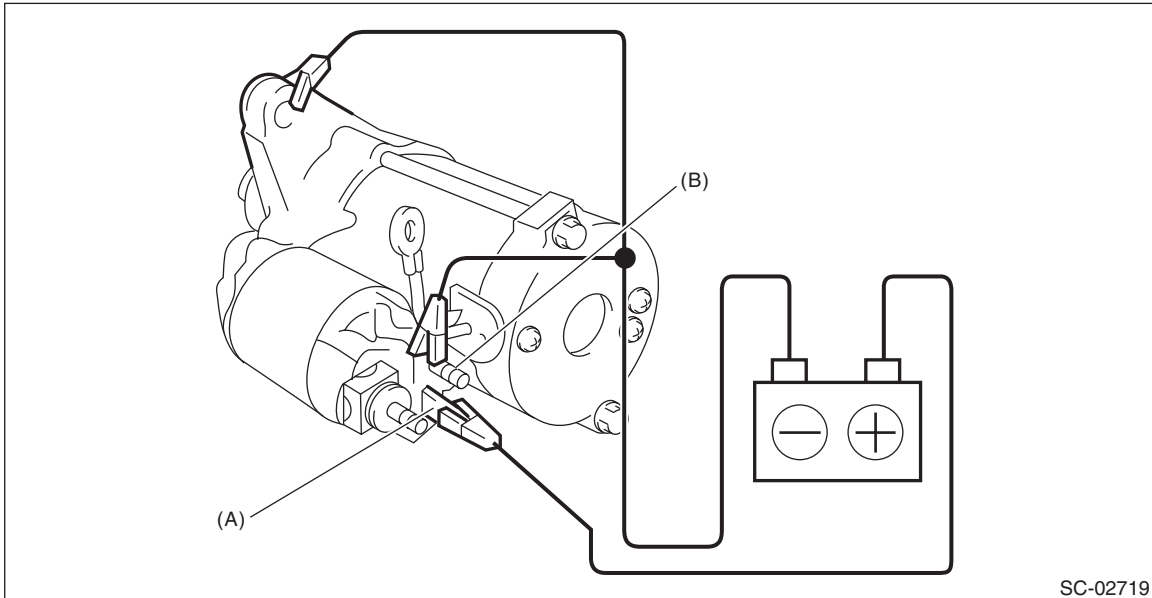

(A) Terminal S

(B) Terminal M

2) Holding test

Check that the pinion gear remains flying out after the cable is disconnected from terminal M.

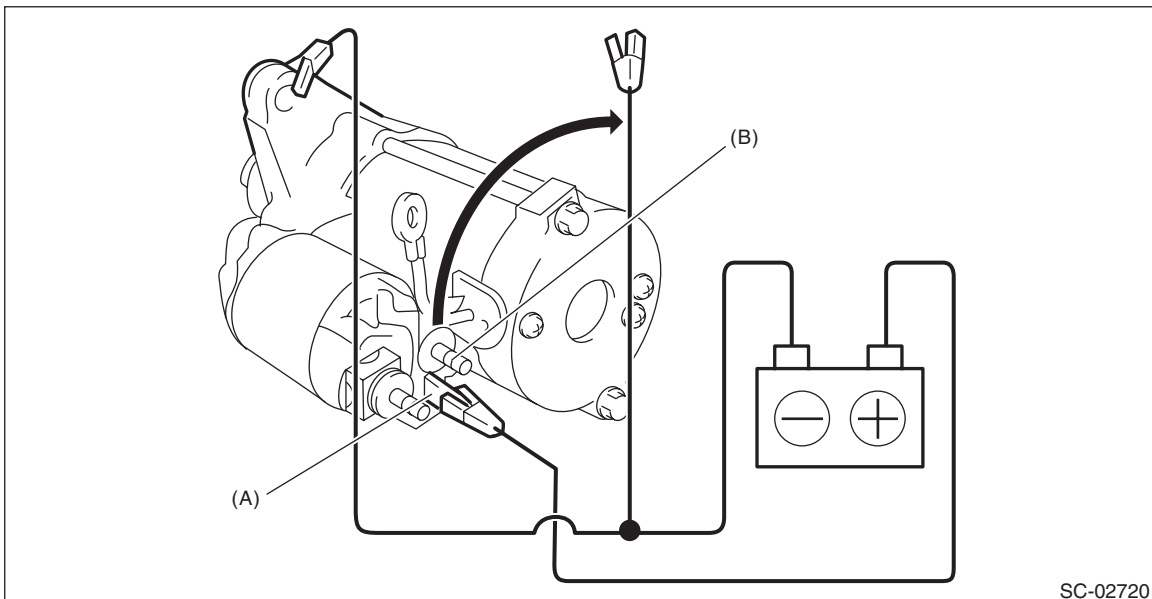

(A) Terminal S

(B) Terminal M

3) Returning test

With terminal S connected to the positive terminal, and terminal M and starter body connected to the battery ground terminal to suction the main contact point, check that the pinion gear returns to its original position when terminal S is disconnected.

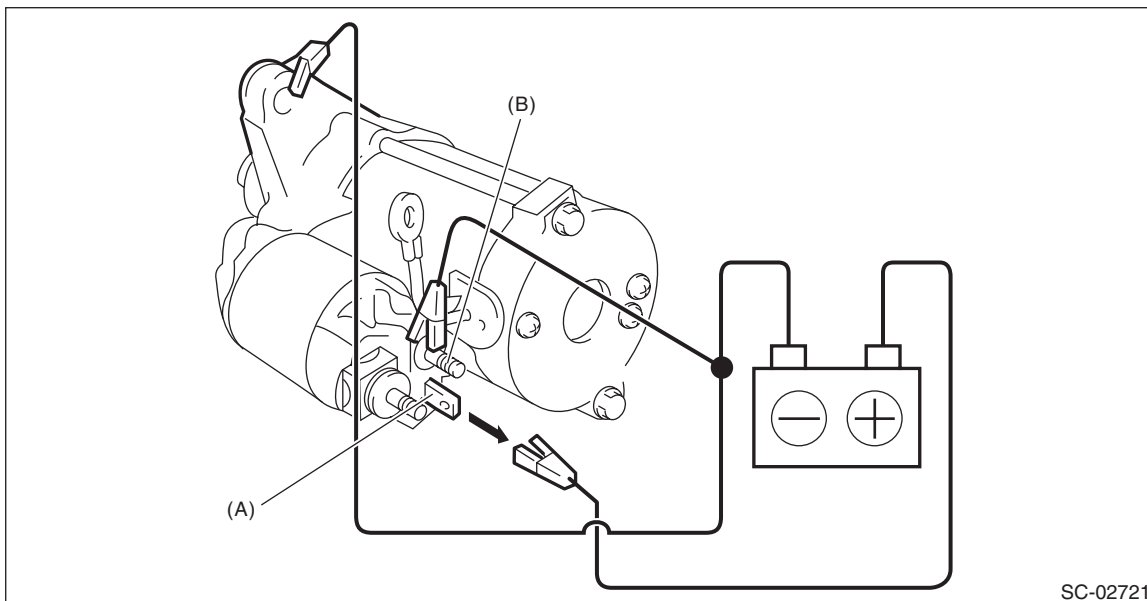

(A) Terminal S

(B) Terminal M

3. PERFORMANCE TEST

The starter should be submitted to performance tests whenever it has been overhauled, to assure its satisfactory performance when installed on the engine.

Three performance tests, no-load test, load test, and lock test, are presented here; however, if the load test and lock test cannot be performed, carry out at least the no-load test.

For these performance tests, use the circuit shown in figure.

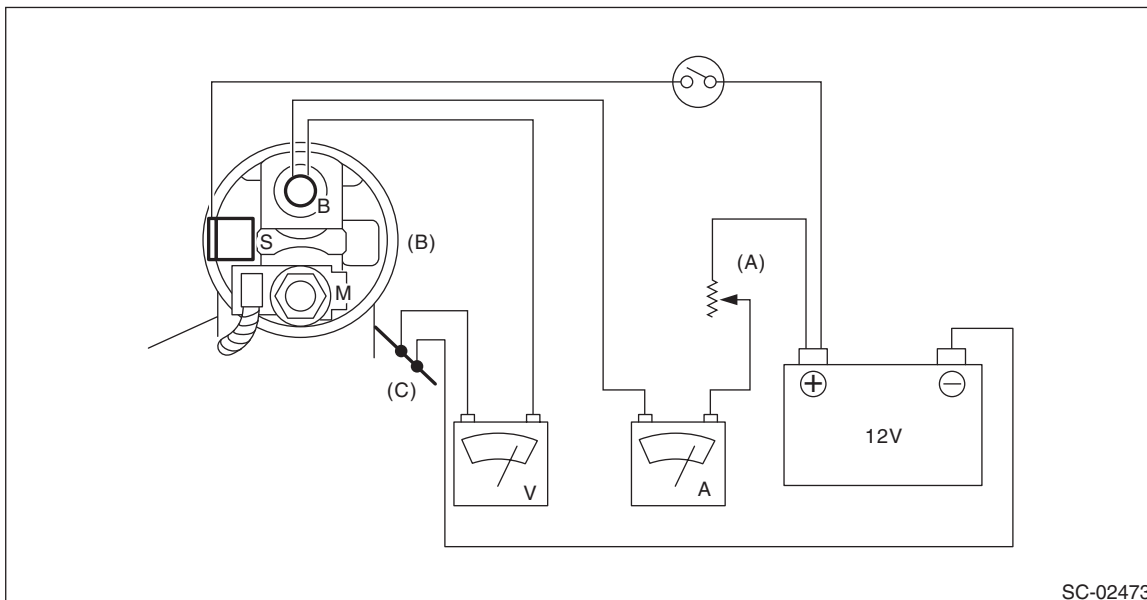

(A) Variable resistance

(B) Magnetic switch

(C) Starter body

Starter

STARTING/CHARGING SYSTEMS

1) No-load test

Adjust the variable resistance with the switch on until the voltage is 11 V, and read the value displayed on the ammeter to measure rotating speed. Compare these values with the standard.

No-load test (standard):

Voltage/Current

Max. 11 V/90 A or less

Rotating speed

1,900 rpm or more

2) Load test

Apply the specified braking torque to starter. The condition is normal if the current draw and rotating speed are within standard.

Load test (standard):

Voltage/Load

8 V/11.1 N·m (1.1 kgf-m, 8.2 ft-lb) or more

Current/Rotating speed

370 A/910 rpm or more

3) Lock test

With the starter stalled, or not rotating, measure the torque developed and current draw when the voltage is adjusted to standard voltage.

Lock test (standard):

Voltage/Current

3 V/750 A or less

Torque

15.5 N·m (1.6 kgf-m, 11.4 ft-lb) or more

4. OTHER INSPECTIONS

Check that the starter does not have deformation, cracks and any other damage.