

3. Generator

A: REMOVAL

1) Remove the V-belt covers.

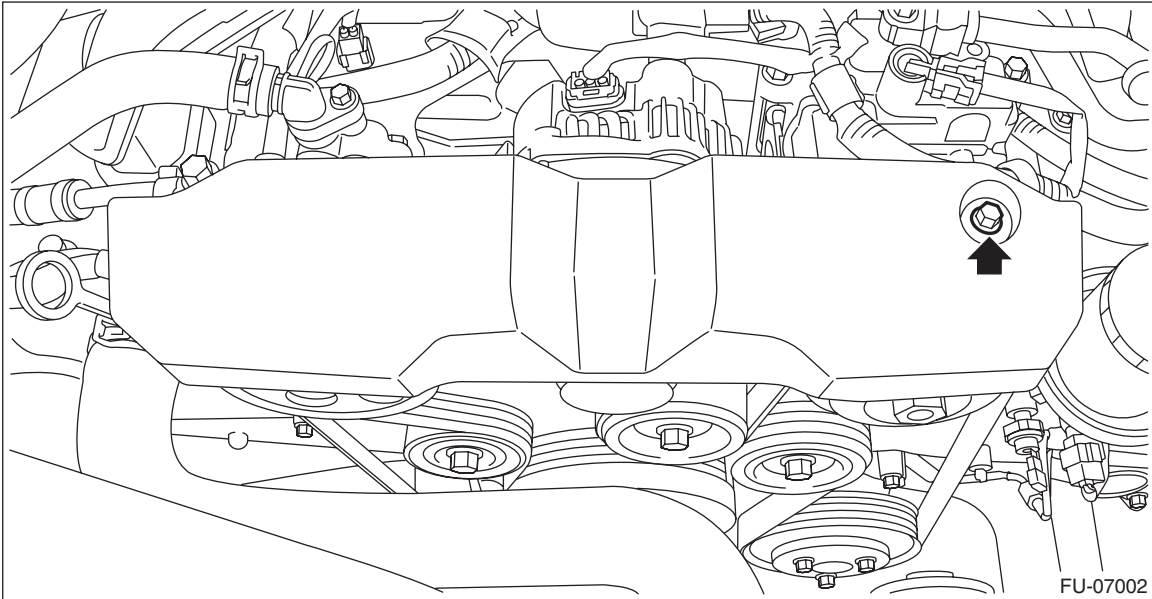

2) Disconnect the ground cable from battery.

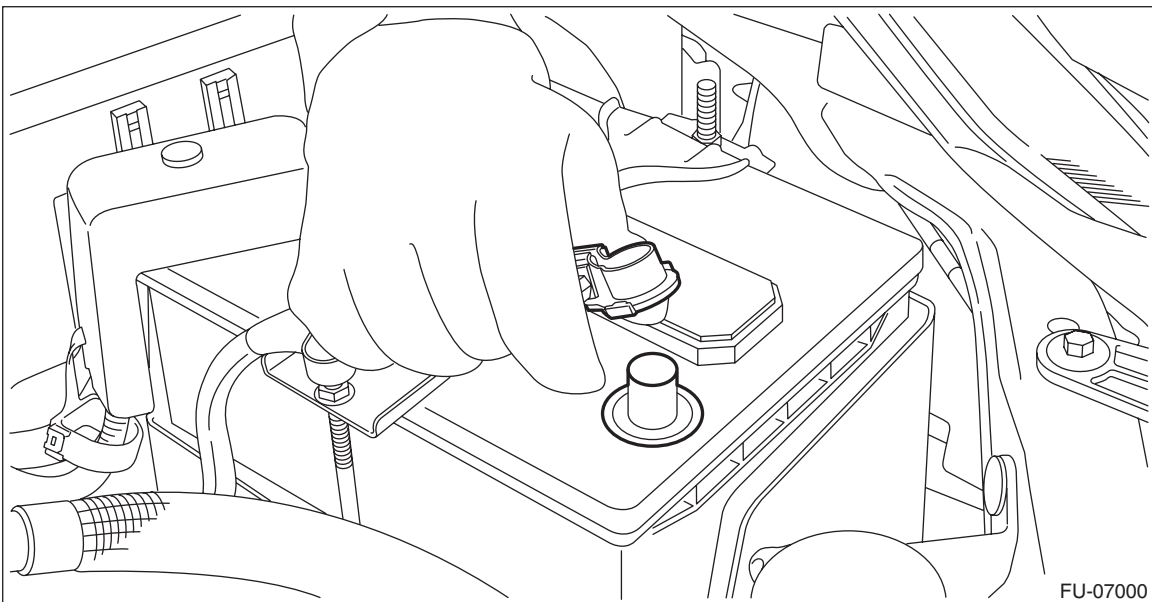

3) Remove the V-belts. <Ref. to ME(H4DO)-80, REMOVAL, V-belt.>

Generator

STARTING/CHARGING SYSTEMS

4) Remove the V-belt cover bracket.

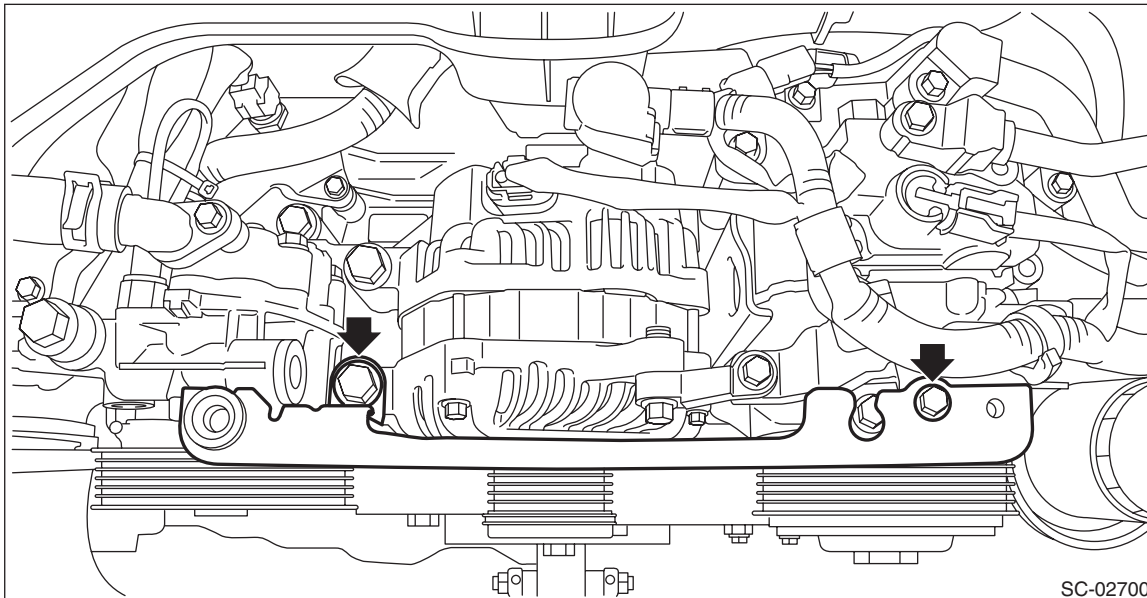

5) Disconnect the connector (A) and terminal (B) from the generator.

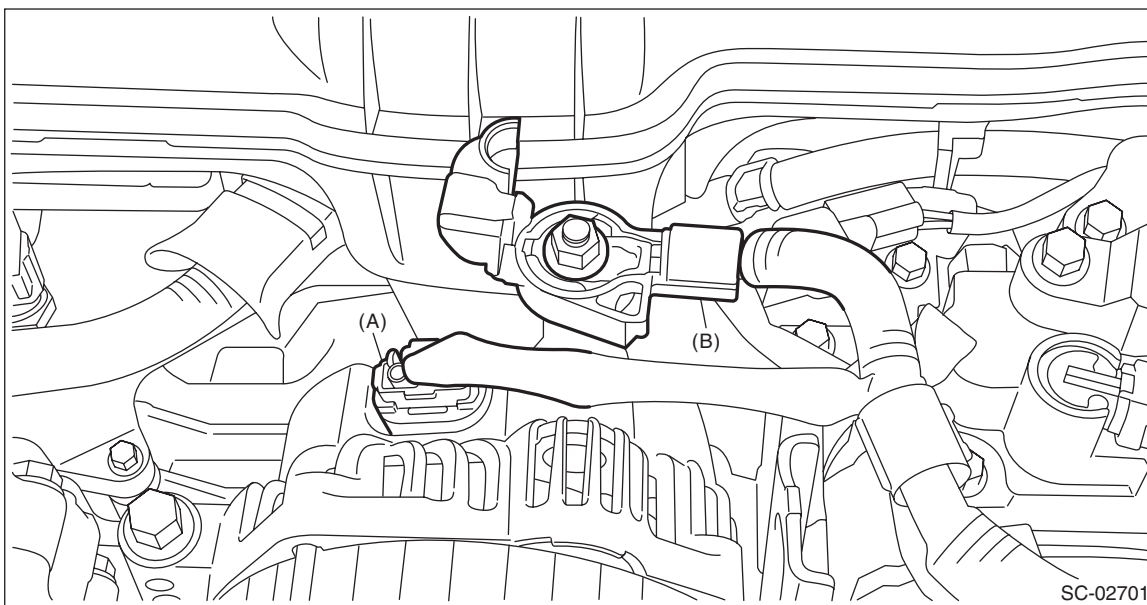

6) Remove the idler pulley from the chain cover.

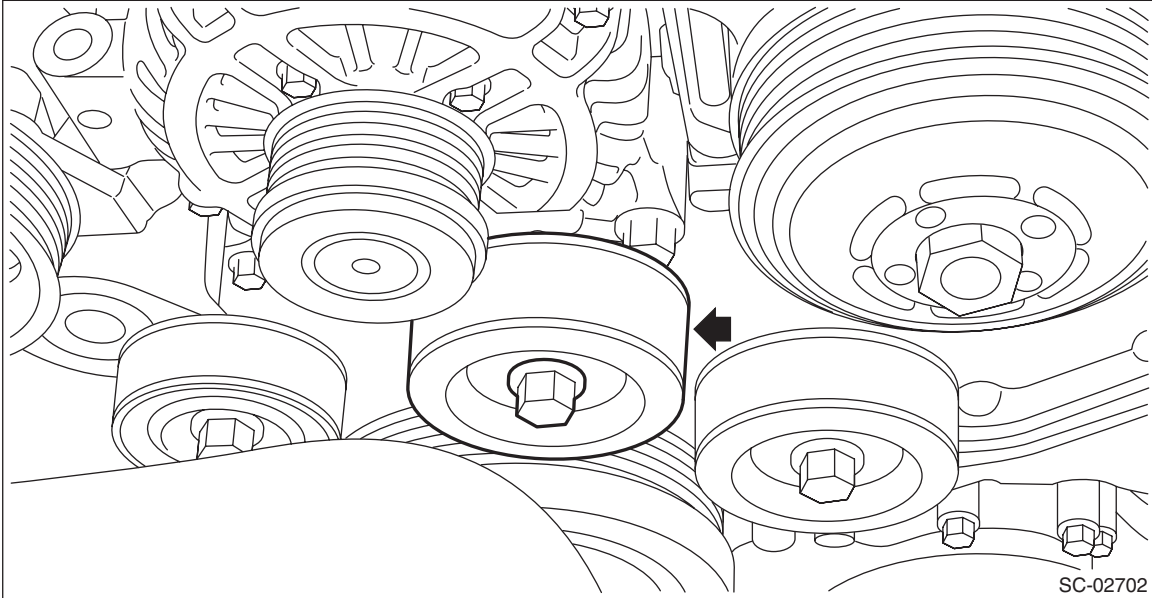

7) Remove the generator from the bracket.

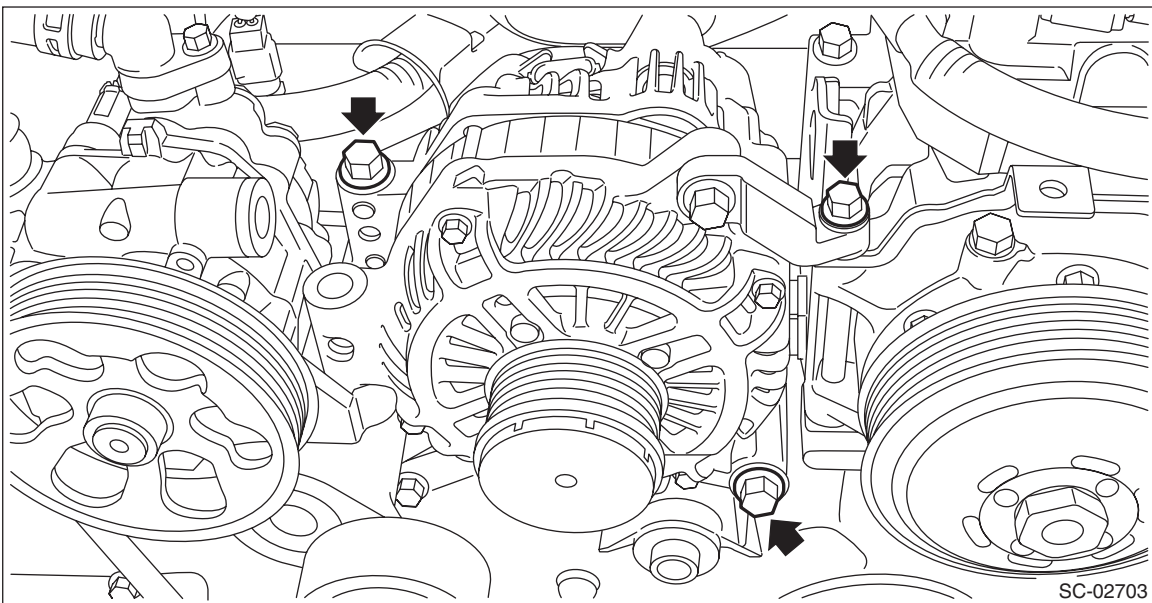

Generator

STARTING/CHARGING SYSTEMS

8) Remove the generator bracket from the generator.

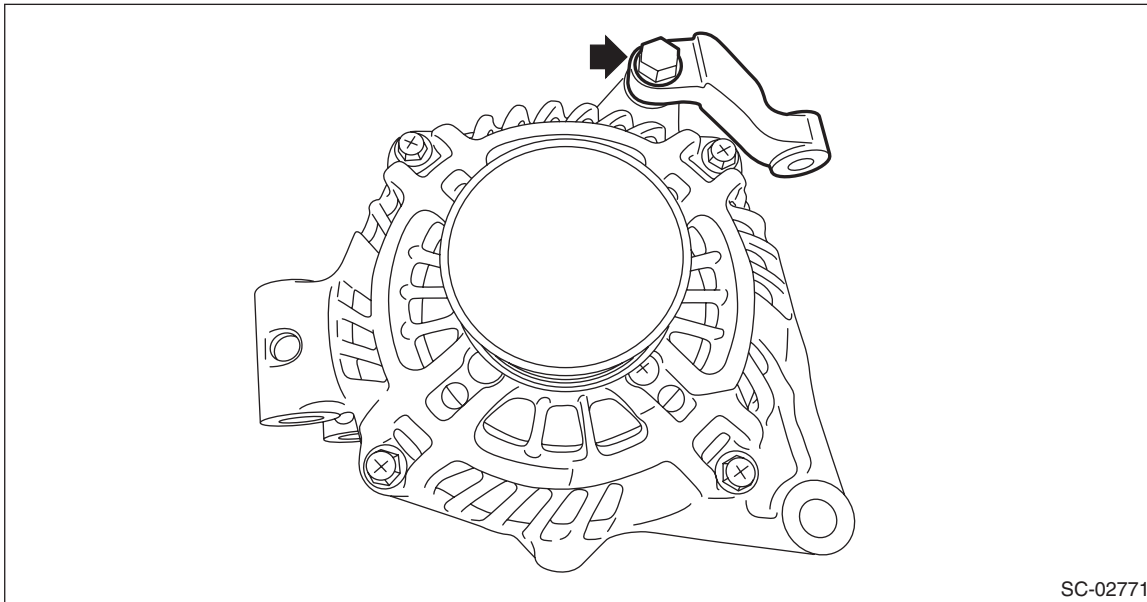

B: INSTALLATION

1) Temporarily install the generator bracket to the generator.

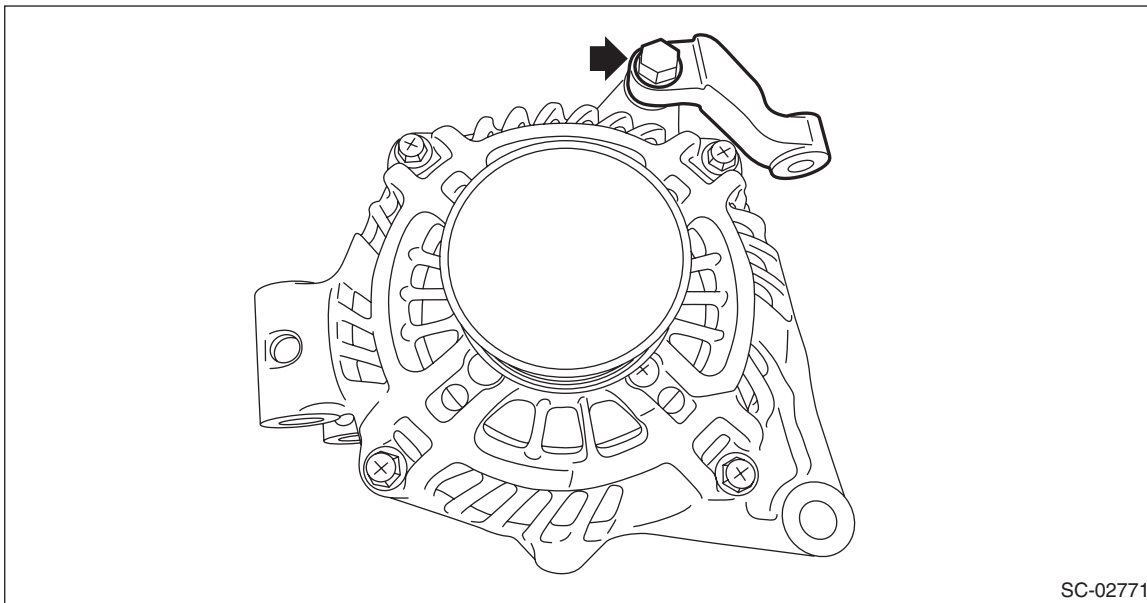

2) Temporarily install the generator to the engine.

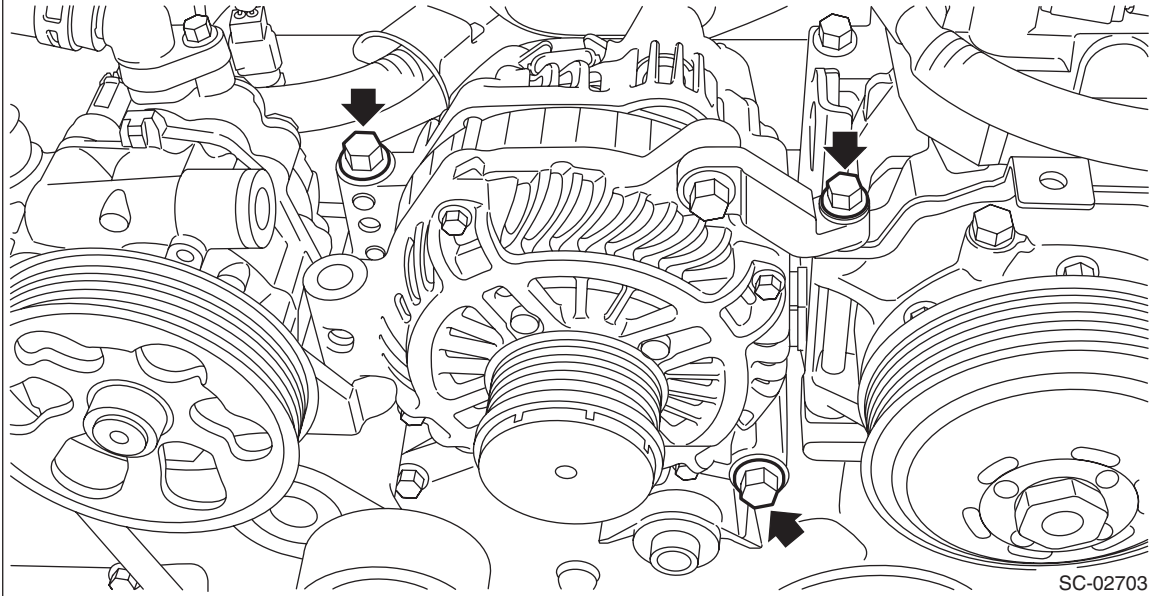

3) Tighten the generator and generator bracket in the numerical order.

Tightening torque:

T1: 25 N·m (2.5 kgf-m, 18.4 ft-lb)

T2: 36 N·m (3.7 kgf-m, 26.6 ft-lb)

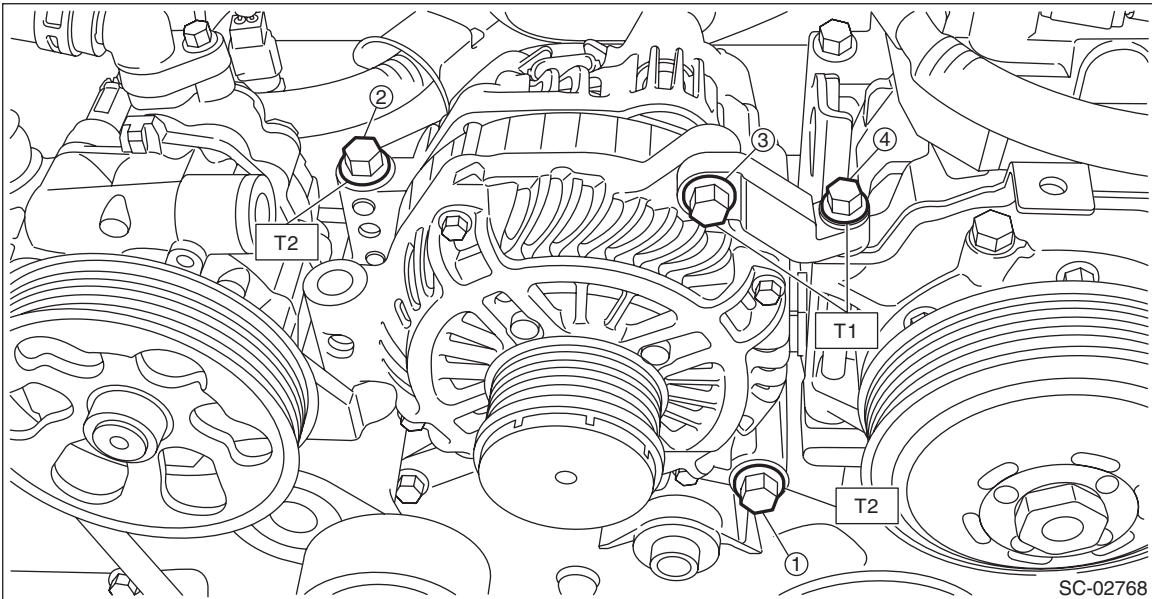

Generator

STARTING/CHARGING SYSTEMS

4) Install the V-belt cover bracket and tighten the bolts in the numerical order.

Tightening torque:

T1: 6.4 N·m (0.7 kgf-m, 4.7 ft-lb)

T2: 36 N·m (3.7 kgf-m, 26.6 ft-lb)

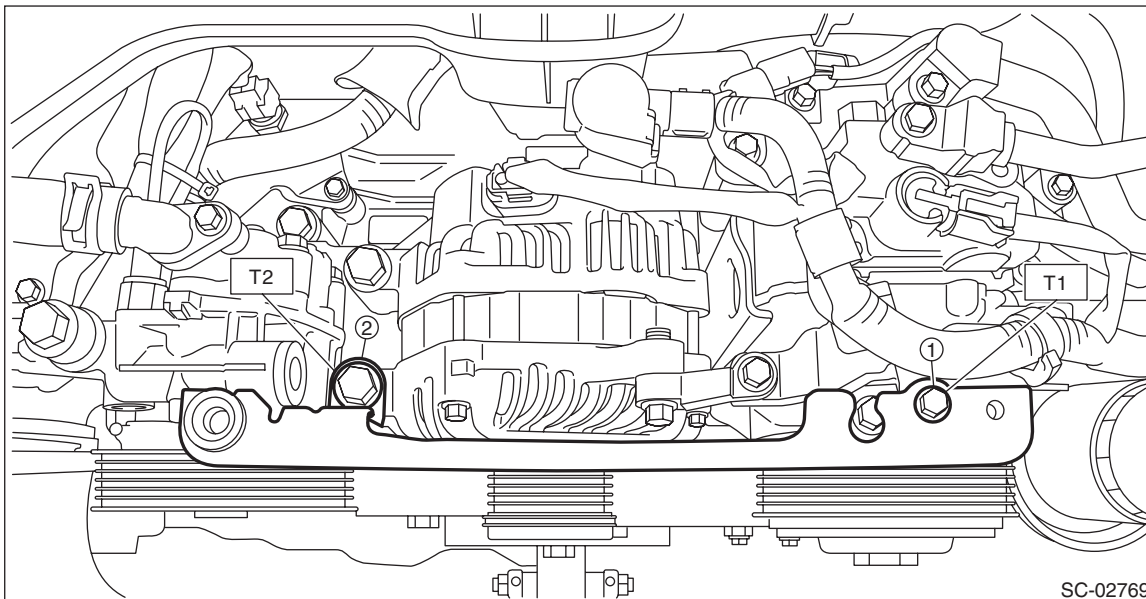

5) Install the idler pulley to the chain cover.

Tightening torque:

36 N·m (3.7 kgf-m, 26.6 ft-lb)

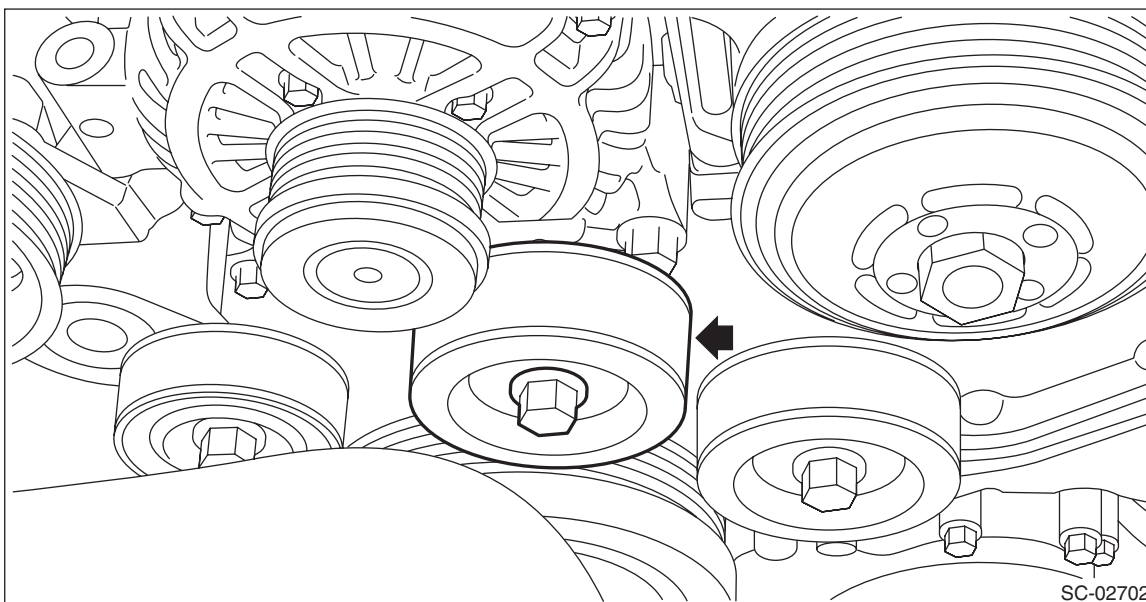

6) Connect the connector (A) and terminal (B) to the generator.

Tightening torque:

16 N·m (1.6 kgf-m, 11.8 ft-lb)

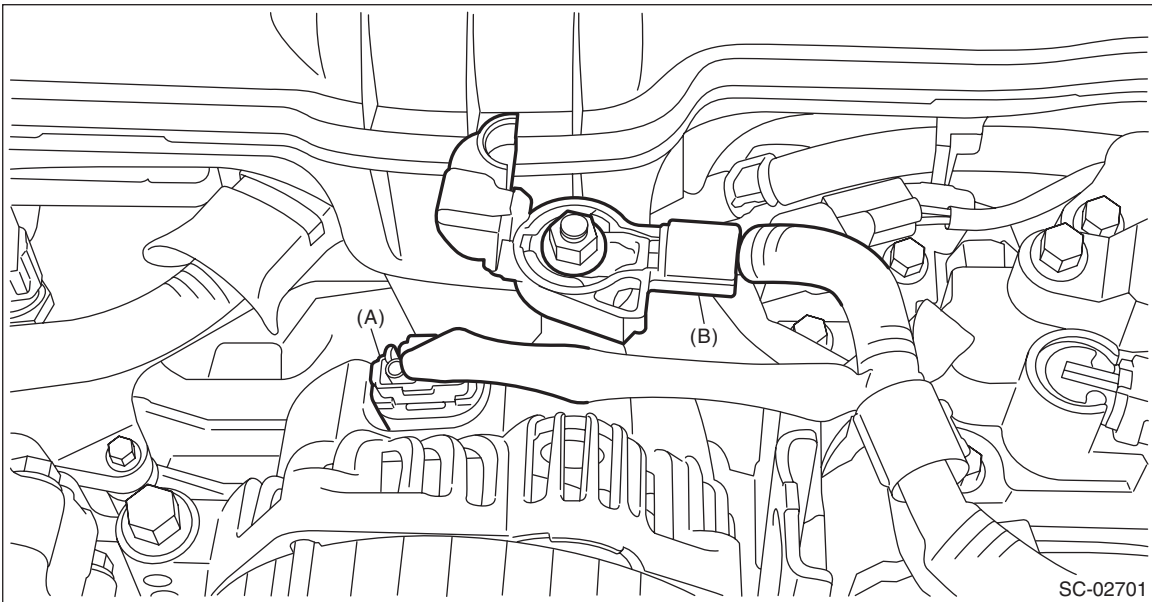

7) Install the V-belts. <Ref. to ME(H4DO)-82, INSTALLATION, V-belt.>

8) Connect the battery ground terminal.

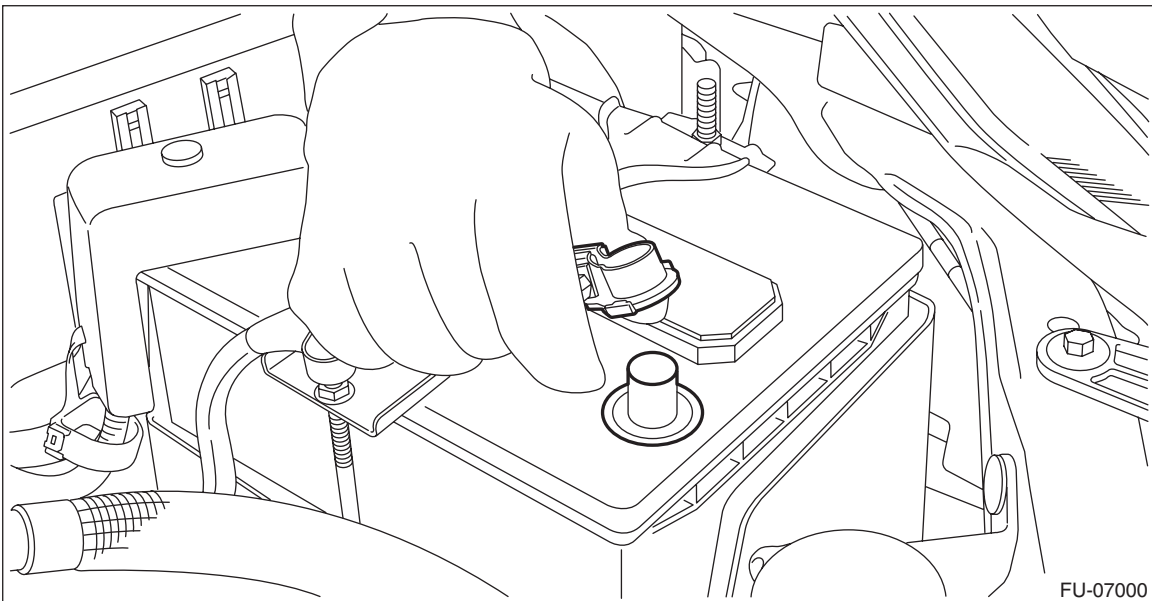

Generator

STARTING/CHARGING SYSTEMS

9) Install the V-belt cover.

Tightening torque:

6.4 N·m (0.7 kgf-m, 4.7 ft-lb)

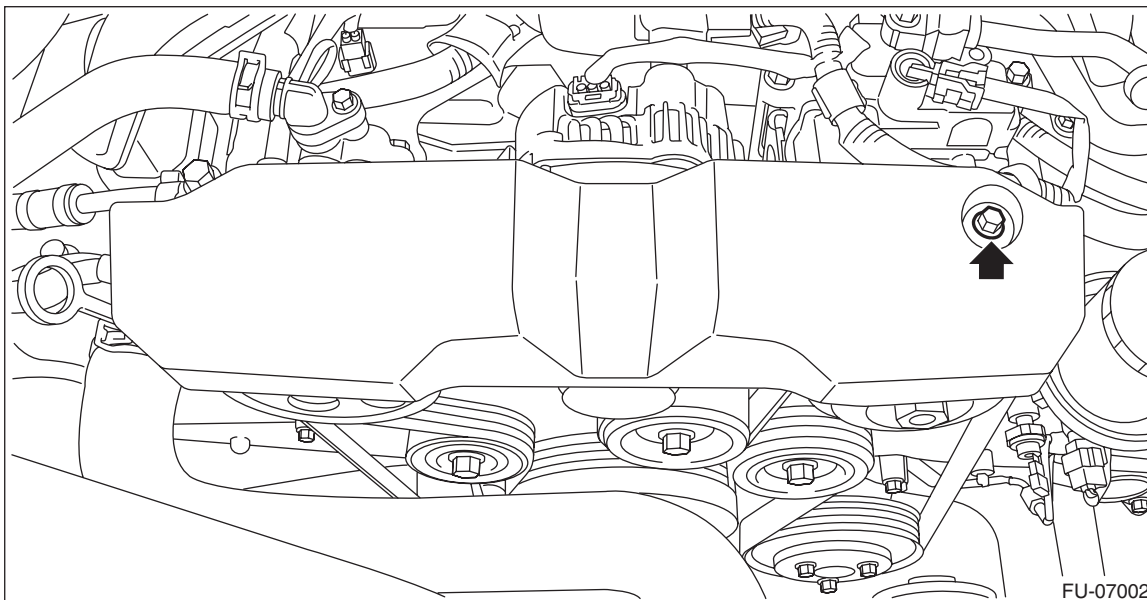

C: DISASSEMBLY

1) Remove the four through-bolts.

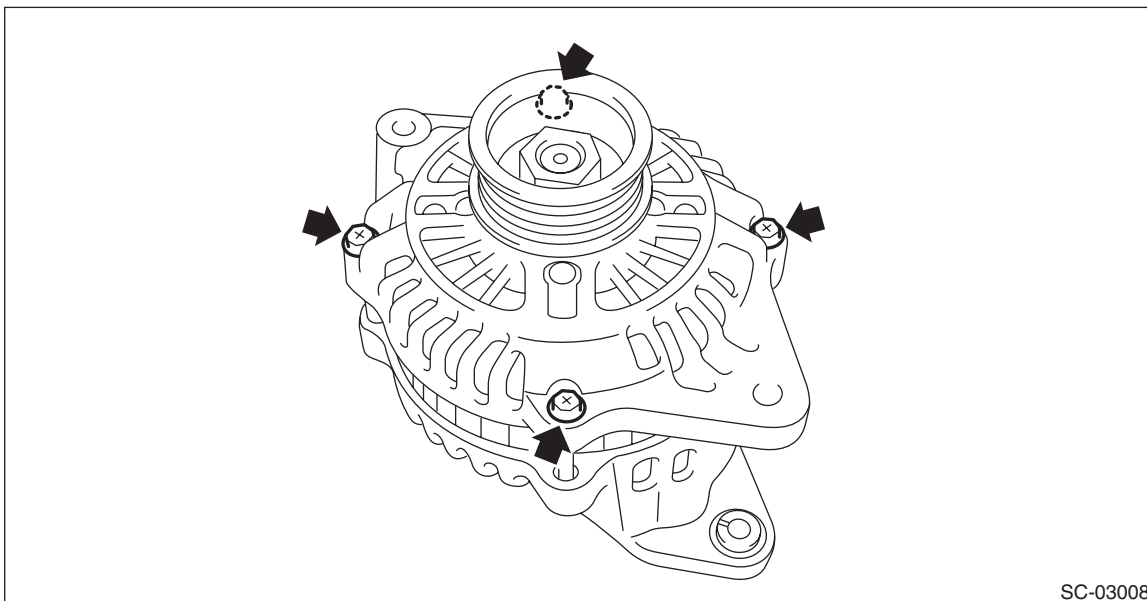

2) Use a drier to heat the rear cover (A) portion to 50°C (122°F).

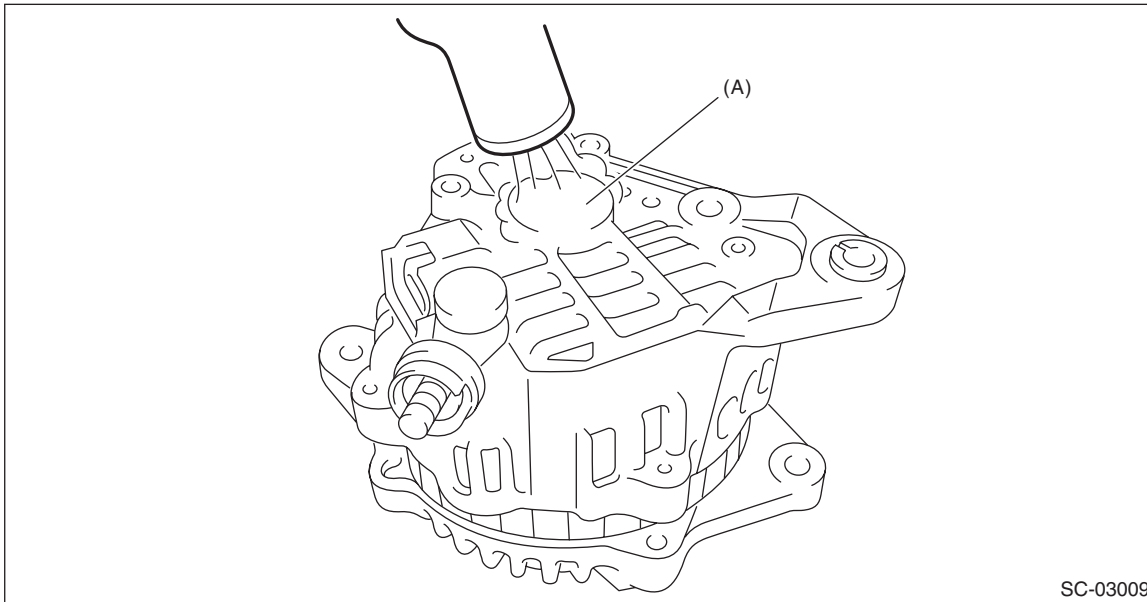

3) Insert the end of a flat tip screwdriver into the gap between stator core and front cover. Pry them apart to disassemble.

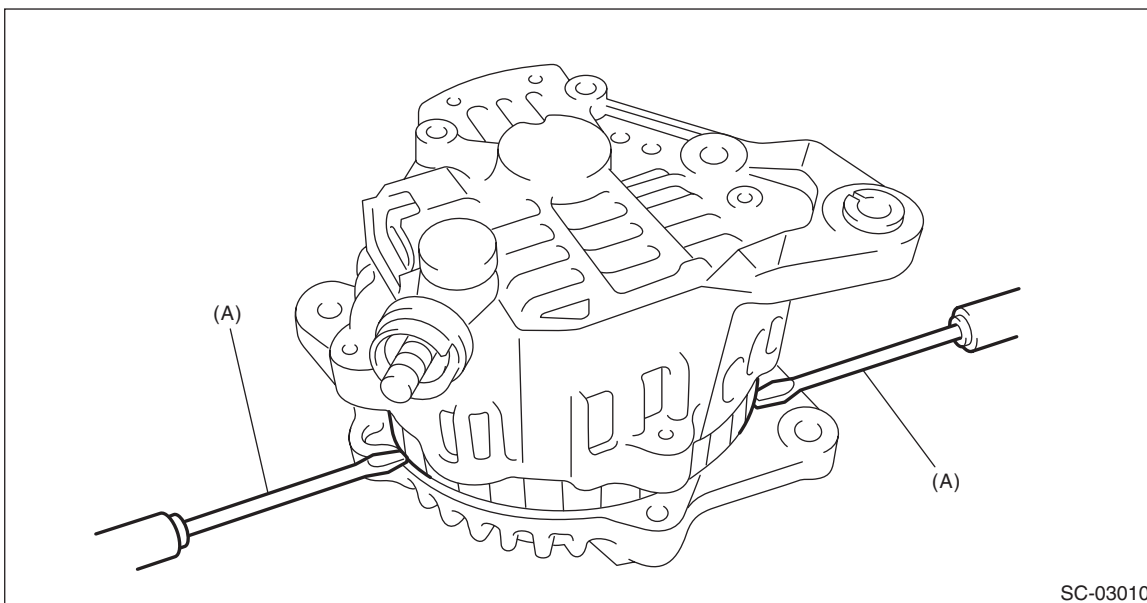

(A) Flat tip screwdriver

Generator

STARTING/CHARGING SYSTEMS

4) Hold the pulley with the ST, and turn the rotor side (hex bit socket) clockwise to remove the pulley.
ST 18366AA000 ADAPTER PULLEY

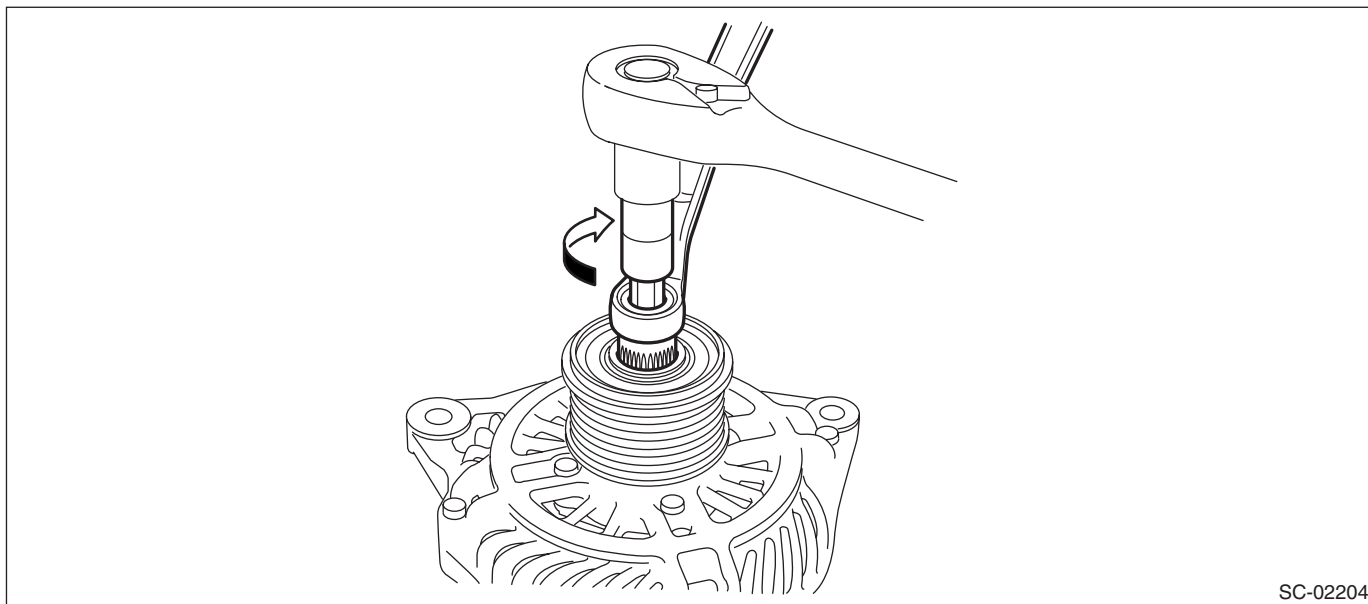

SC-02204

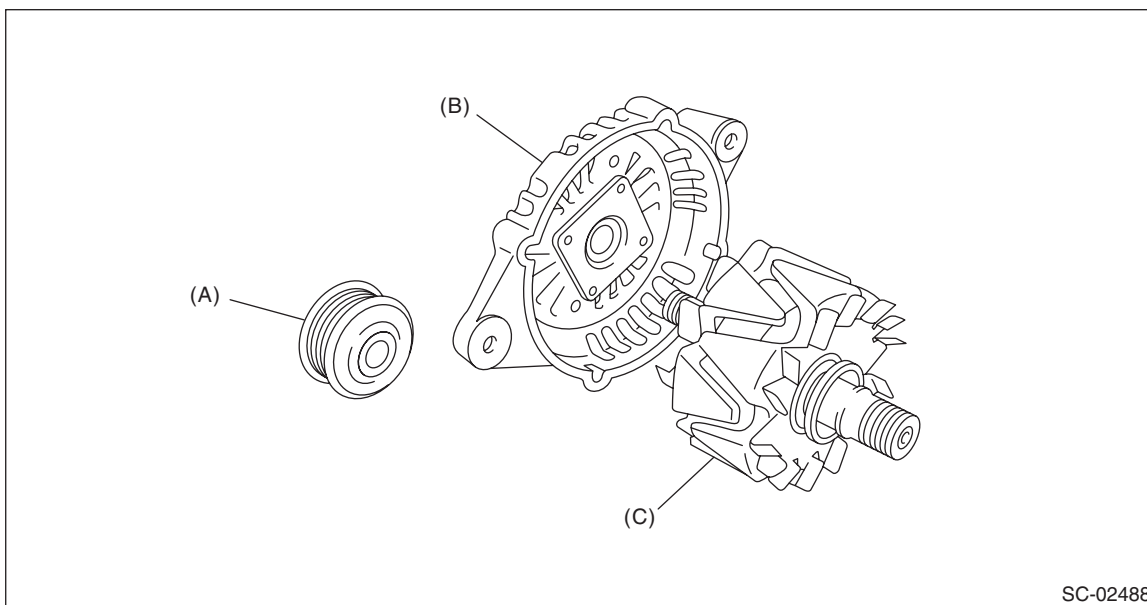

SC-02488

(A) Pulley

(B) Front cover

(C) Rotor

- 5) Use the following procedures to remove the ball bearings.
- (1) Remove the bolt, and then detach the bearing retainer.

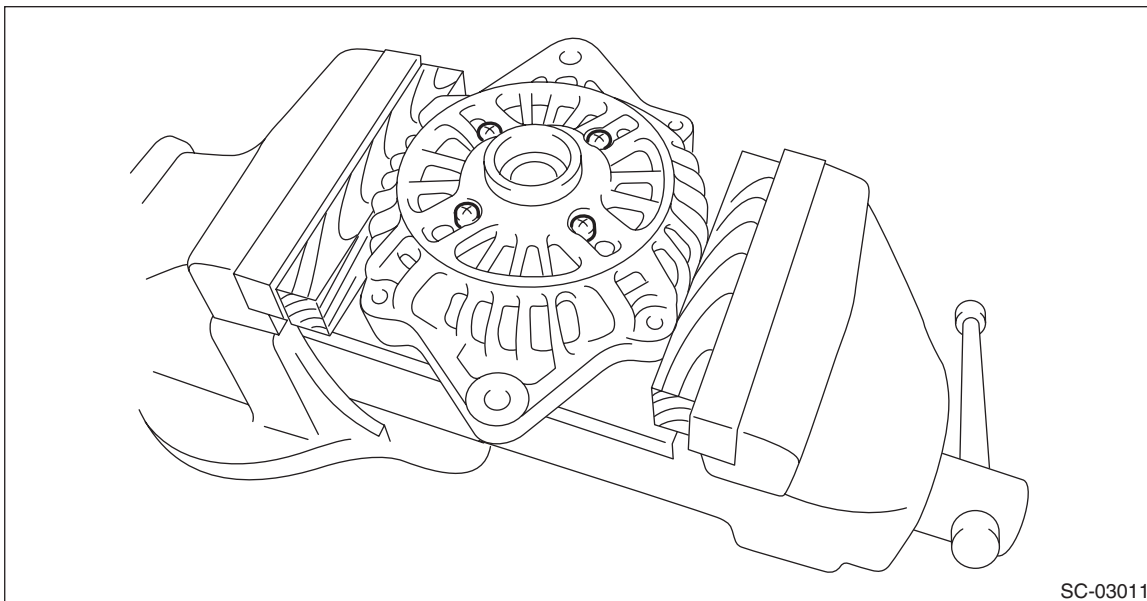

- (2) Firmly attach an appropriate tool (such as a correct size socket wrench) to the bearing inner race.

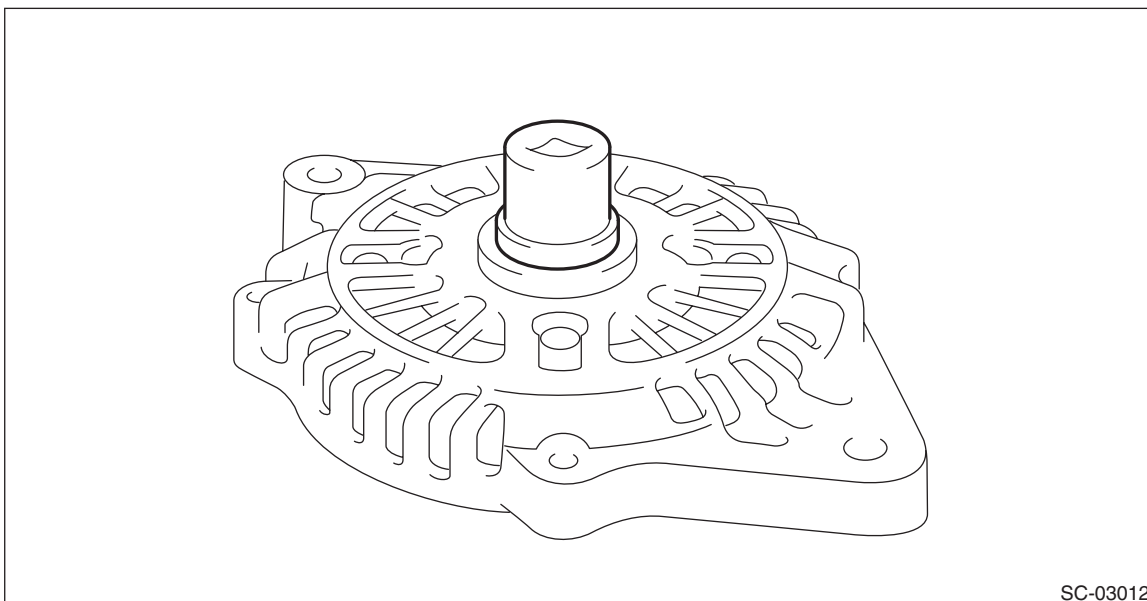

- (3) Use the press to push the ball bearings out from the front cover.

Generator

STARTING/CHARGING SYSTEMS

6) Using the bearing puller, remove the bearings from the rotor.

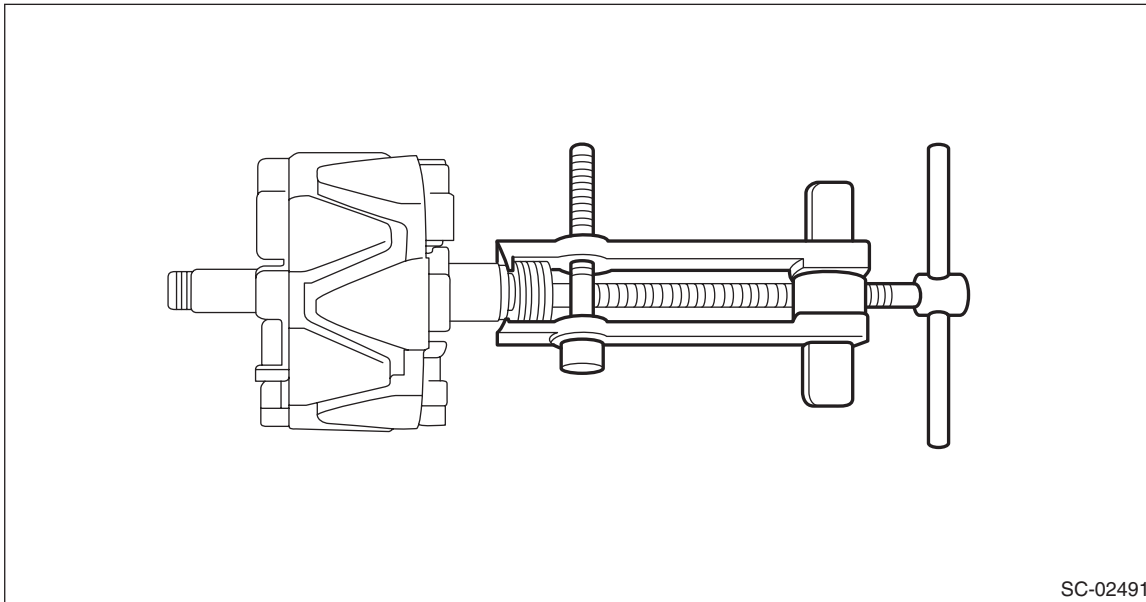

7) Disconnect the connection between the rectifier and stator coil, then remove the stator coil.

CAUTION:

The rectifier is easily damaged by heat. Do not allow a 180 — 270 W soldering iron to contact the terminals for 5 seconds or more at a time.

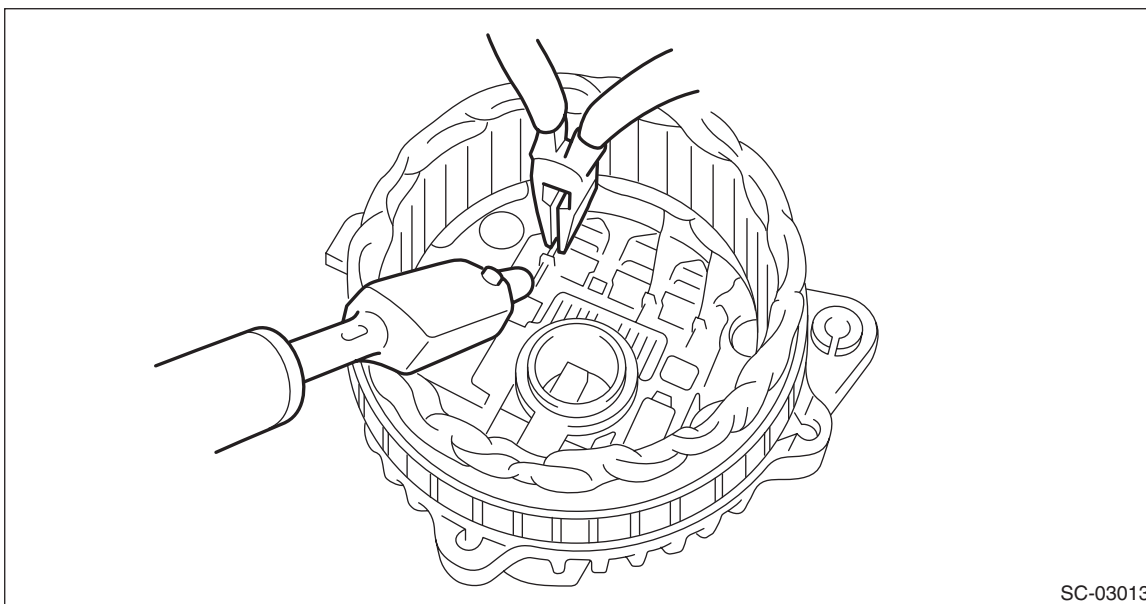

- 8) Use the following procedures to remove the IC regulator.
- (1) Remove the screws which secure the IC regulator to the rear cover.

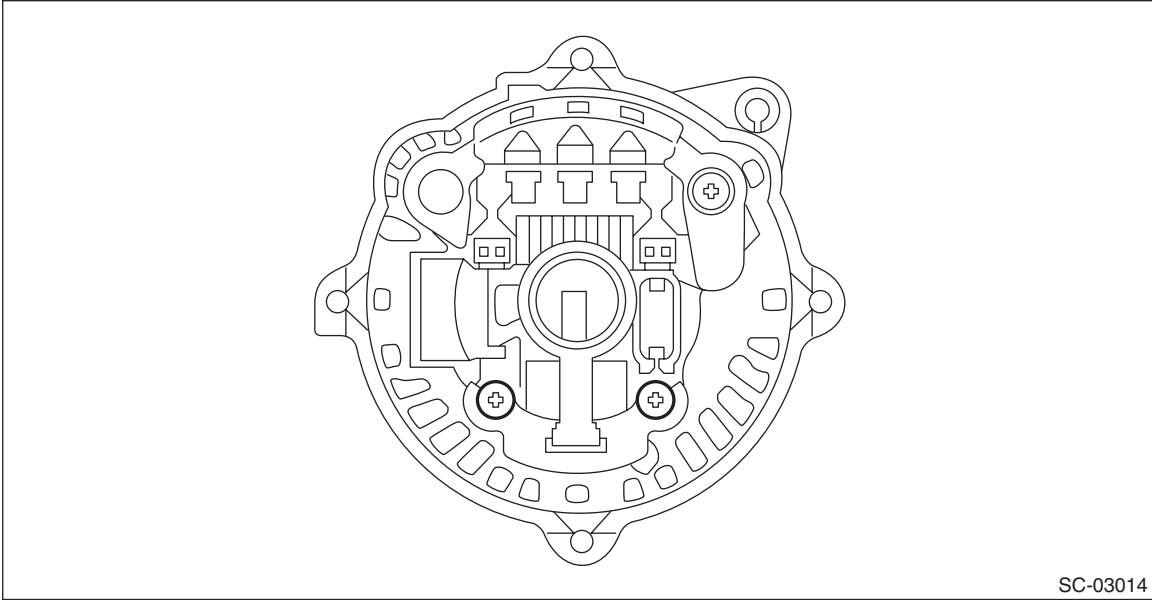

- (2) Disconnect the connection between the IC regulator and rectifier, then remove the IC regulator.

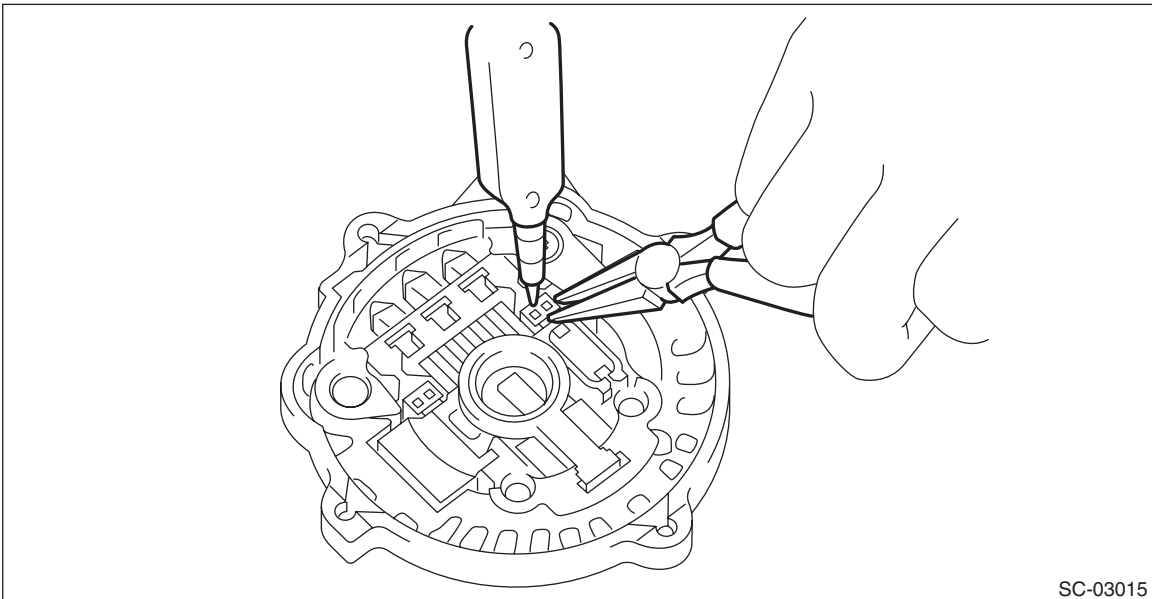

Generator

STARTING/CHARGING SYSTEMS

9) Use the following procedures to remove the brush.

(1) Remove the cover A.

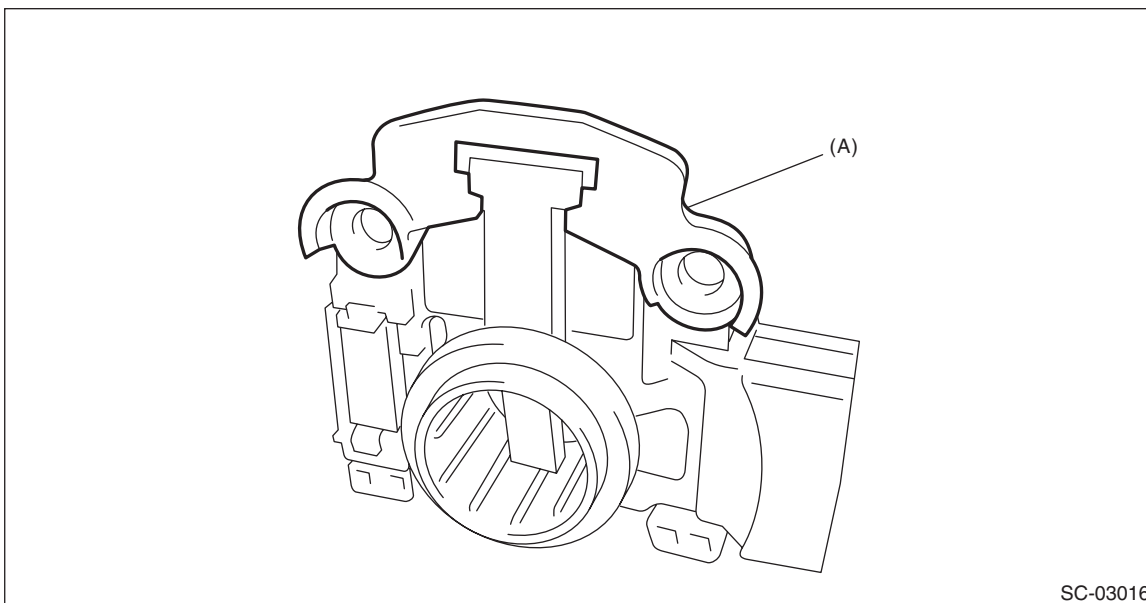

SC-03016

(A) Cover A

(2) Remove the cover B.

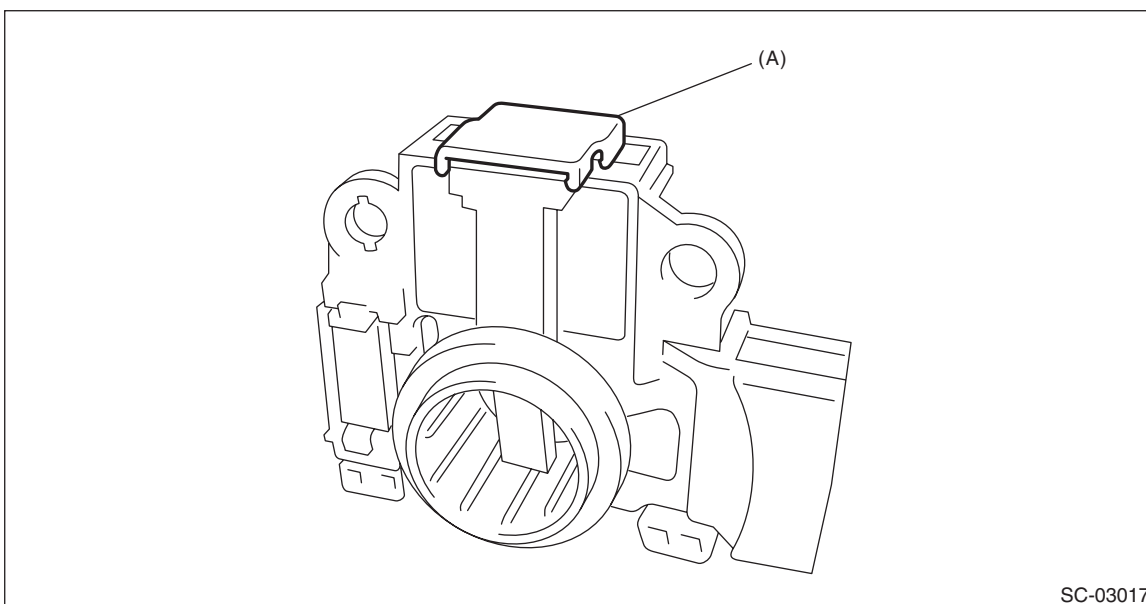

SC-03017

(A) Cover B

- (3) Disconnect the connection and remove the brush.

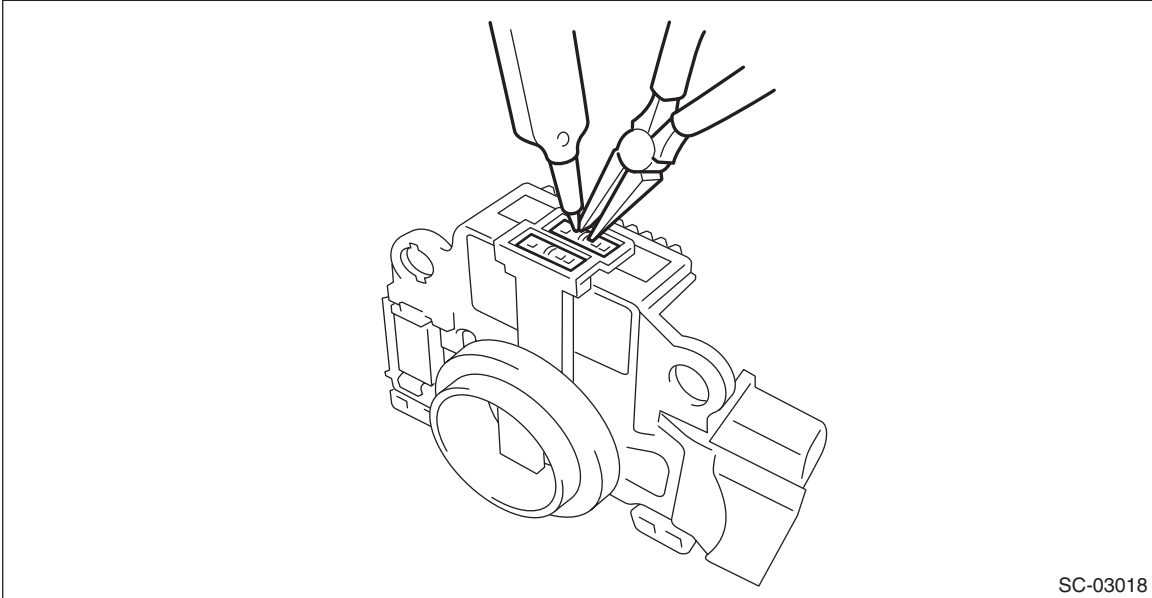

- 10) Remove the rectifier as follows.

- (1) Remove the bolts which secure the rectifier.

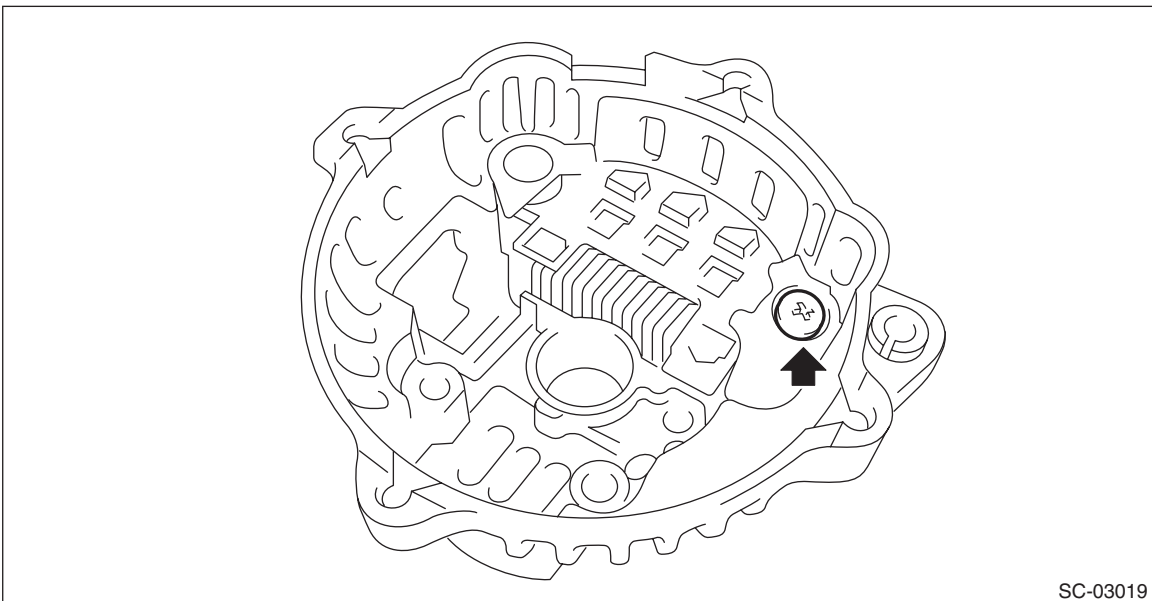

Generator

STARTING/CHARGING SYSTEMS

- (2) Remove the cover on terminal B.

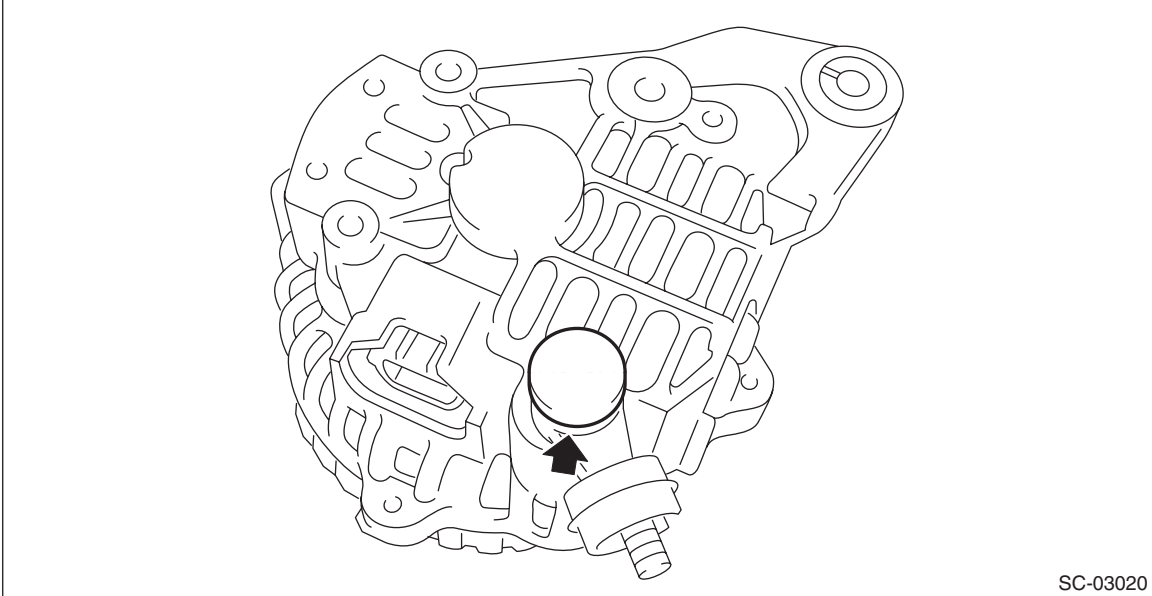

- (3) Remove the nuts of terminal B, then remove the rectifier.

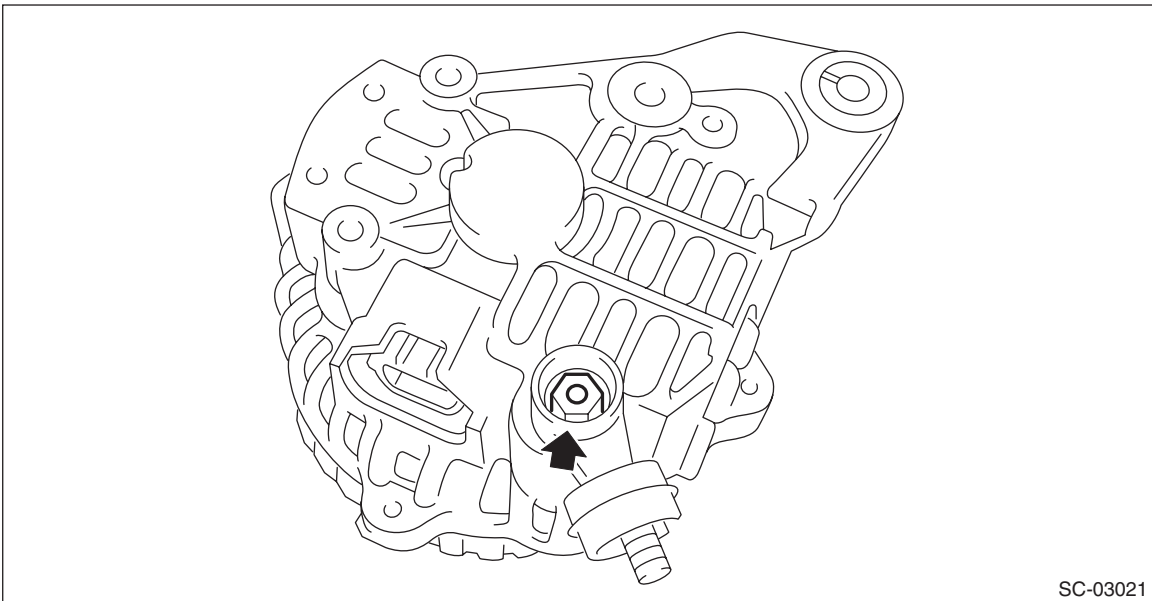

D: ASSEMBLY

Assemble in the reverse order of disassembly.

NOTE:

- Refer to component for tightening torque of each part. <Ref. to SC(H4DO)-4, GENERATOR, COMPONENT, General Description.>
- After assembling, manually turn the pulley to check that the rotor rotates smoothly.

1) Push of the brush

Before assembling the front and rear parts, press the brush down into the brush holder, then fix the brush in that position by inserting a [1 mm (0.04 in) dia., 40 — 50 mm (1.6 — 2.0 in) long] wire through the hole as shown in the figure.

CAUTION:

After re-assembling, remove the wire.

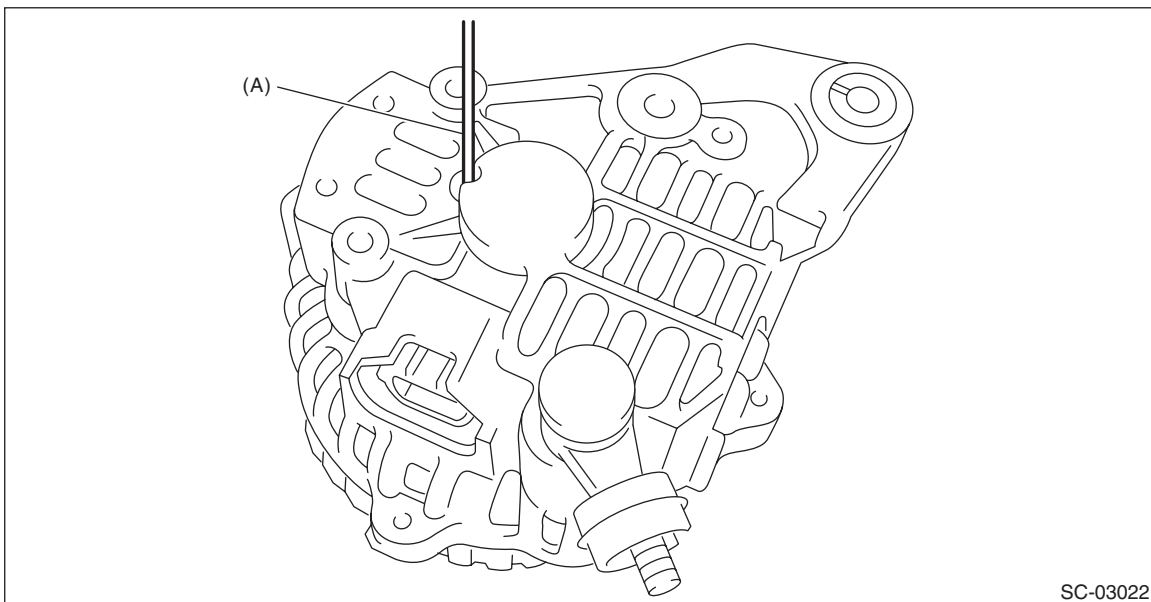

(A) Wire

2) Install the ball bearings.

- (1) Set the ball bearings in the front cover, then securely install an appropriate tool (such as a socket wrench of proper size) to the bearing outer race.
 - (2) Using a press to press the ball bearings into the specified location.
 - (3) Install the bearing retainer.
- 3) Use a press to install the bearings (rear side) to the rotor shaft.
- 4) Heat the bearing box in rear cover to 50 — 60°C (122 — 140°F), and then press the rear bearing into rear cover.

CAUTION:

Do not apply grease to the rear bearings. If there is any oil on the bearing box, remove it completely.

Generator

STARTING/CHARGING SYSTEMS

E: INSPECTION

1. DIODE

CAUTION:

There is the possibility of damaging the diodes if a mega-tester (used to measure high voltages) or a similar measuring instrument is used. Never use a mega tester or equivalent for this test.

1) Check for continuity between the diode lead and positive side heat sink. If resistance is 1Ω or more only in the direction from the diode lead to the heat sink, replace the rectifier.

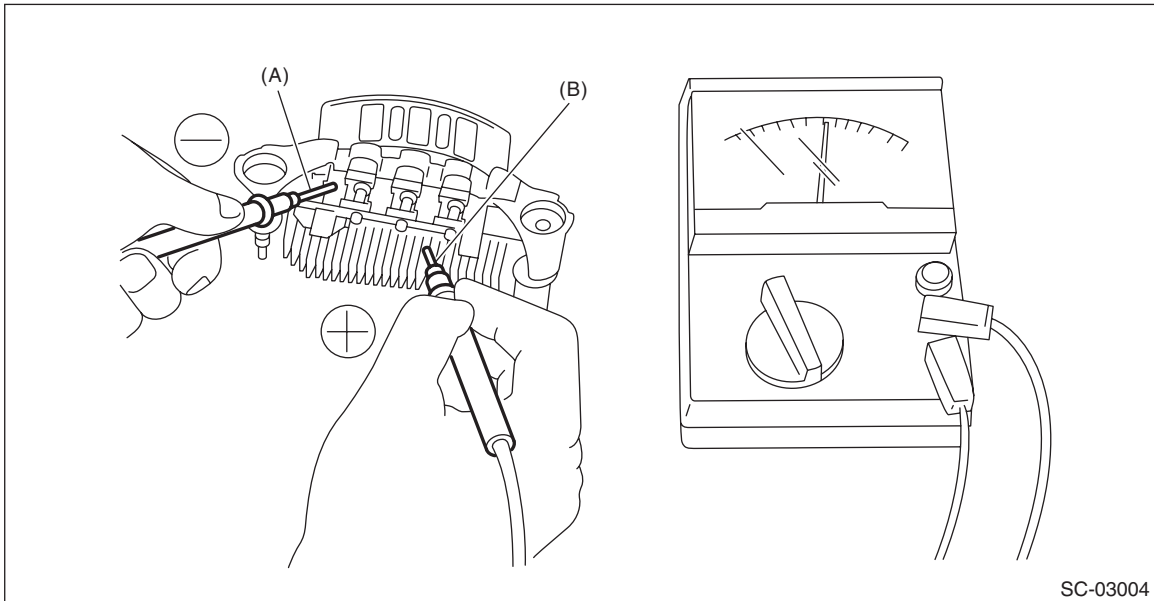

(A) Diode lead

(B) Heat sink (positive side)

2) Check for continuity between the negative side heat sink and diode lead. If resistance is 1Ω or more only in the direction from the heat sink to the diode lead, replace the rectifier.

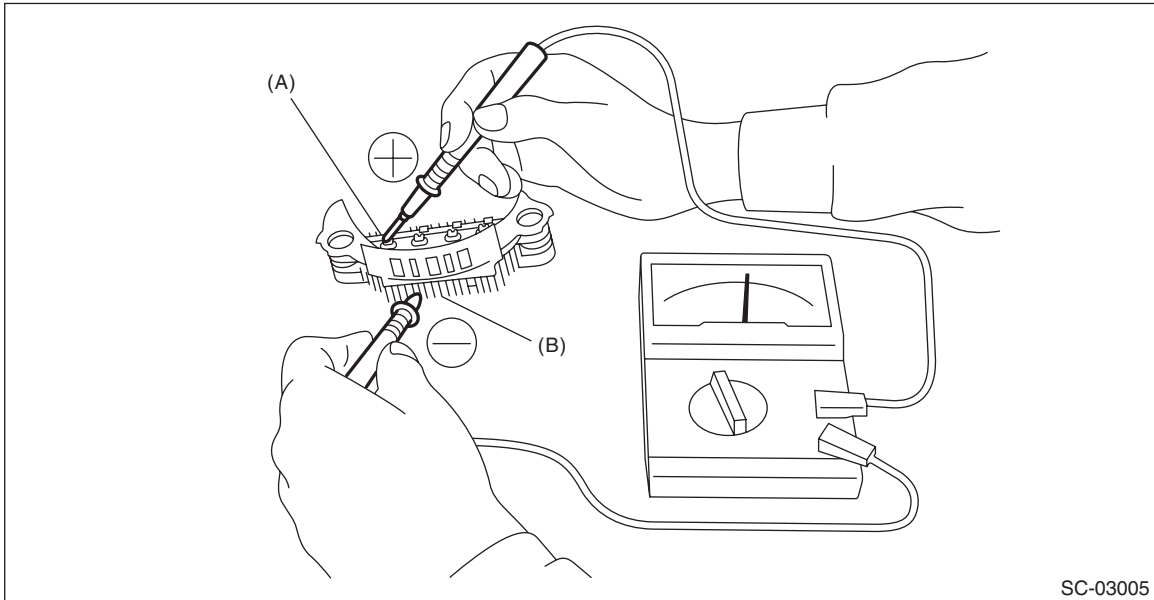

(A) Diode lead

(B) Heat sink (negative side)

2. ROTOR

- 1) Inspect the slip rings for contamination or any roughness on the sliding surface. Repair the slip ring surface using a lathe or sand paper.
- 2) Measure the slip ring outer diameter. Replace the rotor if the slip ring is worn.

Slip ring outer diameter:

Standard

22.7 mm (0.894 in)

Limit

22.1 mm (0.870 in)

- 3) Using a circuit tester, check the resistance between slip rings. If resistance exceeds the standard, replace the rotor.

Standard:

Approx. 1.8 — 2.2 Ω

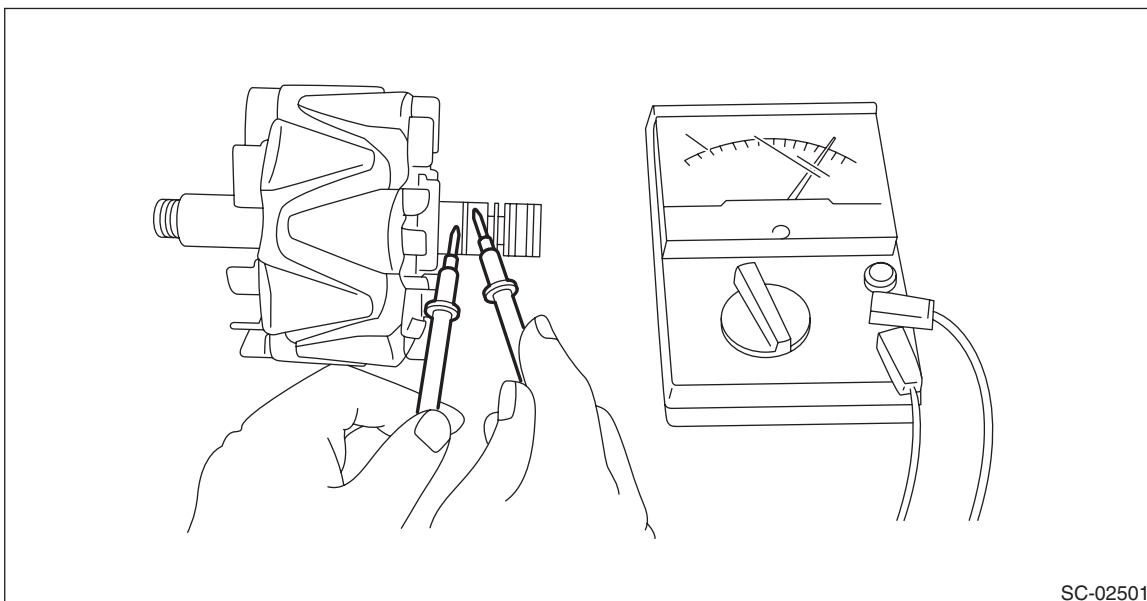

- 4) Check the continuity between slip ring and rotor core or shaft. If there is continuity, replace the rotor because the rotor coil is grounded.

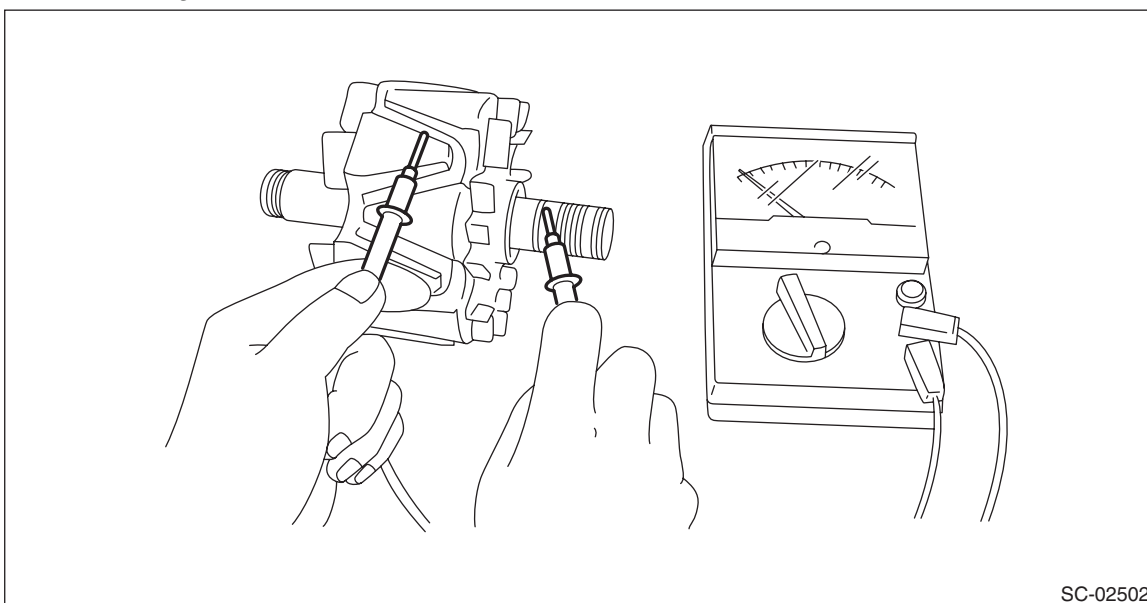

- 5) Check the ball bearings. If there is any noise, or the rotor does not rotate smoothly, replace the bearings.

Generator

STARTING/CHARGING SYSTEMS

3. STATOR COIL

1) Inspect continuity between the stator coil lead wire terminals. If the resistance is $1\text{ M}\Omega$ or more, replace the stator coil.

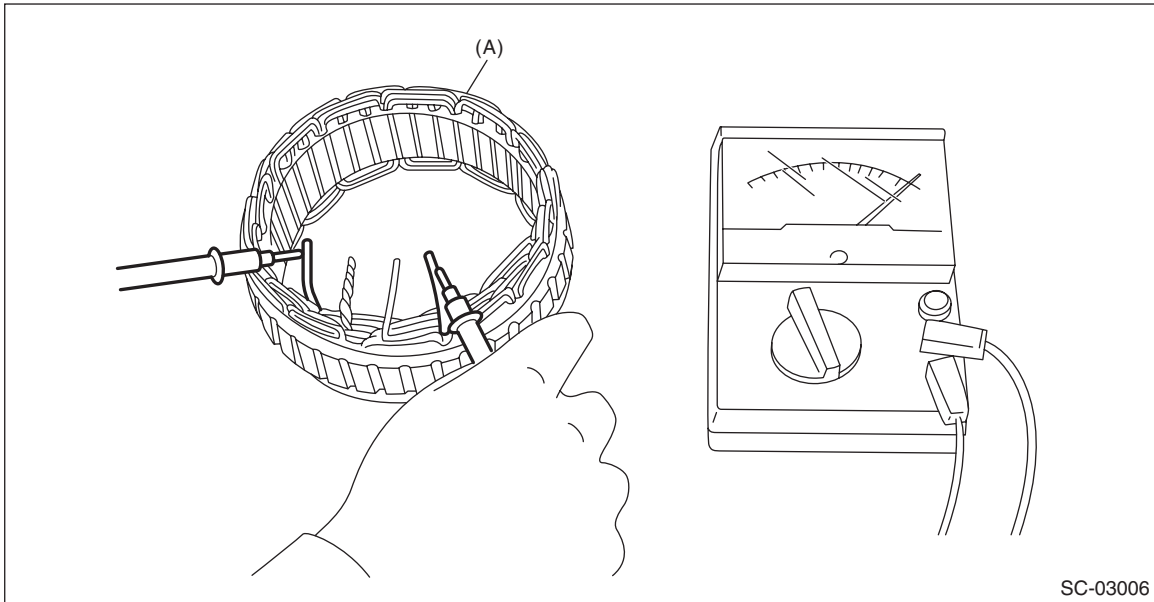

(A) Stator

2) Inspect the continuity between the stator coil stator core and lead wire terminals. If the resistance is $1\ \Omega$ or less, replace the stator coil.

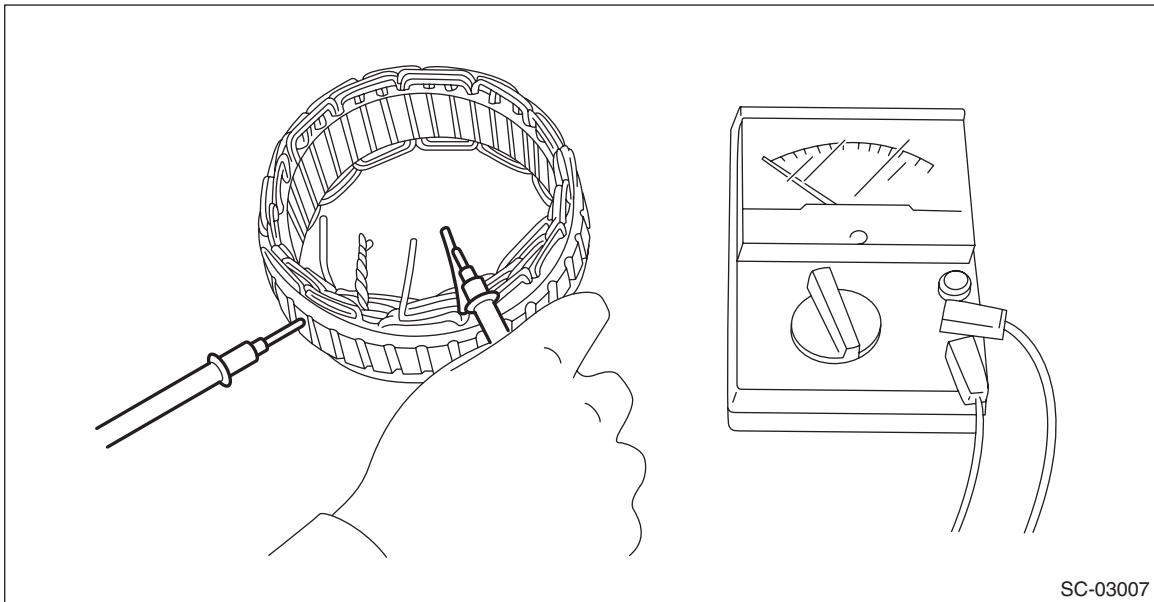

4. BRUSH

1) Measure the length of each brush. Replace the brush if wear exceeds service limits. There is a service limit mark (A) on each brush.

Brush length:

Standard (1)

18.5 mm (0.728 in)

Limit (2)

5.0 mm (0.197 in)

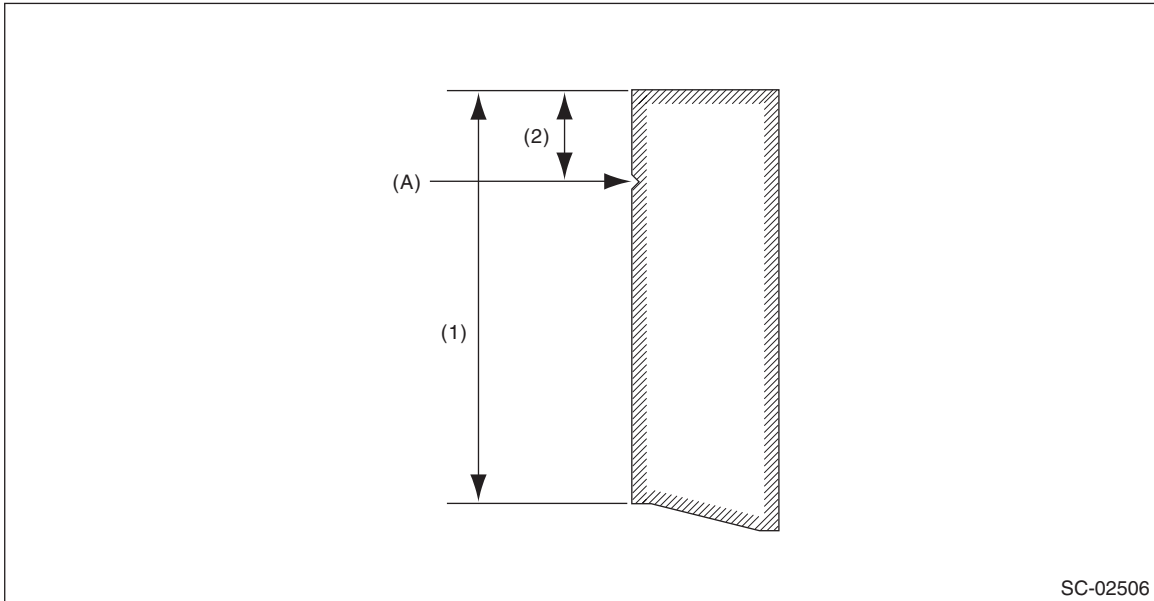

2) Using a spring pressure indicator, push the brush into the brush holder until its tip protrudes 2 mm (0.08 in). Then measure the pressure of brush spring. If the pressure is 2.648 N (270 g, 9.52 oz) or less, replace the brush spring with a new part. 4.609 — 5.786 N (470 — 590 g, 16.58 — 20.810 oz) pressure is required on the new spring.

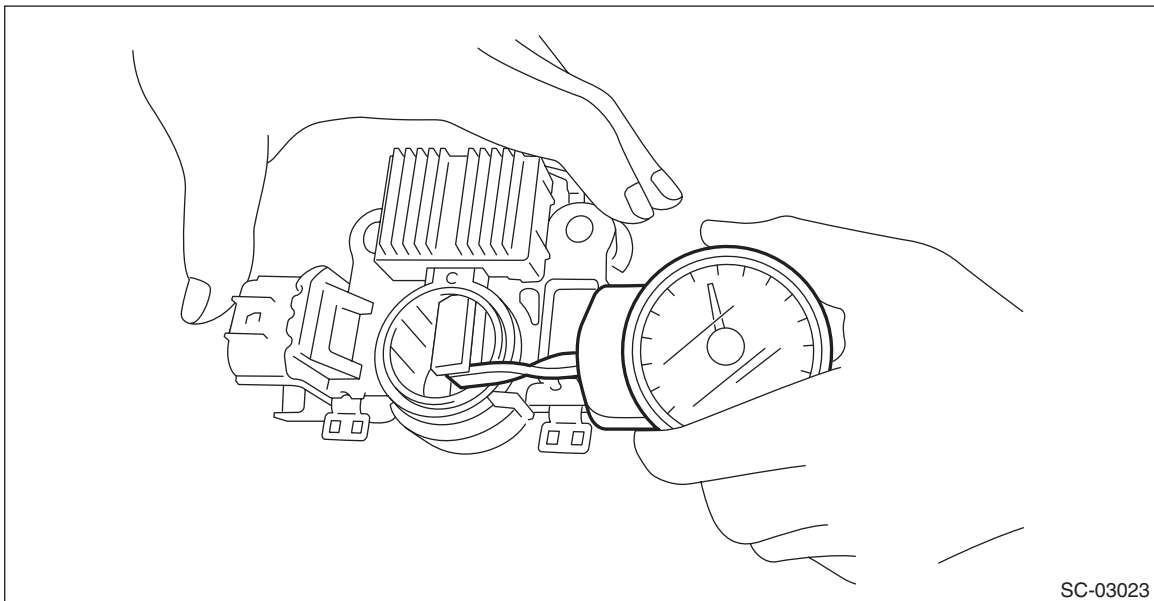

Generator

STARTING/CHARGING SYSTEMS

5. BALL BEARING

Check the ball bearings. Replace the ball bearings if there is resistance in the rotation, or if there is any abnormal noise.

6. OTHER INSPECTIONS

Check that the generator does not have deformation, cracks and any other damage.