

## 8. Radiator Main Fan and Fan Motor

### A: REMOVAL

1) Remove the collector cover.

**NOTE:**

Follow the steps below when removing the collector cover.

- (1) Pull up the two points at the rear (A).
- (2) Pull up the two points at the front (B) while moving them forward.

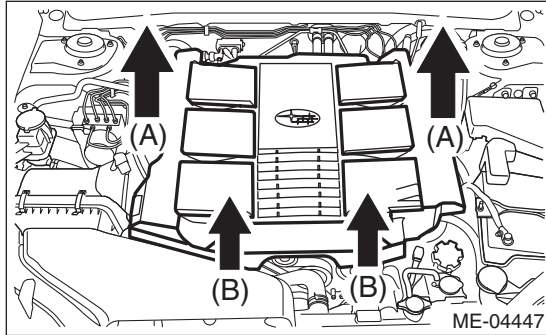

- 2) Disconnect the ground cable from battery.
- 3) Lift up the vehicle.
- 4) Remove the under cover. <Ref. to EI-33, REMOVAL, Front Under Cover.>
- 5) Drain engine coolant. <Ref. to CO(H6DO)-12, DRAINING OF ENGINE COOLANT, REPLACEMENT, Engine Coolant.>
- 6) Disconnect the integrated connector of radiator main fan & fan motor and radiator sub fan & fan motor.

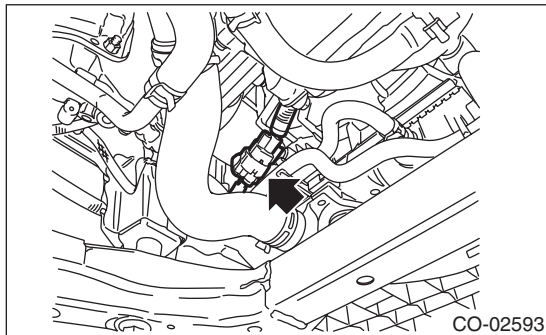

- 7) Lower the vehicle.
- 8) Remove the air intake duct. <Ref. to IN(H6DO)-8, REMOVAL, Air Intake Duct.>
- 9) Remove the grille bracket.

**NOTE:**

Remove ten clips when removing the grille bracket.

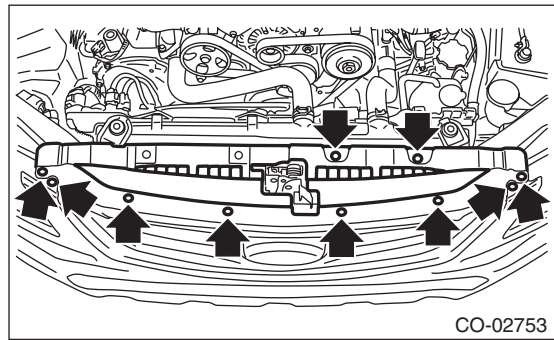

- 10) Remove the reservoir tank. <Ref. to CO(H6DO)-25, REMOVAL, Reservoir Tank.>
- 11) Remove radiator inlet hoses LH and RH only on radiator side.

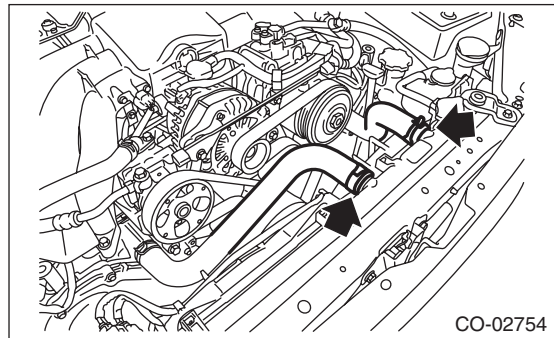

- 12) Remove the ATF radiator hose from the clip of the radiator fan shroud.
- 13) Remove bolts on the upper side of radiator fan shroud.

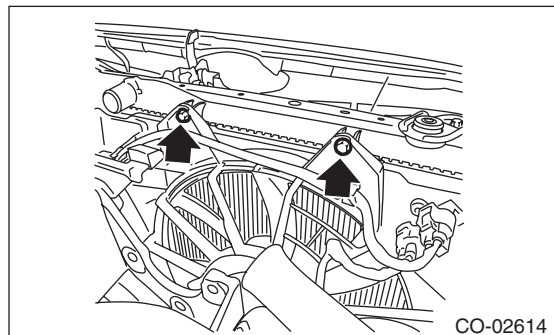
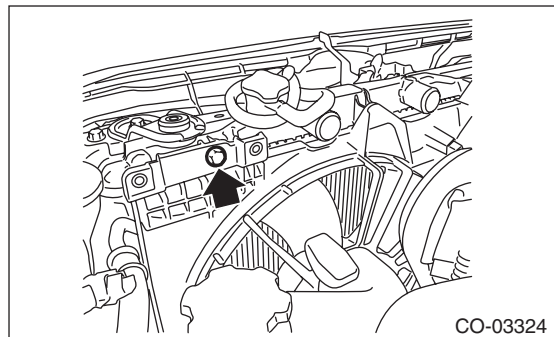

- 14) Remove the radiator fan shroud.

**NOTE:**

When pulling up the radiator fan shroud, be careful not to damage the radiator hose or ATF radiator hose.

# Radiator Main Fan and Fan Motor

## COOLING

### B: INSTALLATION

1) Tighten the bolts on the upper side of radiator fan shroud.

#### Tightening torque:

**7.5 N·m (0.8 kgf·m, 5.5 ft·lb)**

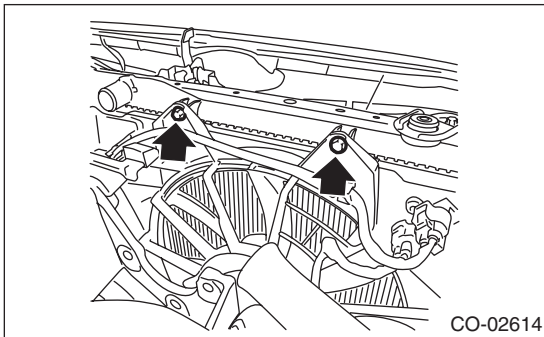
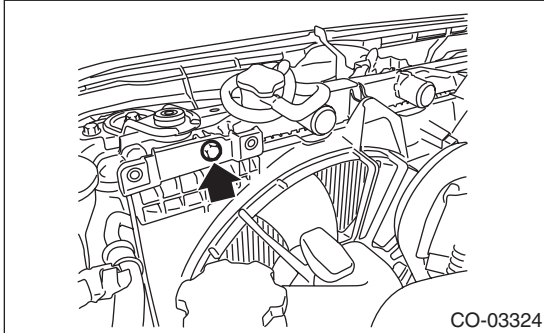

2) Install radiator inlet hoses LH and RH to the radiator.

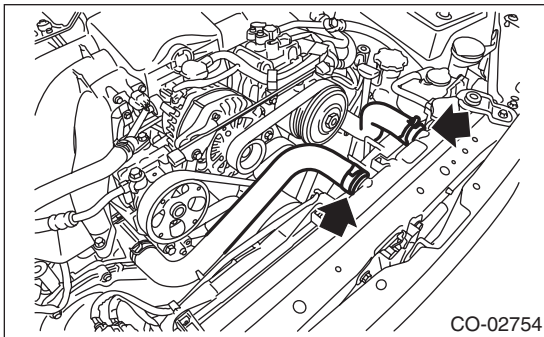

3) Install the reservoir tank. <Ref. to CO(H6DO)-25, INSTALLATION, Reservoir Tank.>

4) Attach the grille bracket.

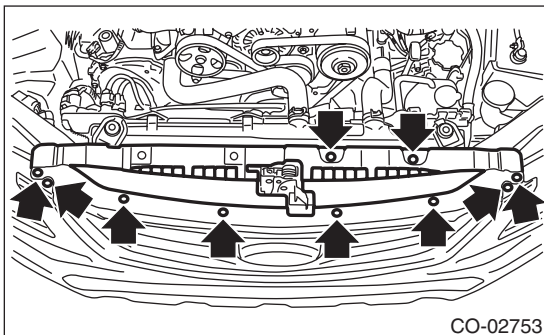

5) Install the air intake duct. <Ref. to IN(H6DO)-8, INSTALLATION, Air Intake Duct.>

6) Lift up the vehicle.

7) Connect the integrated connector of radiator main fan & fan motor and radiator sub fan & fan motor.

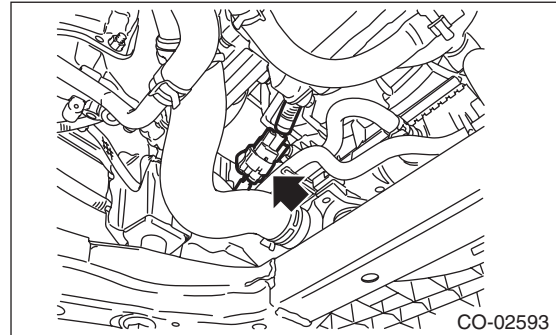

8) Install the under cover. <Ref. to EI-33, INSTALLATION, Front Under Cover.>

9) Lower the vehicle.

10) Fill engine coolant. <Ref. to CO(H6DO)-12, FILLING OF ENGINE COOLANT, REPLACEMENT, Engine Coolant.>

11) Connect the battery ground terminal.

12) Install the collector cover.

### C: DISASSEMBLY

1) Disconnect the connector from the radiator fan control unit, and remove the harness.

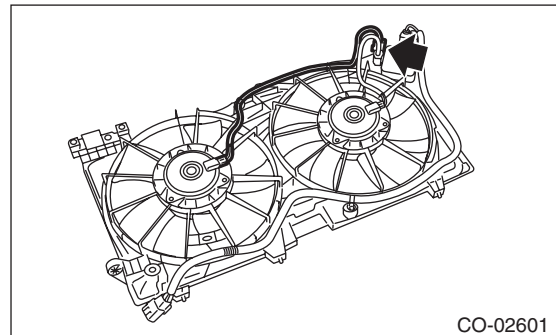

2) Remove the radiator main fan.

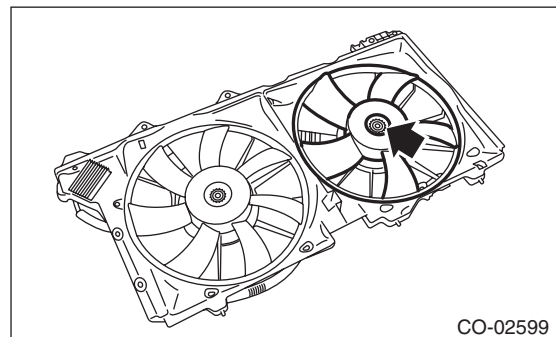

3) Remove the radiator main fan motor.

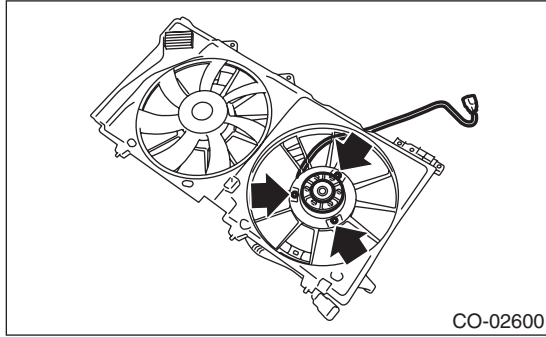

## D: ASSEMBLY

Assemble in the reverse order of disassembly.

**Tightening torque:**

**3.8 N·m (0.4 kgf-m, 2.8 ft-lb)**

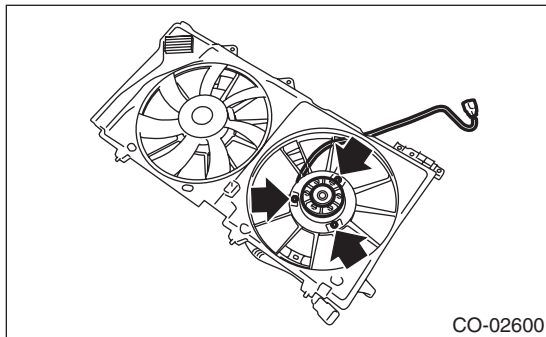

**Tightening torque:**

**6.3 N·m (0.6 kgf-m, 4.6 ft-lb)**

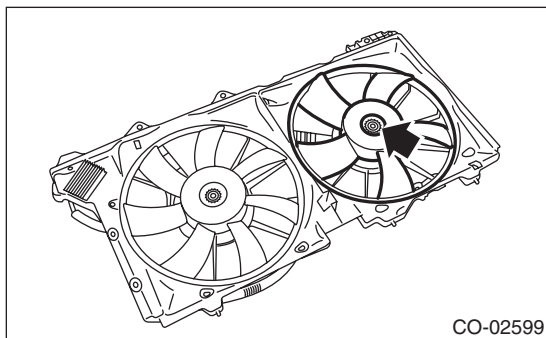

## E: INSPECTION

Check that the radiator main fan, radiator main fan shroud and main fan motor do not have deformation, cracks or damage.