

Canister

EMISSION CONTROL (AUX. EMISSION CONTROL DEVICES)

5. Canister

A: REMOVAL

- 1) Disconnect the ground cable from battery.
- 2) Remove the rear wheel LH.
- 3) Lift up the vehicle.
- 4) Remove the rear mud guard LH. <Ref. to EI-36, REMOVAL, Mud Guard.>
- 5) Disconnect the quick connectors of the vent tube (A), canister drain tube (B) and charge tube (C), and remove the tubes from tube clamp (D).

NOTE:

Disconnect the quick connector as shown in the figure.

- 6) Disconnect the connector (A) from the canister and remove the canister from the vehicle.

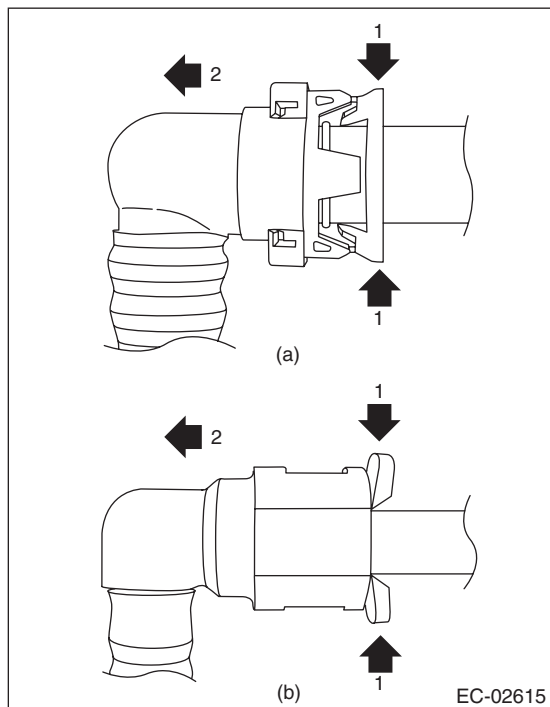

- (a) Vent tube (A) and canister drain tube (B)
- (b) Charge tube (C)

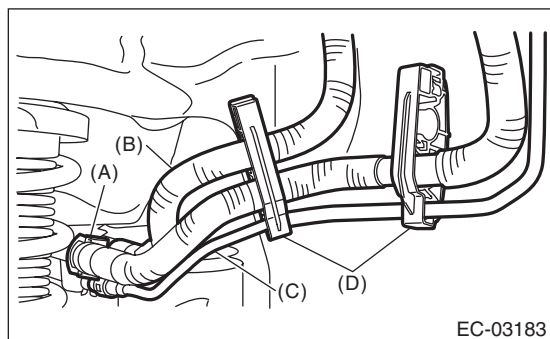
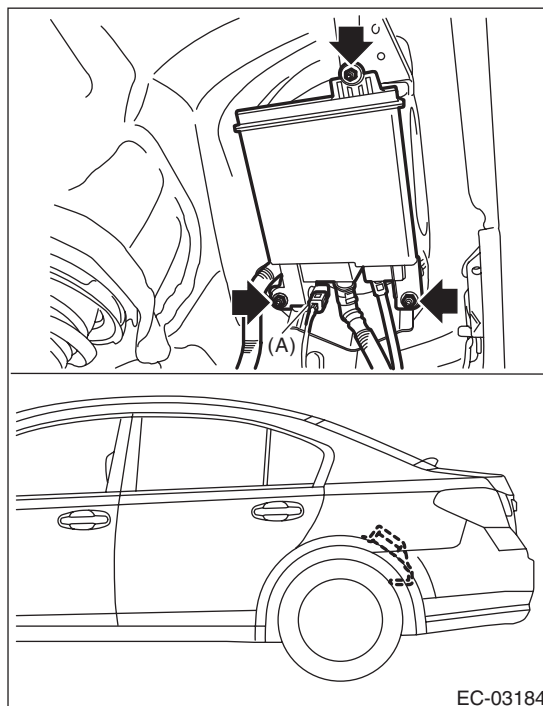

Canister

EMISSION CONTROL (AUX. EMISSION CONTROL DEVICES)

7) Disconnect the vent tube (A), canister drain tube (B) and charge tube (C) from the canister.

NOTE:

Disconnect the quick connector as shown in the figure.

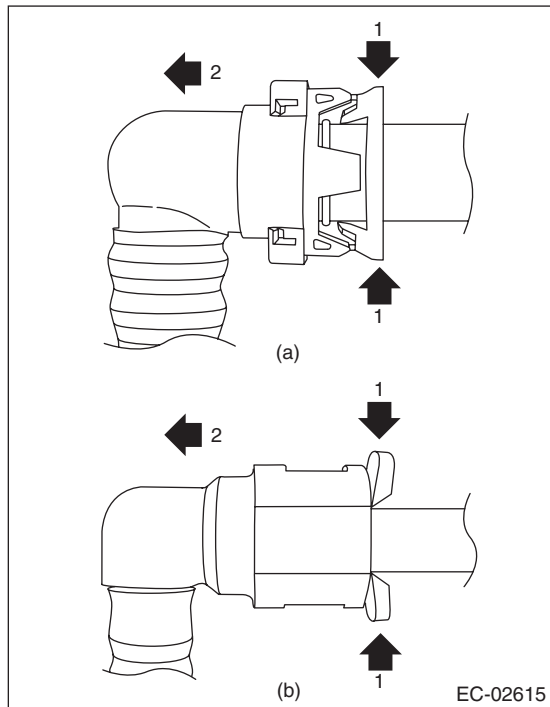

- (a) Vent tube (A) and canister drain tube (B)
- (b) Charge tube (C)

8) Disconnect the connector (A) from the leak check valve assembly, and remove the connector assembly from the canister clip.

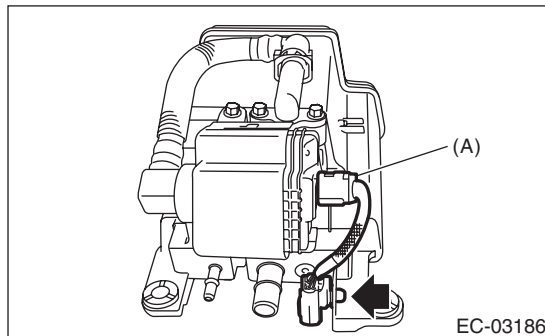

B: INSTALLATION

1) Connect the connector (A) to the leak check valve assembly, and install the connector assembly to the canister clip.

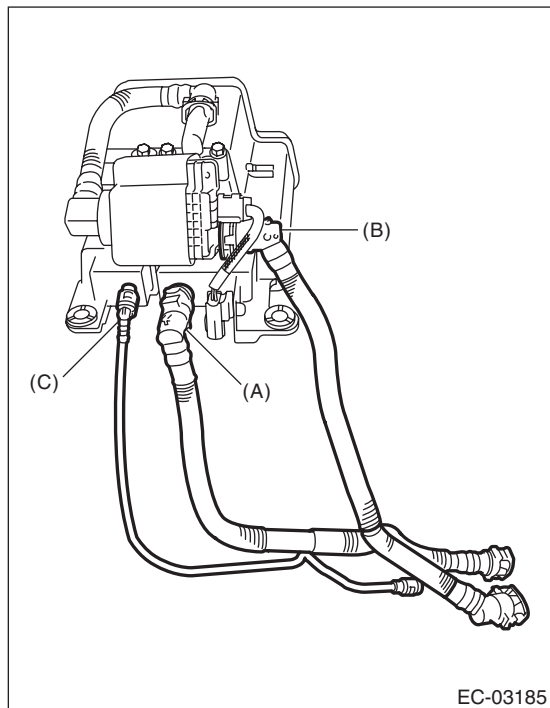
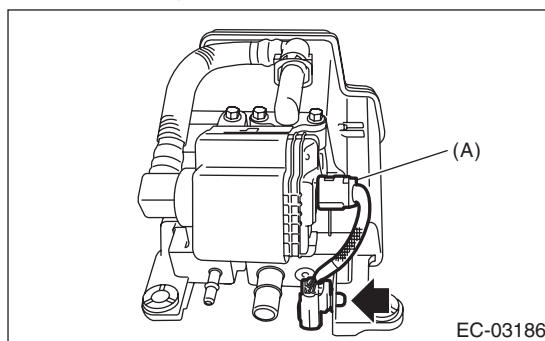

Canister

EMISSION CONTROL (AUX. EMISSION CONTROL DEVICES)

2) Connect the vent tube (A), canister drain tube (B) and charge tube (C) to the canister.

CAUTION:

- Make sure there are no damage or dust on connections. If necessary, clean the seal surface of the pipe.
- Make sure that the quick connector is securely connected.

NOTE:

Connect the quick connector as shown in the figure.

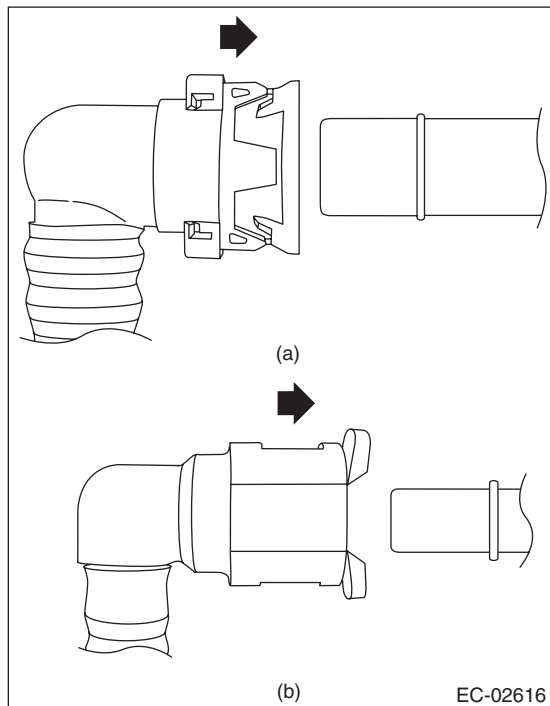

- (a) Vent tube (A) and canister drain tube (B)
(b) Charge tube (C)

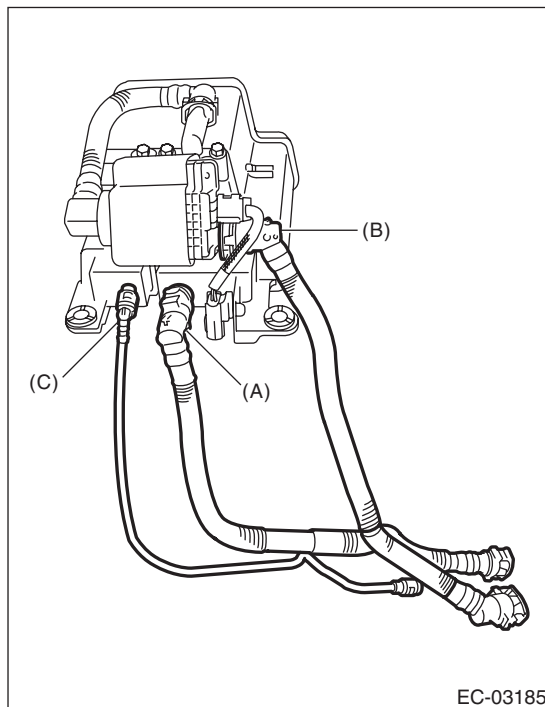

3) Install the canister to the vehicle, and connect the connector (A) to the canister.

Tightening torque:

8 N·m (0.8 kgf·m, 5.9 ft·lb)

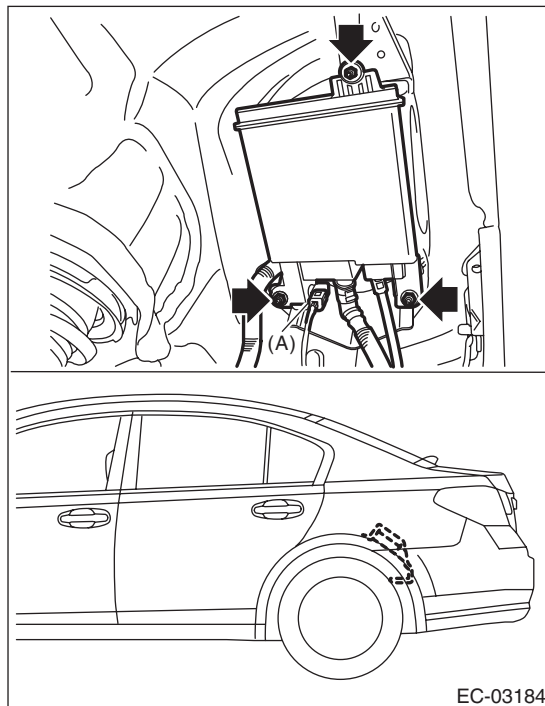

Canister

EMISSION CONTROL (AUX. EMISSION CONTROL DEVICES)

4) Attach all tubes to tube clamp (D), and connect the quick connectors of the vent tube (A), canister drain tube (B) and charge tube (C).

CAUTION:

- Make sure there are no damage or dust on connections. If necessary, clean the seal surface of the pipe.
- Make sure that the quick connector is securely connected.

NOTE:

Connect the quick connector as shown in the figure.

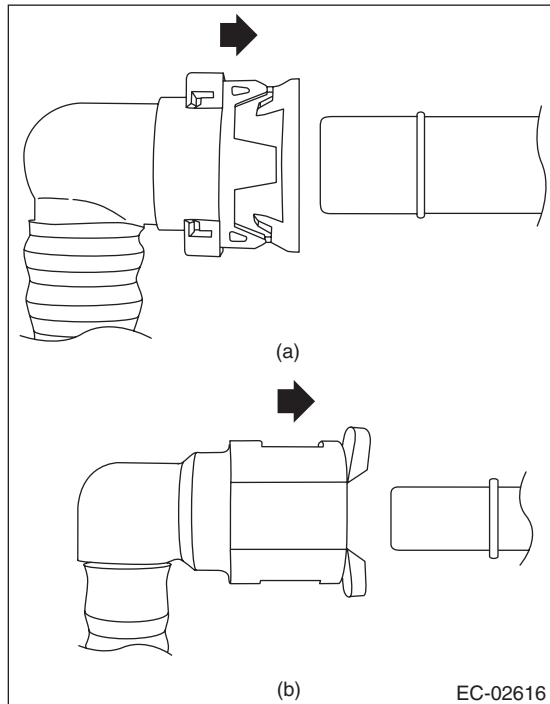

(a) Vent tube (A) and canister drain tube (B)

(b) Charge tube (C)

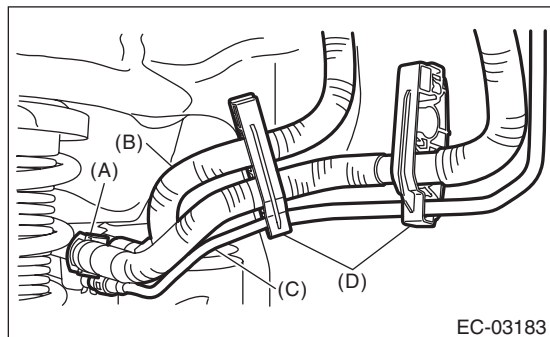

5) Install the rear mud guard LH. <Ref. to EI-36, INSTALLATION, Mud Guard.>

6) Lower the vehicle.

7) Install the rear wheel LH.

Tightening torque:

120 N·m (12.2 kgf·m, 88.5 ft·lb)

8) Connect the battery ground terminal.

C: INSPECTION

- 1) Check that the canister has no deformation, cracks or other damages.
- 2) Check that the tube has no cracks, damage or loose part.