

10. Mass Air Flow and Intake Air Temperature Sensor

A: REMOVAL

- 1) Disconnect the ground cable from battery.
- 2) Disconnect the connector (A) from air flow and intake air temperature sensor.

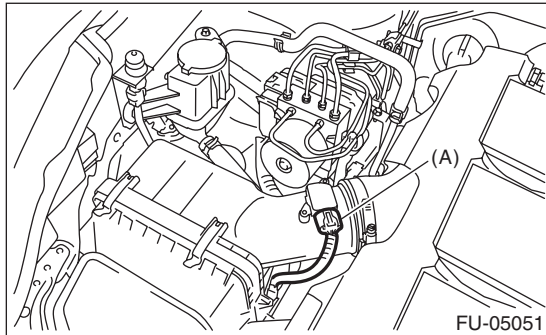

- 3) Remove the mass air flow and intake air temperature sensor.

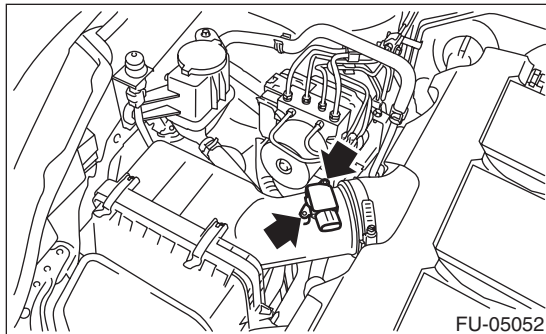

B: INSTALLATION

Install in the reverse order of removal.

Tightening torque:

1 N·m (0.1 kgf·m, 0.7 ft·lb)

C: INSPECTION

1. CHECK MASS AIR FLOW SENSOR UNIT

- 1) Connect battery positive terminal to terminal No. 3 and battery ground terminal to terminal No. 4, circuit tester positive terminal to terminal No. 5 and the circuit tester negative terminal to terminal No. 4.

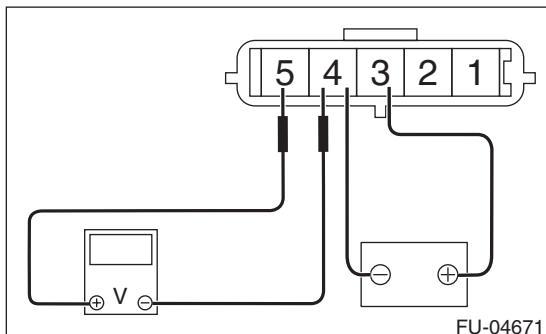

- 2) Check that the voltage changes when air is blown to the mass air flow sensor unit from arrow direction.

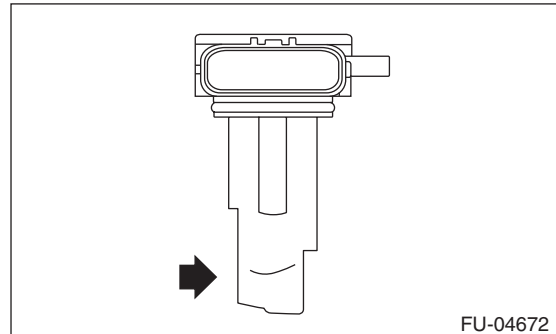

2. CHECK INTAKE AIR TEMPERATURE SENSOR UNIT

Measure the resistance between intake air temperature sensor terminals.

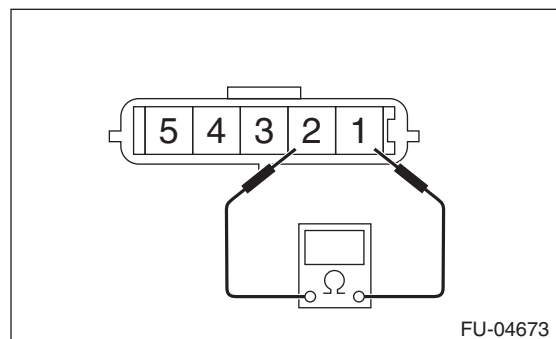

Temperature	Terminal No.	Standard
-20°C (-4°F)	1 and 2	16.0±2.4 kΩ
20°C (68°F)		2.45±0.24 kΩ
60°C (140°F)		0.58±0.087 kΩ

3. OTHER INSPECTIONS

- 1) Check that the mass air flow and intake air temperature sensor has no deformation, cracks or other damages.
- 2) Check that the mass air flow and intake air temperature sensor has no dirt.