

5. Crankshaft Position Sensor

A: REMOVAL

1) Remove the collector cover.

NOTE:

Follow the steps below when removing the collector cover.

(1) Pull up the two points at the rear (A).

(2) Pull up the two points at the front (B) while moving them forward.

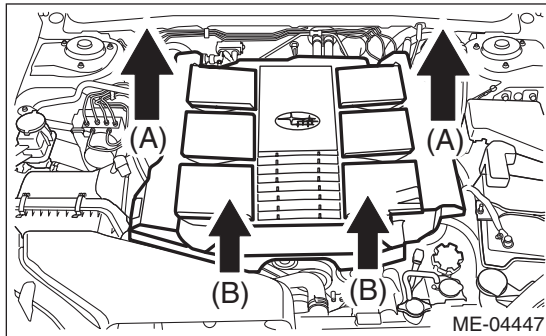

2) Disconnect the ground cable from battery.

3) Loosen the clamp (A) which connects the air intake boot assembly.

4) Loosen the bolt (B) which secures the air intake boot assembly to the collector cover bracket.

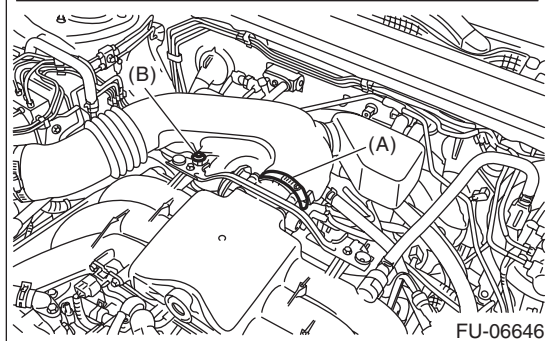
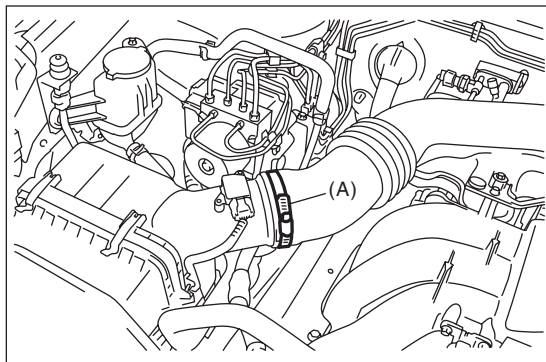

5) Remove the air intake boot assembly, and move it to the left side wheel apron.

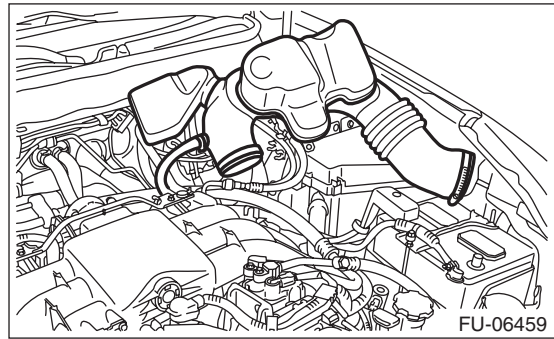

6) Remove the throttle body from the intake manifold.

NOTE:

Do not disconnect the inlet and outlet hoses of engine coolant.

7) Remove the service hole plug.

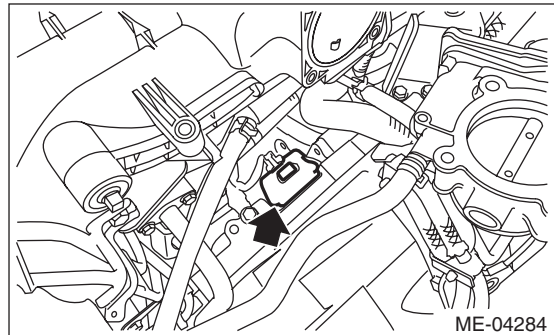

8) Remove the crankshaft position sensor.

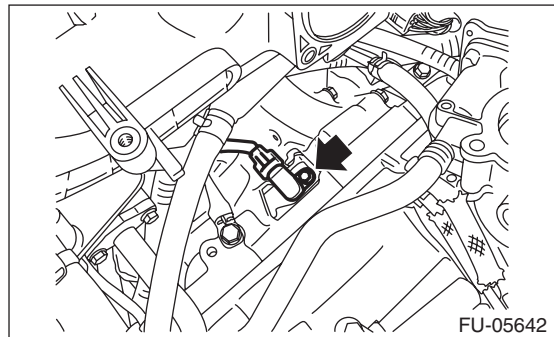

9) Disconnect the connector from the crankshaft position sensor.

Crankshaft Position Sensor

FUEL INJECTION (FUEL SYSTEMS)

B: INSTALLATION

Install in the reverse order of removal.

Tightening torque:

6.4 N·m (0.7 kgf·m, 4.7 ft·lb)

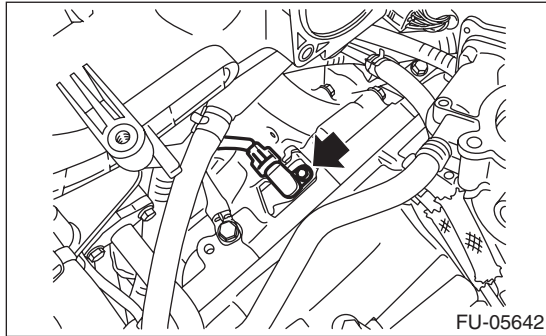

Tightening torque:

Clamp (A)

3 N·m (0.3 kgf·m, 2.2 ft·lb)

Bolt (B)

6.5 N·m (0.7 kgf·m, 4.8 ft·lb)

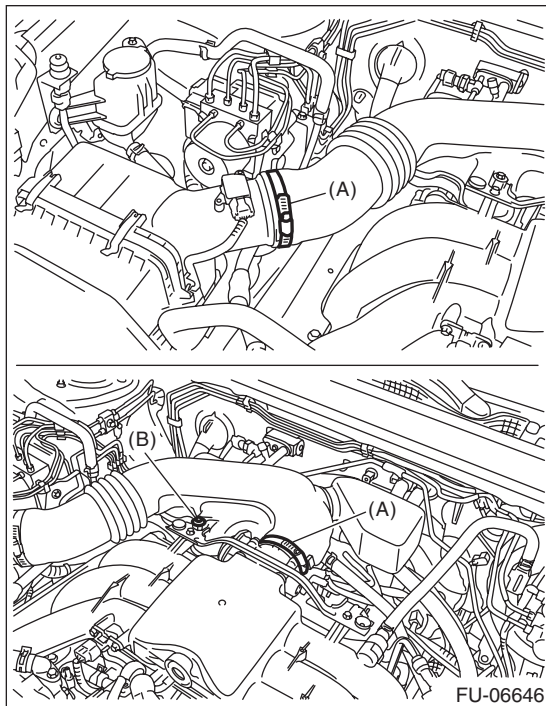

C: INSPECTION

1. CRANKSHAFT POSITION SENSOR (METHOD WITH CIRCUIT TESTER)

Measure the resistance between crankshaft position sensor terminals.

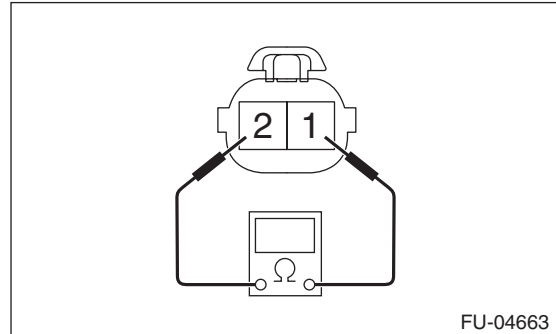

Terminal No.	Standard
1 and 2	1.86±0.186 kΩ

2. CRANKSHAFT POSITION SENSOR (METHOD WITH OSCILLOSCOPE)

- 1) Prepare an oscilloscope.
- 2) Remove the glove box lid assembly. <Ref. to EI-65, REMOVAL, Glove Box.>
- 3) Connect the probe to ECM connector.

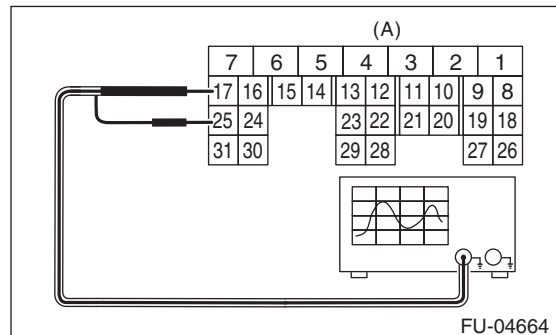

(A) To ECM connector

Terminal No.	Probe
17	+
25	-

- 4) Start the engine and let it idle.

5) Check that the pattern is the same as the waveform and voltage shown below.

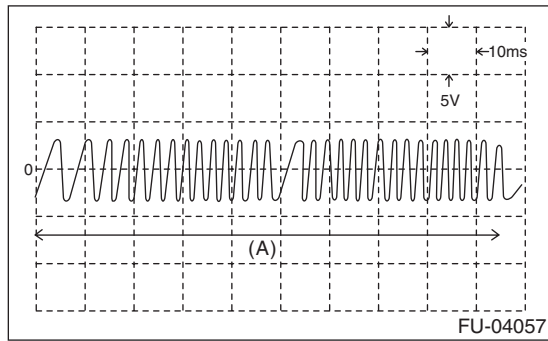

(A) One crankshaft rotation

6) After inspection, install the related parts in the reverse order of removal.

3. OTHER INSPECTIONS

Check that the crankshaft position sensor has no deformation, cracks or other damages.