

4. Air Intake Boot

A: REMOVAL

1) Remove the collector cover.

NOTE:

Follow the steps below when removing the collector cover.

- (1) Pull up the two points at the rear (A).
- (2) Pull up the two points at the front (B) while moving them forward.

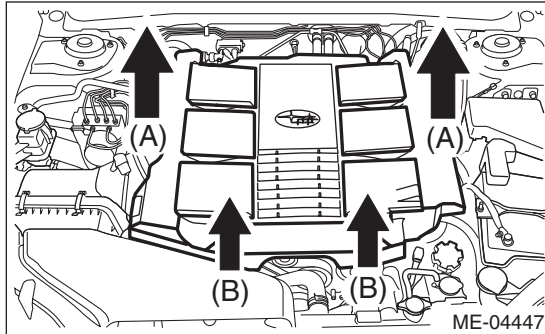

2) Loosen the clamp which connects the air intake boot assembly and air cleaner case (rear).

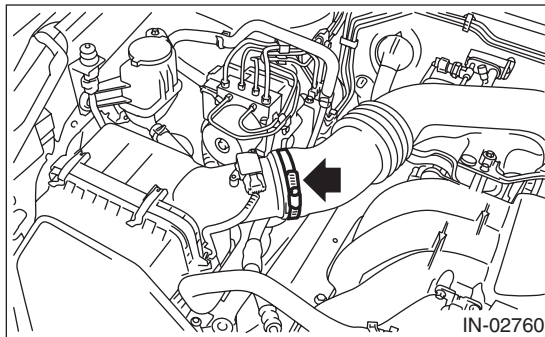

3) Loosen the clamp (A) which connects the air intake boot assembly and throttle body.

4) Loosen the bolt (B) which secures the air intake boot assembly and collector cover bracket.

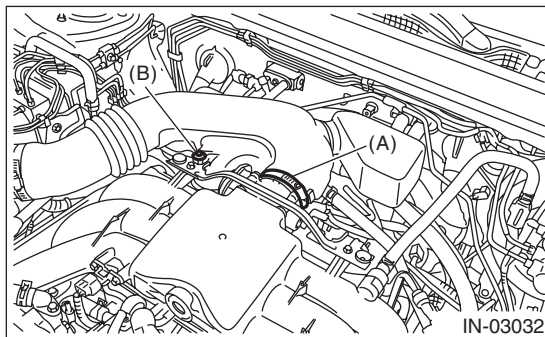

5) Disconnect the blow-by hose and remove the air intake boot assembly.

B: INSTALLATION

- 1) Install the air intake boot assembly and connect the blow-by hose.
- 2) Tighten the clamp (A) which connects the air intake boot assembly and throttle body.
- 3) Tighten the bolt (B) which secures the air intake boot assembly and collector cover bracket.

Tightening torque:

Clamp (A)

3 N·m (0.3 kgf-m, 2.2 ft-lb)

Bolt (B)

6.5 N·m (0.7 kgf-m, 4.8 ft-lb)

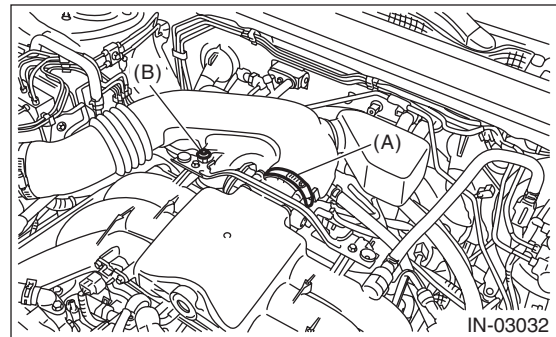

4) Tighten the clamp which connects the air intake boot assembly and air cleaner case (rear).

Tightening torque:

3 N·m (0.3 kgf-m, 2.2 ft-lb)

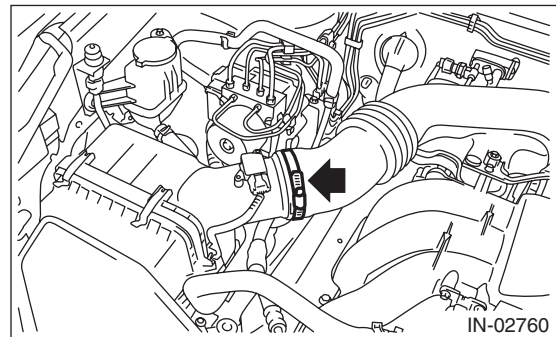

5) Install the collector cover.

C: INSPECTION

- 1) Check that the air intake boot assembly does not have deformation, cracks or other damages.
- 2) Check there is no foreign matter in the air intake boot assembly.