

Oil Level Switch

LUBRICATION

9. Oil Level Switch

A: REMOVAL

- 1) Disconnect the ground cable from battery.
- 2) Lift up the vehicle.
- 3) Remove the under cover. <Ref. to EI-33, REMOVAL, Front Under Cover.>
- 4) Drain the engine oil. <Ref. to LU(H6DO)-10, REPLACEMENT, Engine Oil.>
- 5) Disconnect the connector of oil level switch from the engine harness.

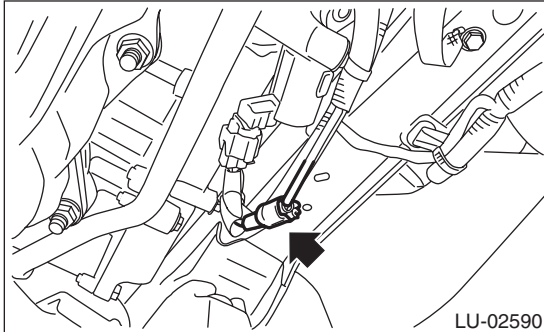

- 6) Remove the clips which hold the front camshaft cap (LH) and cylinder head (LH).

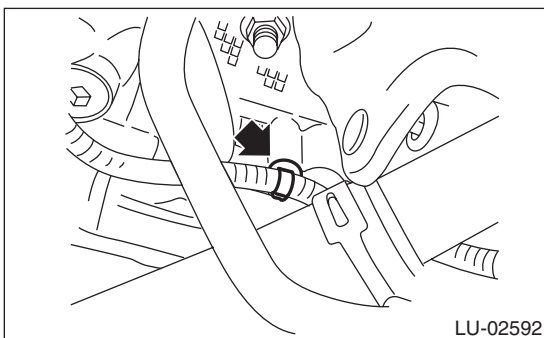
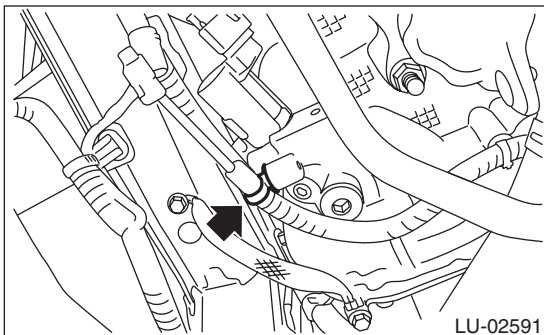

- 7) Remove the oil level switch from the oil pan upper.

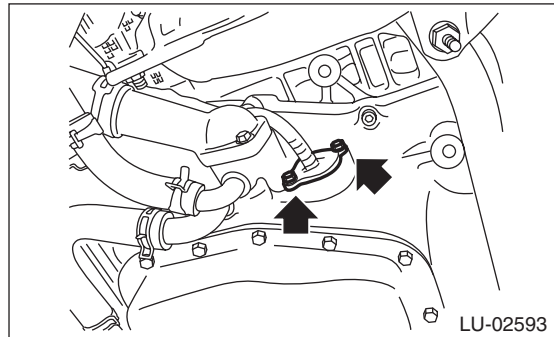

- 8) Remove the oil level switch.

B: INSTALLATION

- 1) Route the oil level switch harness as shown in the figure.

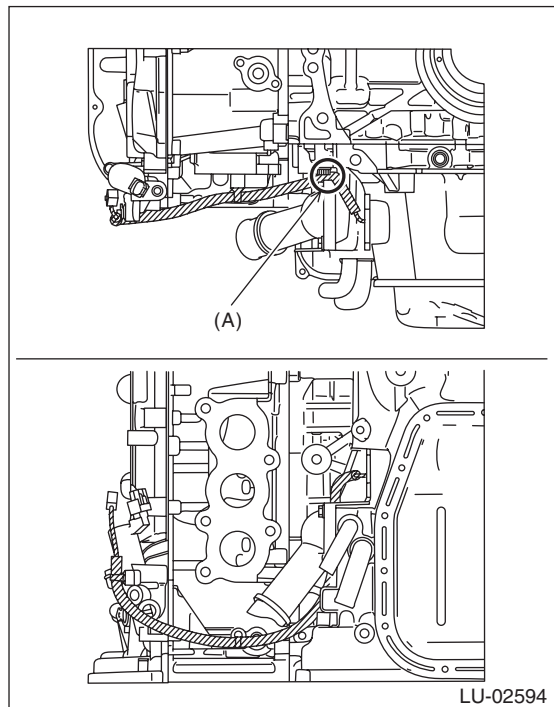

- (A) Route the oil level switch harness through inside of oil pan upper bolt.

2) Attach the oil level switch to the oil pan upper.

NOTE:

- Use new O-rings.
- Apply engine oil to O-ring.

Tightening torque:

6.4 N·m (0.7 kgf·m, 4.7 ft·lb)

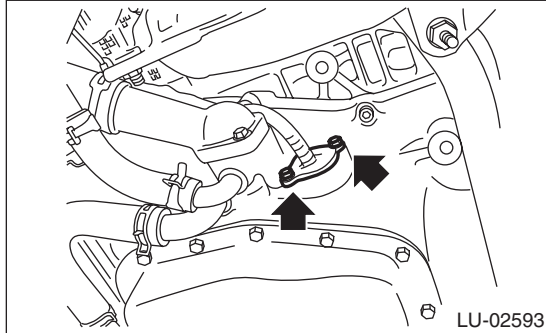

3) Attach the clips which hold the front camshaft cap (LH) and cylinder head (LH).

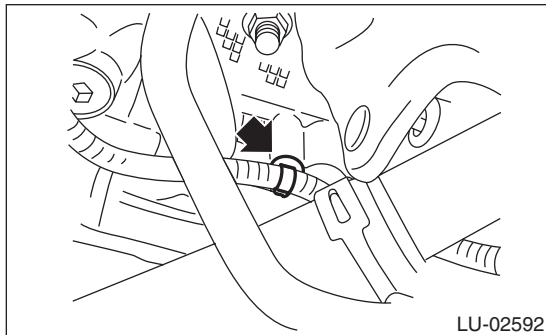
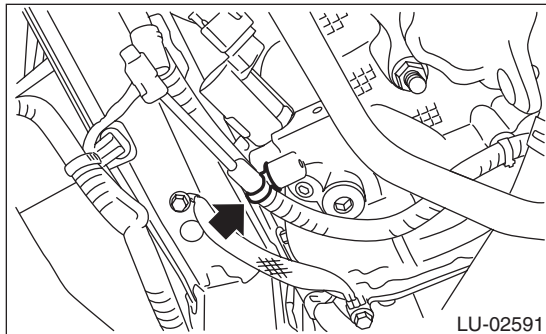

4) Connect the connector of the oil level switch to the engine harness.

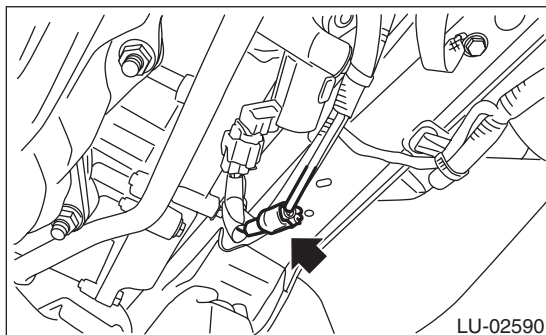

5) Install the under cover. <Ref. to EI-33, INSTALLATION, Front Under Cover.>

6) Lower the vehicle.

7) Refill the engine oil. <Ref. to LU(H6DO)-10, REPLACEMENT, Engine Oil.>

8) Check the engine oil level. <Ref. to LU(H6DO)-10, INSPECTION, Engine Oil.>

Oil Level Switch

LUBRICATION

C: WIRING DIAGRAM

- Engine electrical system <Ref. to WI-122, WIRING DIAGRAM, Engine Electrical System.>
- CAN communication system <Ref. to WI-83, WIRING DIAGRAM, CAN Communication System.>

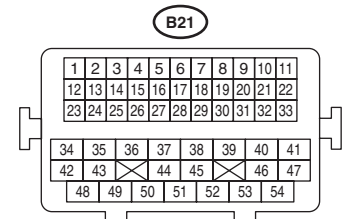
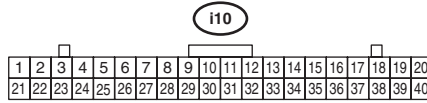
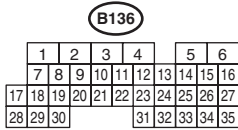
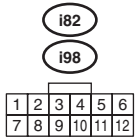
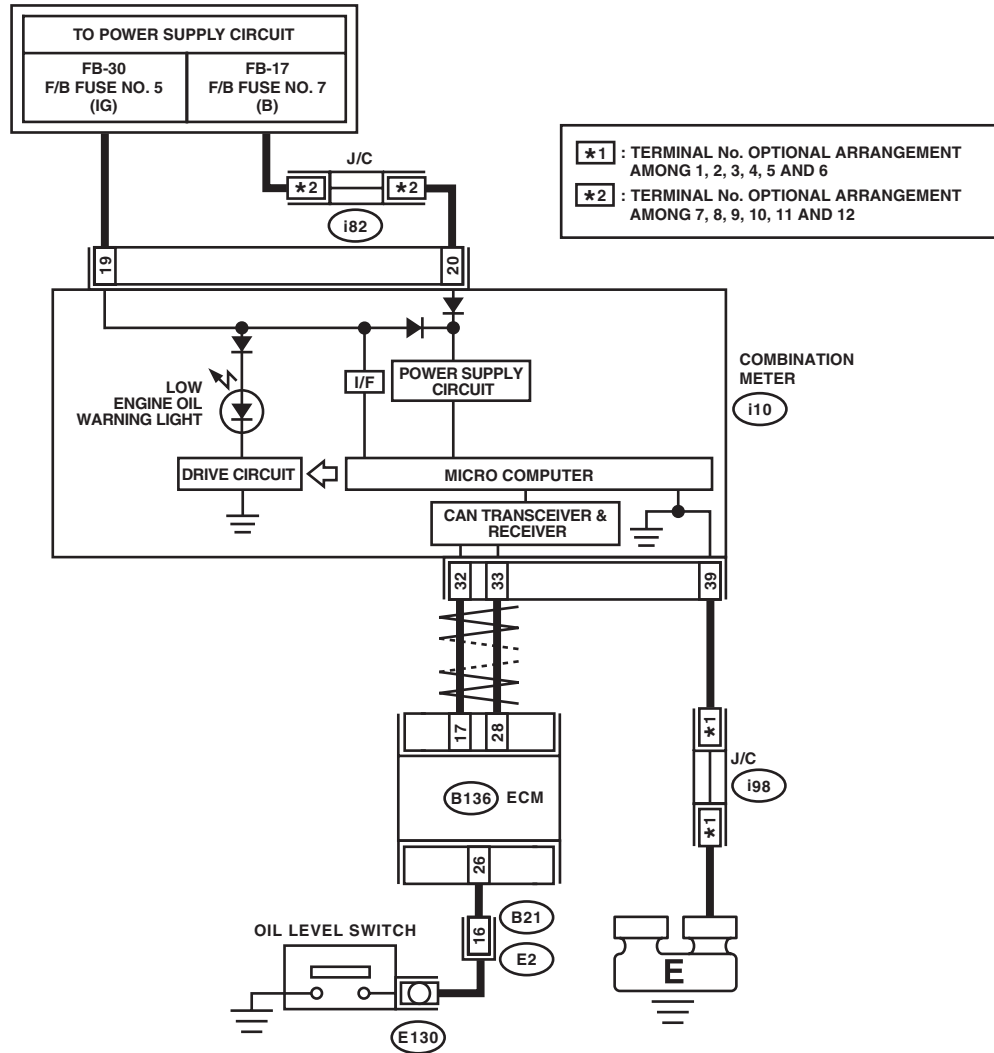

LU-02654

D: INSPECTION

1. INSPECTION WHEN LOW ENGINE OIL WARNING LIGHT IS ILLUMINATED

Step	Check	Yes	No
1	CHECK ENGINE OIL LEVEL.	Is engine oil level normal?	<p>Go to step 2.</p> <p>Replace engine oil or refill, and check again while the oil level is normal condition. <Ref. to LU(H6DO)-10, REPLACEMENT, Engine Oil.></p> <p>To turn off the low engine oil warning light, install the spare fuse at the delivery (test) mode fuse in the main fuse box.</p> <p>Then turn the ignition switch to ON (engine off) again, to confirm the low engine oil warning light turns off.</p> <p>Remove the spare fuse installed to finish.</p> <p>NOTE: The engine oil level switch is normal if the low engine oil warning light turns off with the delivery (test) mode fuse inserted.</p>
2	CHECK LAN SYSTEM.	Has a DTC of the LAN system been input?	<p>Perform the diagnosis according to DTC.</p> <p>Go to step 3.</p>

Oil Level Switch

LUBRICATION

Step	Check	Yes	No
3 CHECK OIL LEVEL SWITCH CIRCUIT. 1) Turn the ignition switch to ON (engine OFF). 2) Read the current data for engine in the Subaru Select Monitor to confirm the item for "Oil level switch". <Ref. to EN(H6DO)(diag)-40, READ CURRENT DATA FOR ENGINE (NORMAL MODE), OPERATION, Subaru Select Monitor.>	Is the "Oil level switch" signal displayed in Subaru Select Monitor HIGH?	To turn off the low engine oil warning light, install the spare fuse at the delivery (test) mode fuse in the main fuse box. Then turn the ignition switch to ON (engine off) again, to confirm the low engine oil warning light turns off. Remove the spare fuse installed to finish. NOTE: The engine oil level switch is normal if the low engine oil warning light turns off with the delivery (test) mode fuse inserted.	Go to step 4.
4 CHECK COMBINATION METER. Perform the self-diagnosis of combination meter to check if there are any faults in the combination meter. <Ref. to IDI-8, OPERATION, Combination Meter System.>	Is combination meter OK?	Go to step 5.	Replace the combination meter. <Ref. to IDI-25, REMOVAL, Combination Meter.>
5 CHECK SECURE CONNECTION OF CONNECTOR BETWEEN ENGINE HARNESS AND OIL LEVEL SWITCH.	Is there any insecure connection?	Remedy the connection condition. Then, to turn off the low engine oil warning light, install the spare fuse at the delivery (test) mode fuse in the main fuse box. Then turn the ignition switch to ON (engine off) again, to confirm the low engine oil warning light turns off. Remove the spare fuse installed to finish. NOTE: The engine oil level switch is normal if the low engine oil warning light turns off with the delivery (test) mode fuse inserted.	Go to step 6.

Oil Level Switch

LUBRICATION

Step	Check	Yes	No
<p>6</p> <p>CHECK OIL LEVEL SWITCH.</p> <p>1) Deliberately short circuits by connecting the engine harness connector terminal and chassis ground.</p> <p>2) Turn the ignition switch to ON (engine OFF).</p> <p>3) Read the current data for engine in the Subaru Select Monitor to confirm the item for "Oil level switch". <Ref. to EN(H6DO)(diag)-40, READ CURRENT DATA FOR ENGINE (NORMAL MODE), OPERATION, Subaru Select Monitor.></p> <p>Connector & terminal (E130) No. 1 — Chassis ground:</p>	<p>Is the "Oil level switch" signal displayed in Subaru Select Monitor HIGH?</p>	<p>Replace the oil level switch. <Ref. to LU(H6DO)-18, REMOVAL, Oil Level Switch.></p>	<p>Go to step 7.</p>
<p>7</p> <p>CHECK SECURE CONNECTION OF CONNECTOR BETWEEN BULKHEAD HARNESS AND ENGINE HARNESS.</p>	<p>Is there any insecure connection?</p>	<p>Remedy the connection condition. Then, to turn off the low engine oil warning light, install the spare fuse at the delivery (test) mode fuse in the main fuse box. Then turn the ignition switch to ON (engine off) again, to confirm the low engine oil warning light turns off. Remove the spare fuse installed to finish.</p> <p>NOTE: The engine oil level switch is normal if the low engine oil warning light turns off with the delivery (test) mode fuse inserted.</p>	<p>Go to step 8.</p>
<p>8</p> <p>CHECK ENGINE HARNESS.</p> <p>1) Disconnect the connector on the oil level switch side for the engine harness.</p> <p>2) Disconnect the connector on the bulkhead harness side for the engine harness.</p> <p>3) Measure the resistance between connector terminals.</p> <p>Connector & terminal (E2) No. 16 — (E130) No. 1:</p>	<p>Is the resistance less than 1 Ω?</p>	<p>Go to step 9.</p>	<p>Repair or replace the open circuit of engine harness.</p>

Oil Level Switch

LUBRICATION

Step	Check	Yes	No
<p>9</p> <p>CHECK SECURE CONNECTION OF CONNECTOR BETWEEN ENGINE CONTROL MODULE (ECM) AND BULKHEAD HARNESS.</p> <p>Remove the glove box lid assembly. <Ref. to EI-65, REMOVAL, Glove Box.></p>	<p>Is there any insecure connection?</p>	<p>Remedy the connection condition. Then, to turn off the low engine oil warning light, install the spare fuse at the delivery (test) mode fuse in the main fuse box. Then turn the ignition switch to ON (engine off) again, to confirm the low engine oil warning light turns off. Remove the spare fuse installed to finish.</p> <p>NOTE: The engine oil level switch is normal if the low engine oil warning light turns off with the delivery (test) mode fuse inserted.</p>	<p>Go to step 10.</p>
<p>10</p> <p>CHECK BULKHEAD HARNESS.</p> <p>1) Remove the glove box lid assembly. <Ref. to EI-65, REMOVAL, Glove Box.></p> <p>2) Disconnect the engine control module (ECM) side connector for the bulkhead harness.</p> <p>3) Disconnect the engine harness connectors from the bulkhead harness.</p> <p>4) Measure the resistance between connector terminals.</p> <p>Connector & terminal (B136) No. 26 — (B21) No. 16:</p>	<p>Is the resistance less than 1 Ω?</p>	<p>Replace the engine control module (ECM). <Ref. to FU(H6DO)-54, REMOVAL, Engine Control Module (ECM).></p>	<p>Repair or replace the open circuit of the bulkhead harness.</p>

2. OTHER INSPECTIONS

- 1) Check that the oil level switch does not have deformation, cracks, or damage.
- 2) Check the oil level switch installation part for oil leakage and oil seepage.