

10. Engine Mounting

A: REMOVAL

1) Change the front hood damper bolt mounting position from (A) to (B), and completely open the front hood.

Tightening torque:

20 N·m (2.0 kgf·m, 14.8 ft-lb)

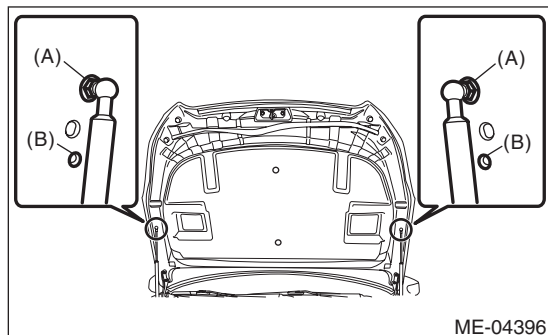

2) Remove the collector cover.

NOTE:

Follow the steps below when removing the collector cover.

- (1) Pull up the two points at the rear (A).
- (2) Pull up the two points at the front (B) while moving them forward.

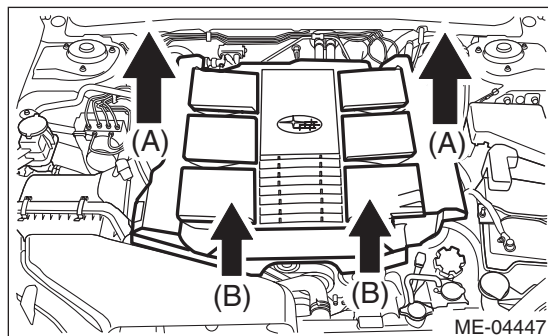

3) Loosen the clamp (A) which connects the air intake boot assembly.

4) Loosen the bolt (B) which secures the air intake boot assembly to the collector cover bracket.

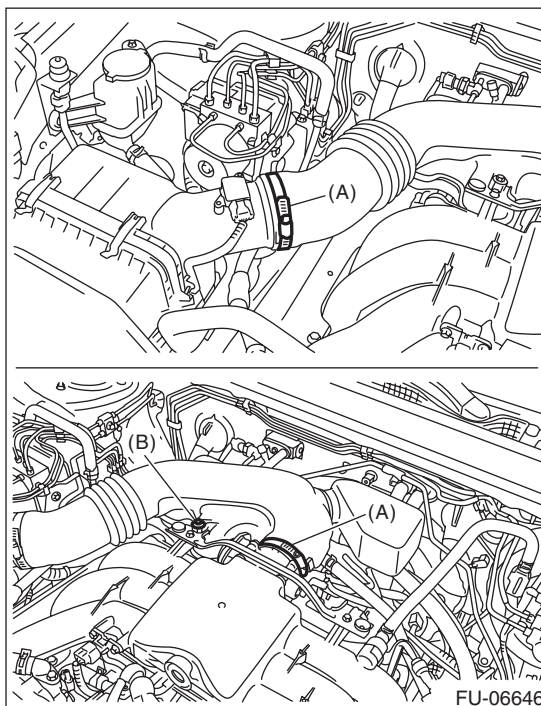

5) Remove the air intake boot assembly, and move it to the left side wheel apron.

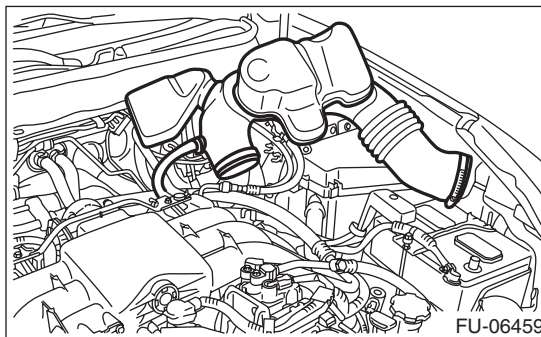

6) Remove the air intake duct and air cleaner case.
<Ref. to IN(H6DO)-8, REMOVAL, Air Intake Duct.>
<Ref. to IN(H6DO)-5, REMOVAL, Air Cleaner Case.>

7) Remove the grille bracket.

NOTE:

Remove ten clips when removing the grille bracket.

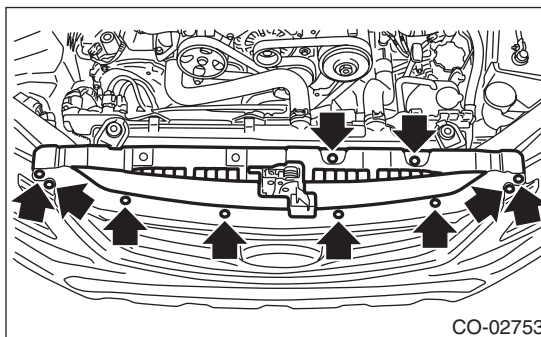

8) Lift up the vehicle.

Engine Mounting

MECHANICAL

9) Remove the under cover. <Ref. to EI-33, REMOVAL, Front Under Cover.>

10) Drain engine coolant completely. <Ref. to CO(H6DO)-12, DRAINING OF ENGINE COOLANT, REPLACEMENT, Engine Coolant.>

11) Lower the vehicle.

12) Remove the radiator main fan & fan motor and radiator sub fan & fan motor. <Ref. to CO(H6DO)-21, REMOVAL, Radiator Main Fan and Fan Motor.> <Ref. to CO(H6DO)-24, REMOVAL, Radiator Sub Fan and Fan Motor.>

13) Disconnect the engine harness.

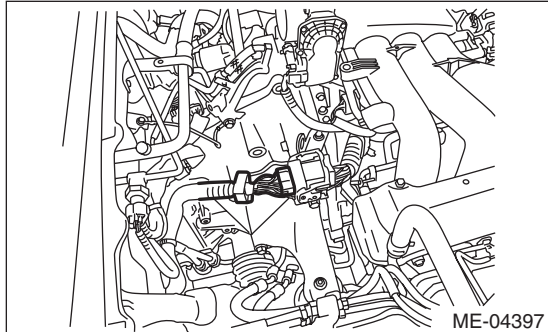

14) Disconnect the connector from the throttle body.

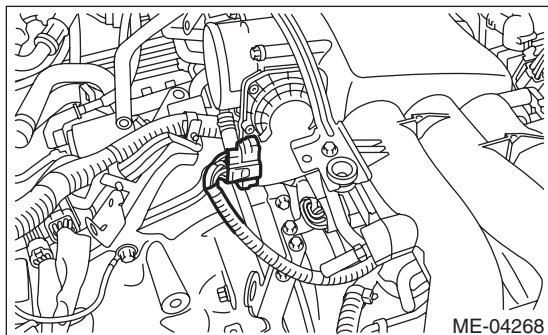

15) Remove the engine harness connector from the engine hanger bracket.

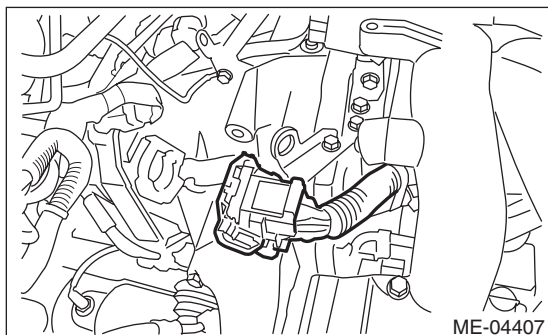

16) Remove the engine hanger bracket.

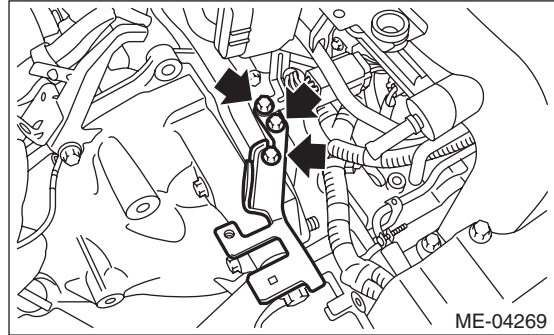

17) Remove the throttle body from the intake manifold.

NOTE:

Do not disconnect the inlet and outlet hoses of engine coolant.

18) Attach the ST.

ST 18360AA020 HANGER

Tightening torque:

19 N·m (1.9 kgf·m, 14.0 ft·lb)

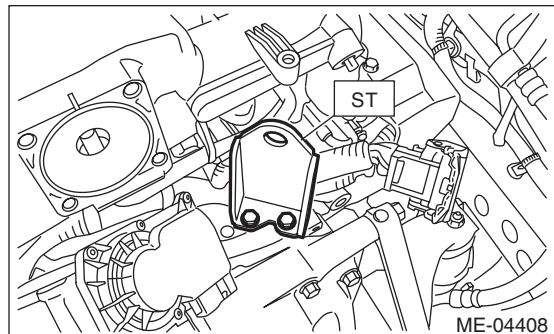

19) Support the engine with a lifting device and wire ropes.

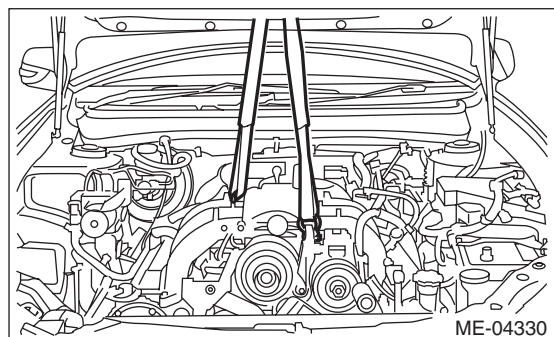

20) Remove the front mount.

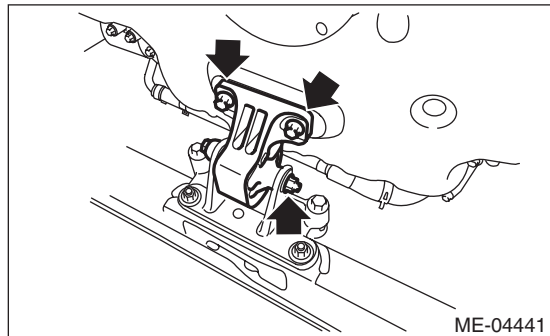

21) Remove the front mounting bracket from the cradle.

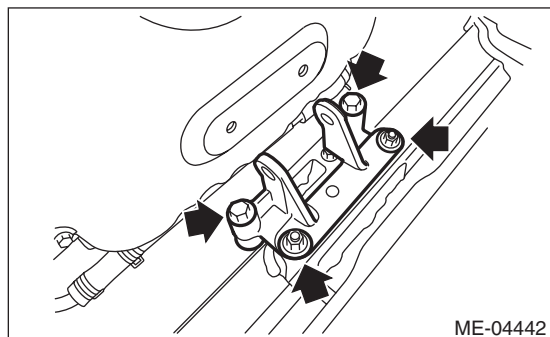

22) Remove the bracket from the cradle.

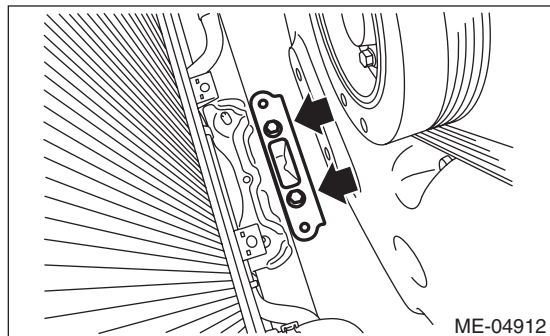

B: INSTALLATION

1) Install the bracket to the cradle.

Tightening torque:

65 N·m (6.6 kgf-m, 47.9 ft-lb)

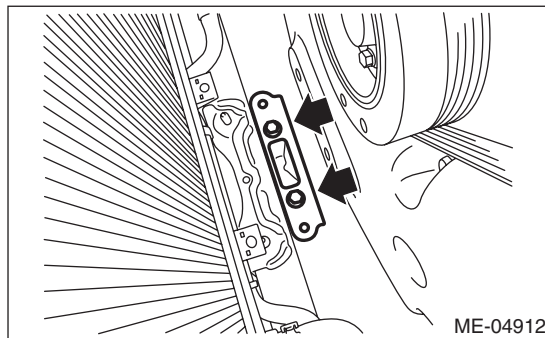

2) Install front mounting bracket to the cradle.

Tightening torque:

60 N·m (6.1 kgf-m, 44.3 ft-lb)

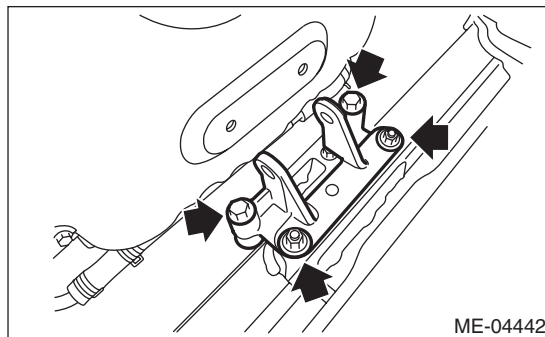

3) Install the front mount.

Tightening torque:

T1: 25 N·m (2.5 kgf-m, 18.4 ft-lb)

T2: 45 N·m (4.6 kgf-m, 33.2 ft-lb)

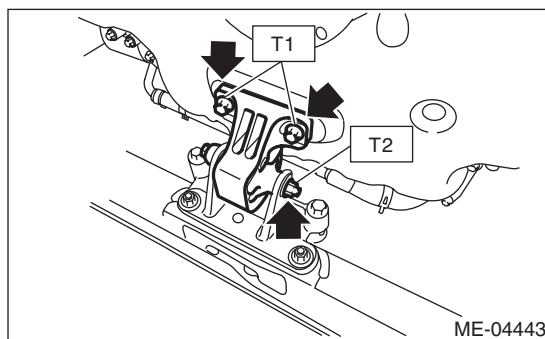

Engine Mounting

MECHANICAL

- 4) Remove the lifting device and wire ropes.

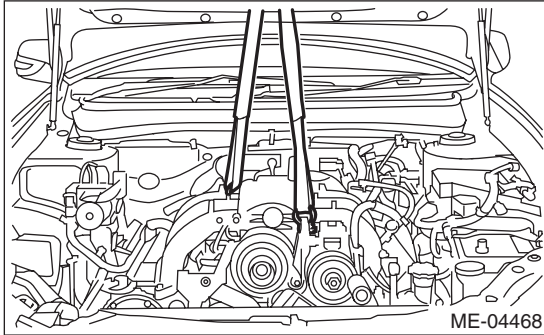

- 5) Install the radiator main fan & fan motor and radiator sub fan & fan motor. <Ref. to CO(H6DO)-22, INSTALLATION, Radiator Main Fan and Fan Motor.> <Ref. to CO(H6DO)-24, INSTALLATION, Radiator Sub Fan and Fan Motor.>

- 6) Lift up the vehicle.

- 7) Install the under cover. <Ref. to EI-33, INSTALLATION, Front Under Cover.>

- 8) Lower the vehicle.

- 9) Remove the ST.

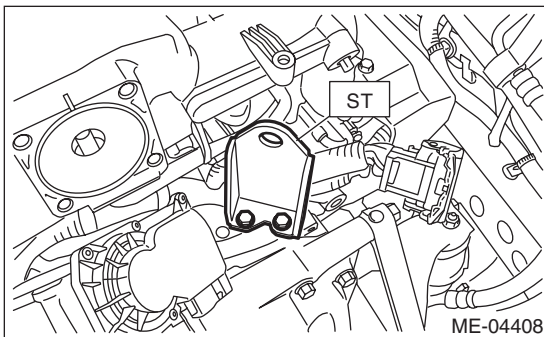

- 10) Install the throttle body to intake manifold.

NOTE:

Use a new gasket.

Tightening torque:

8 N·m (0.8 kgf-m, 5.9 ft-lb)

- 11) Install the engine hanger bracket.

Tightening torque:

19 N·m (1.9 kgf-m, 14.0 ft-lb)

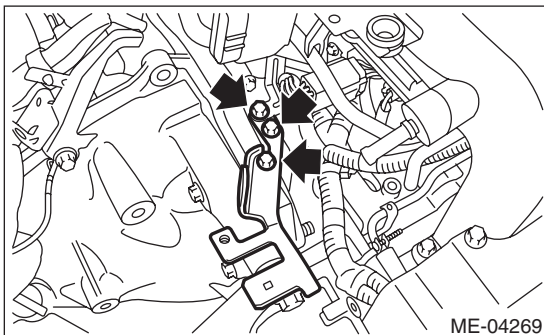

- 12) Install the engine harness connector to the engine hanger bracket.

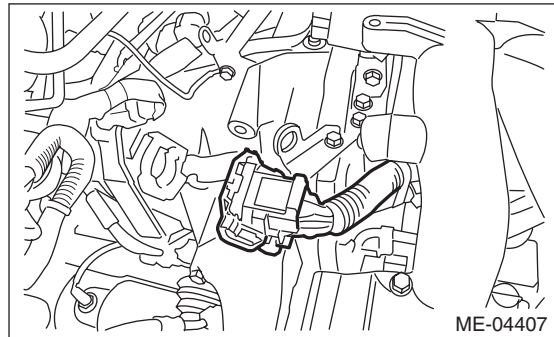

- 13) Connect the connector to the throttle body.

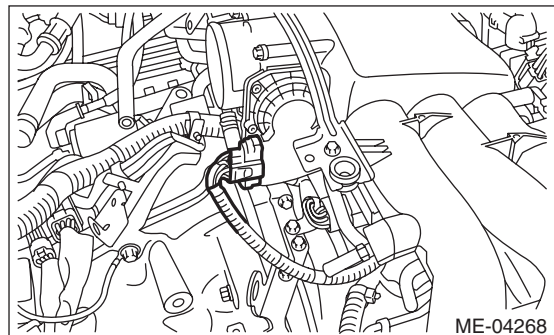

- 14) Connect the engine harness.

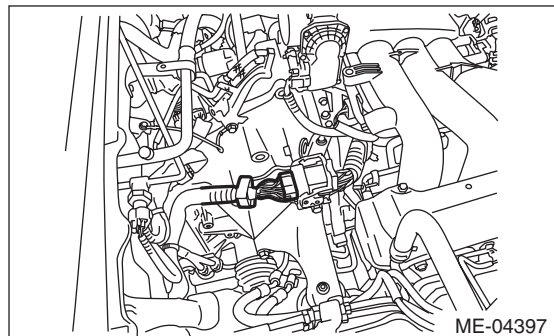

- 15) Attach the grille bracket.

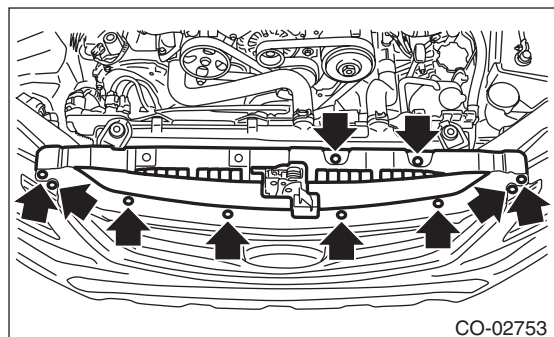

- 16) Install the air intake duct and air cleaner case. <Ref. to IN(H6DO)-8, INSTALLATION, Air Intake Duct.> <Ref. to IN(H6DO)-5, INSTALLATION, Air Cleaner Case.>

17) Install the air intake boot assembly.

Tightening torque:

Clamp (A)

3 N·m (0.3 kgf-m, 2.2 ft-lb)

Bolt (B)

6.5 N·m (0.7 kgf-m, 4.8 ft-lb)

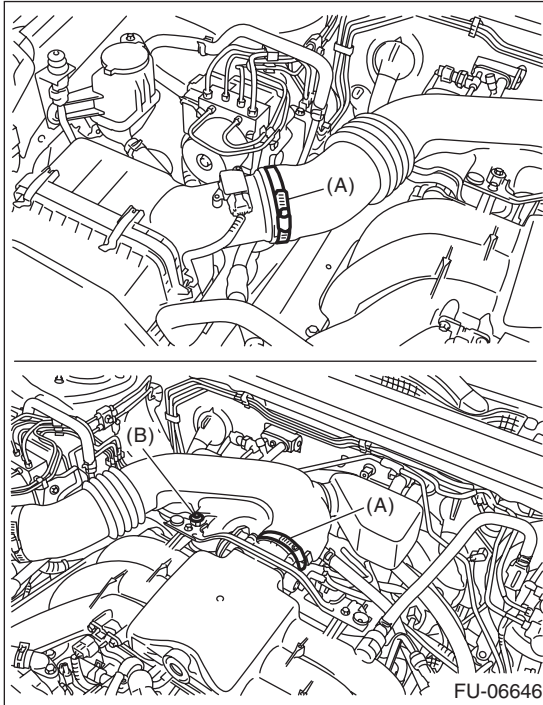

18) Connect the ground cable to battery.

19) Fill engine coolant. <Ref. to CO(H6DO)-12, FILLING OF ENGINE COOLANT, REPLACEMENT, Engine Coolant.>

20) Install the collector cover.

21) Change the front hood damper bolt mounting position from (B) to (A), and completely close the front hood.

Tightening torque:

20 N·m (2.0 kgf-m, 14.8 ft-lb)

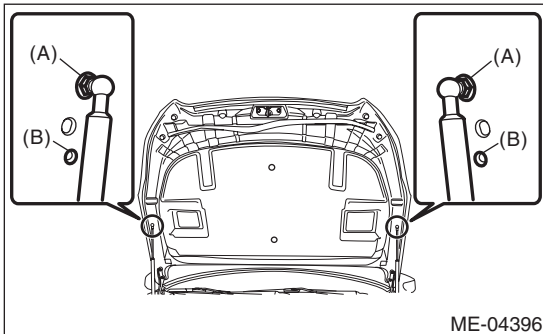

C: INSPECTION

Check that the front mount and front mount bracket have no deformation, cracks and other damages.