

16. Cam Sprocket

A: REMOVAL

- 1) Remove the V-belts. <Ref. to ME(H6DO)-51, REMOVAL, V-belt.>
- 2) Remove the crank pulley. <Ref. to ME(H6DO)-52, REMOVAL, Crank Pulley.>
- 3) Remove the chain cover. <Ref. to ME(H6DO)-53, REMOVAL, Chain Cover.>
- 4) Remove the timing chain assembly. <Ref. to ME(H6DO)-63, REMOVAL, Timing Chain Assembly.>
- 5) Use the ST to lock the cam sprocket, and remove the cam sprocket bolt.

ST 499977500 CAM SPROCKET WRENCH

- IN side

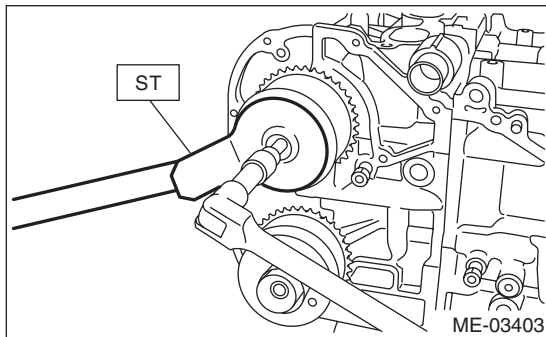

- EX side

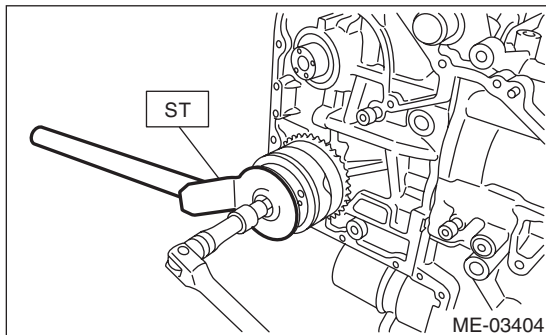

- 6) Remove the cam sprocket.

B: INSTALLATION

- 1) Install the cam sprocket.
- 2) Use the ST to lock the cam sprocket, and install the cam sprocket bolt.

Tightening torque:

Tighten to 29.5 N·m (3.0 kgf·m, 21.8 ft·lb) of torque, and then tighten further by 45°.

ST 499977500 CAM SPROCKET WRENCH

- IN side

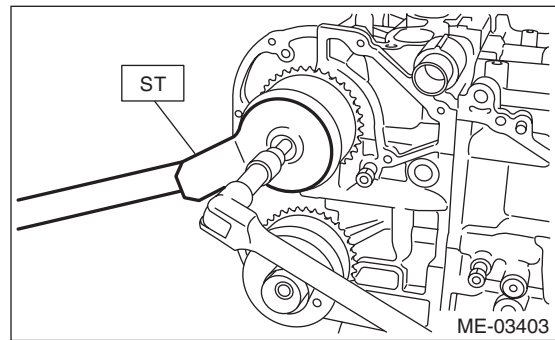

- EX side

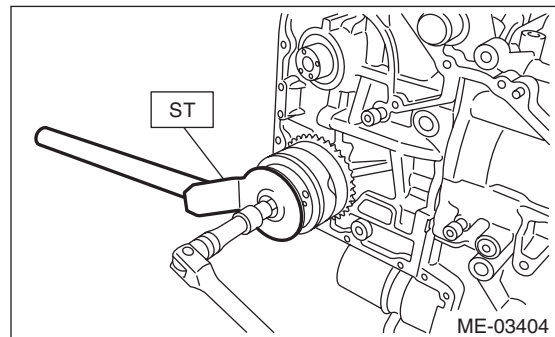

- 3) Install the timing chain assembly. <Ref. to ME(H6DO)-69, INSTALLATION, Timing Chain Assembly.>
- 4) Install the chain cover. <Ref. to ME(H6DO)-56, INSTALLATION, Chain Cover.>
- 5) Install the crank pulley. <Ref. to ME(H6DO)-52, INSTALLATION, Crank Pulley.>
- 6) Install the V-belts. <Ref. to ME(H6DO)-51, INSTALLATION, V-belt.>

C: INSPECTION

- 1) Check the cam sprocket teeth for abnormal wear and scratches.
- 2) Make sure there is no free play between cam sprocket and key.