

# Front Brake Pad

## BRAKE

### 2. Front Brake Pad

#### A: REMOVAL

- 1) Lift up the vehicle, and then remove the front wheels.
- 2) Remove the front brake pad.
  - (1) Remove the caliper bolt.
  - (2) Raise the caliper body and support it.

#### NOTE:

Do not disconnect the brake hose from the caliper body.

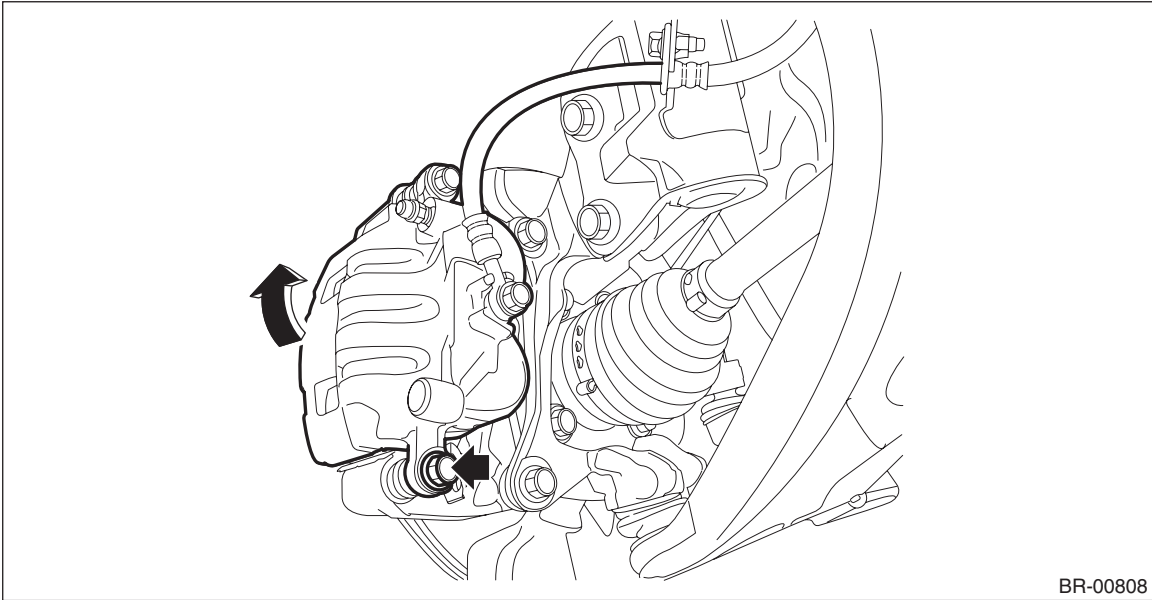

- (3) Remove the brake pad from support.

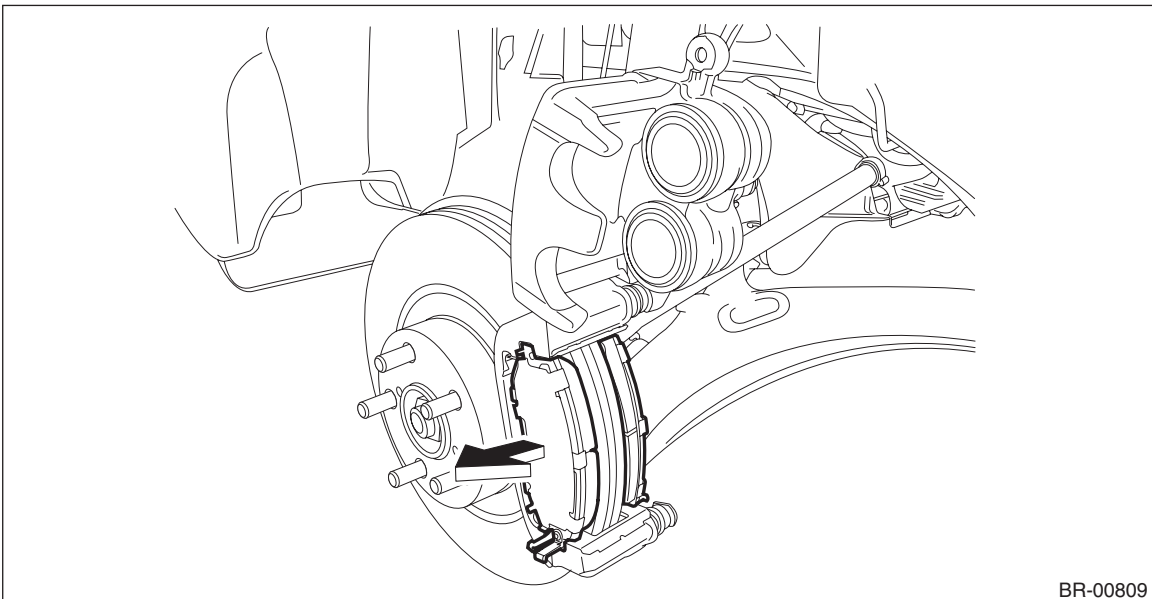

#### B: INSTALLATION

#### NOTE:

Before installation, remove mud and foreign matter from the caliper body and support.

- 1) Before installation, check the brake pad. <Ref. to BR-16, INSPECTION, Front Brake Pad.>

2) Apply a thin coat of grease contained in the pad kit to the pad clip.

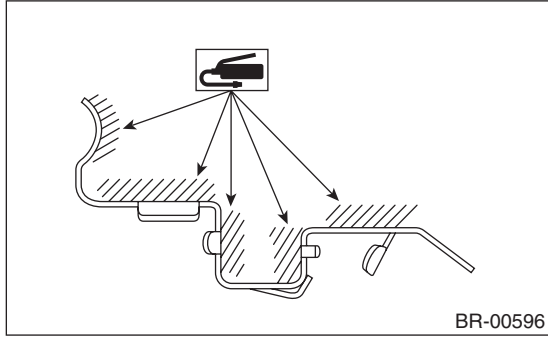

3) Apply a thin coat of Molykote AS880N (Part No. K0777YA010) or grease contained in the pad kit to both surfaces of the pad and inner shim.

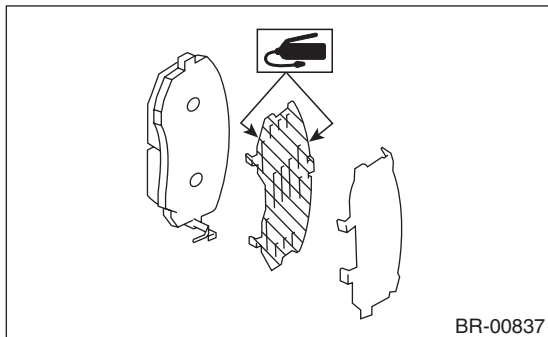

4) Install the brake pad to the support.

**CAUTION:**

- Be sure to install so that the pad return spring faces the input side of the direction of brake rotor rotation, as shown in the figure.
- Correctly install the pad return spring to the supporting surface of the pad clip as shown in the figure.
- If the pad return spring is deformed or damaged, replace the brake pad.

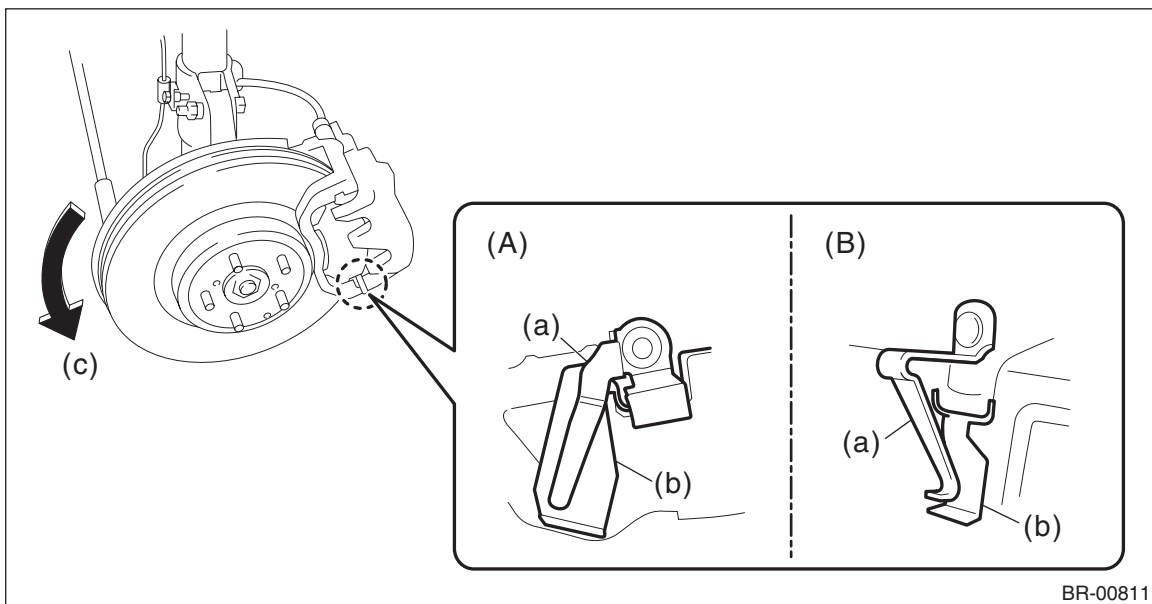

(A) 16-inch

(B) 17-inch

(a) Pad return spring

(b) Supporting surface of pad clip

(c) Direction of brake rotor rotation

# Front Brake Pad

## BRAKE

### NOTE:

Install the brake pad indicator in proper direction.

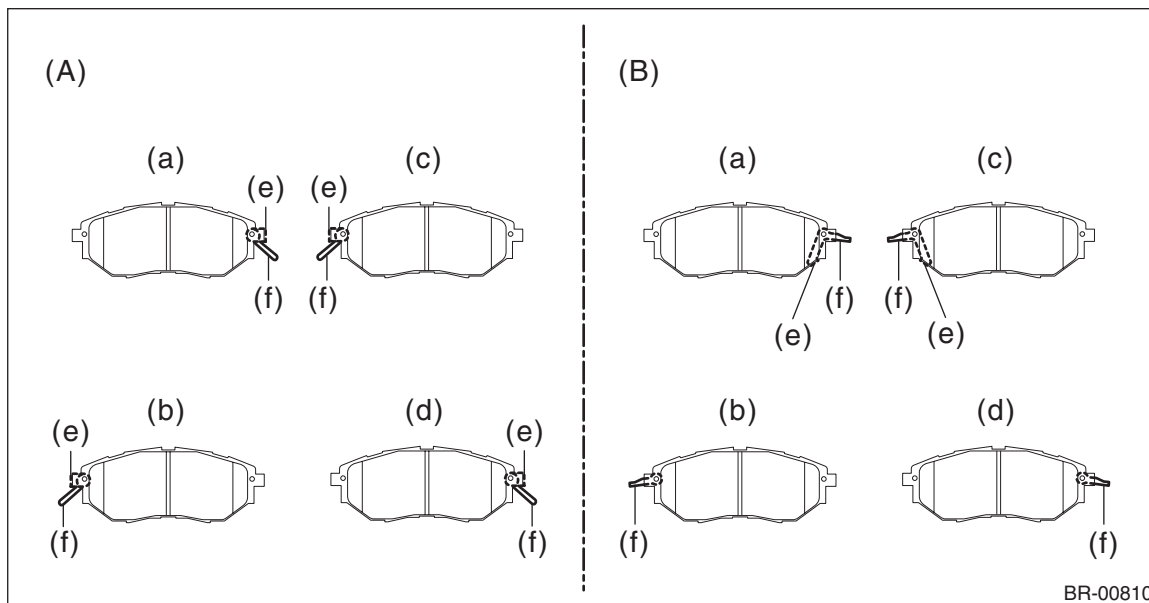

(A) 16-inch

(B) 17-inch

(a) LH — IN

(c) RH — IN

(e) Pad indicator

(b) LH — OUT

(d) RH — OUT

(f) Pad return spring

5) Install the caliper body to the support.

6) Install the front wheels.

### Tightening torque:

**Caliper bolt: 27 N·m (2.75 kgf-m, 19.9 ft-lb)**

## C: INSPECTION

1) Check the pad thickness (A).

### NOTE:

- Always replace the pads of both wheels and both sides as a set.
- Replace pad clips if they are twisted or worn.
- Replace the pad if there is oil or grease on it.

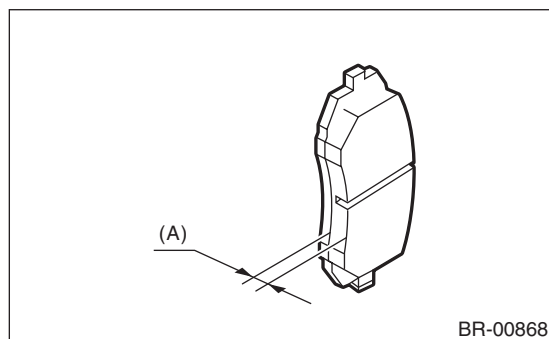

	Standard	Wear limit
Pad thickness (A)	11 mm (0.43 in)	1.5 mm (0.059 in)

2) If the wear limit is exceeded in the inspection, replace the brake pad.