

Front Disc Brake Assembly

BRAKE

4. Front Disc Brake Assembly

A: REMOVAL

CAUTION:

Do not allow brake fluid to come in contact with the painted surface of the vehicle body. If it does, wash off with water and wipe away completely.

- 1) Lift up the vehicle, and then remove the front wheels.
- 2) Remove the caliper body.
 - (1) Remove the union bolt and caliper bolt, and remove the caliper body from the support.

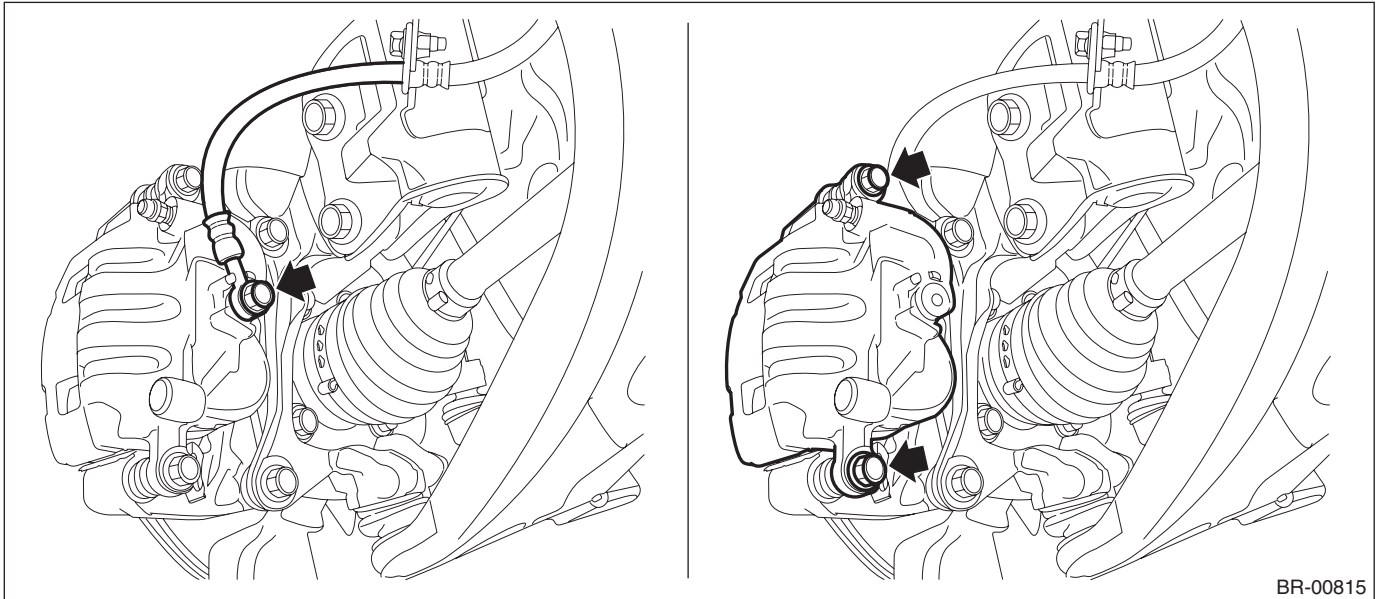

- 3) Remove the support.

NOTE:

Remove the support only when replacing the disc rotor or support. It is not necessary to remove it when servicing the caliper body.

- (1) Remove the brake pad from support.

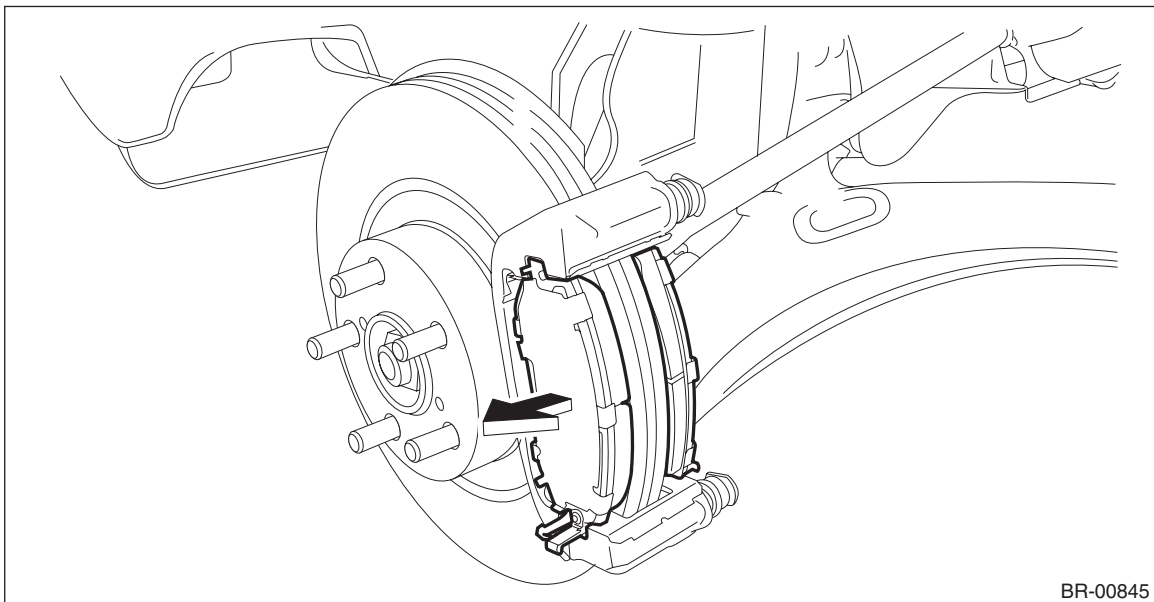

(2) Remove the mounting bolts, and then remove the support from the front axle housing.

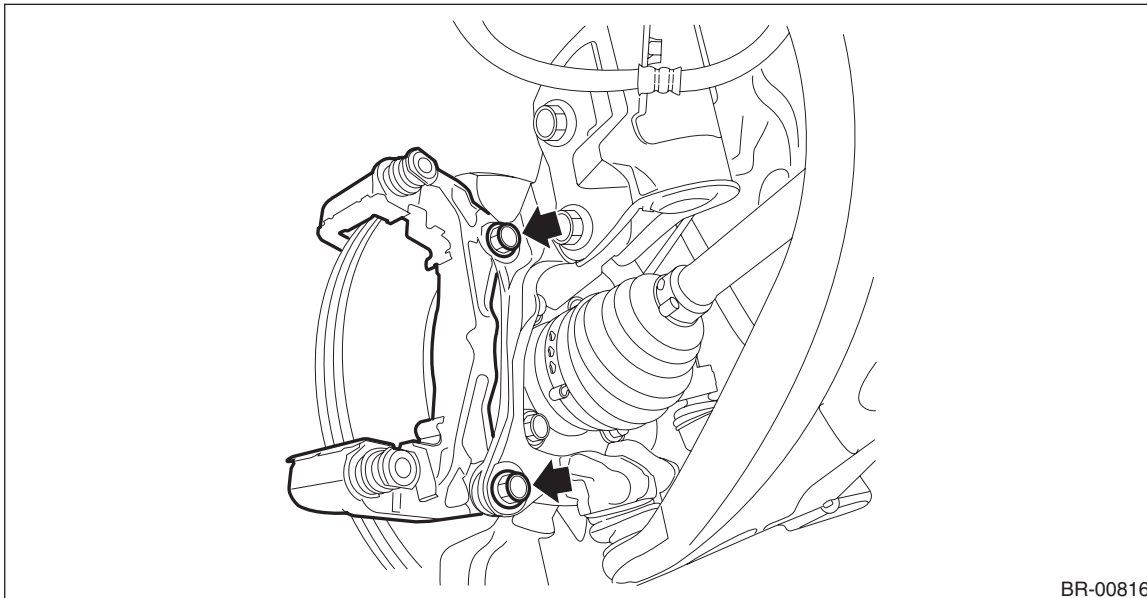

B: INSTALLATION

NOTE:

Before installation, remove mud and foreign matter from the caliper body and support.

1) Before installation, check each part. <Ref. to BR-26, INSPECTION, Front Disc Brake Assembly.>

2) Apply a thin coat of grease to the support.

Grease:

Grease contained in the pad kit or WAKO grease V160

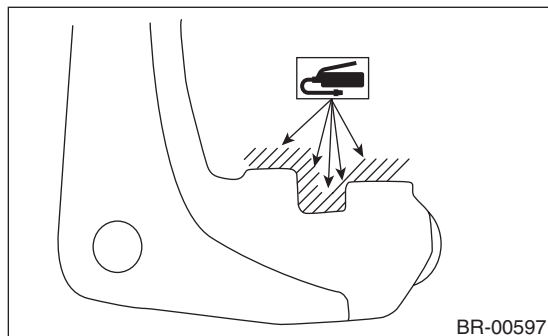

3) Install the support to the front axle housing.

Tightening torque:

Mounting bolt: 120 N·m (12.24 kgf-m, 88.5 ft-lb)

4) Apply a thin coat of grease contained in the pad kit to the pad clip.

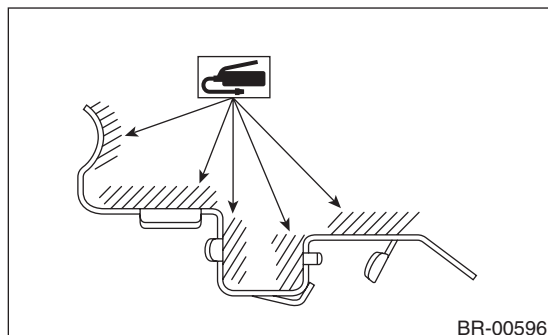

Front Disc Brake Assembly

BRAKE

5) Apply a thin coat of Molykote AS880N (Part No. K0777YA010) or grease contained in the pad kit to both surfaces of the pad and inner shim.

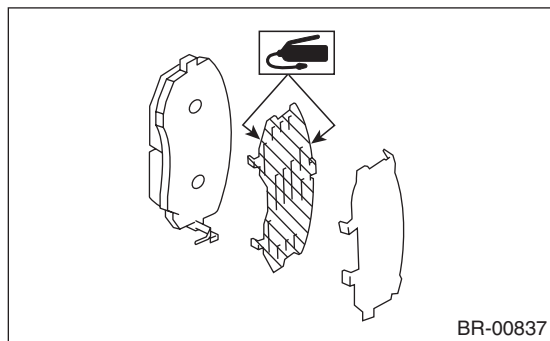

6) Install the brake pad to the support.

CAUTION:

- Be sure to install so that the pad return spring faces the input side of the direction of brake rotor rotation, as shown in the figure.
- Correctly install the pad return spring to the supporting surface of the pad clip as shown in the figure.
- If the pad return spring is deformed or damaged, replace the brake pad.

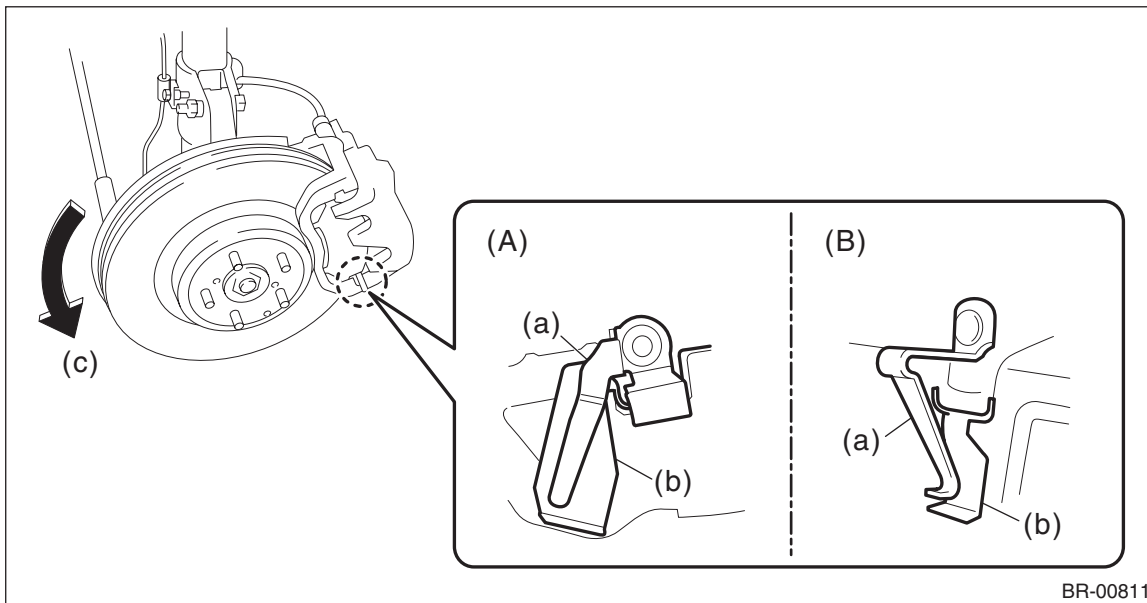

(A) 16-inch

(B) 17-inch

(a) Pad return spring

(b) Supporting surface of pad clip

(c) Direction of brake rotor rotation

Front Disc Brake Assembly

BRAKE

NOTE:

Install the brake pad indicator in proper direction.

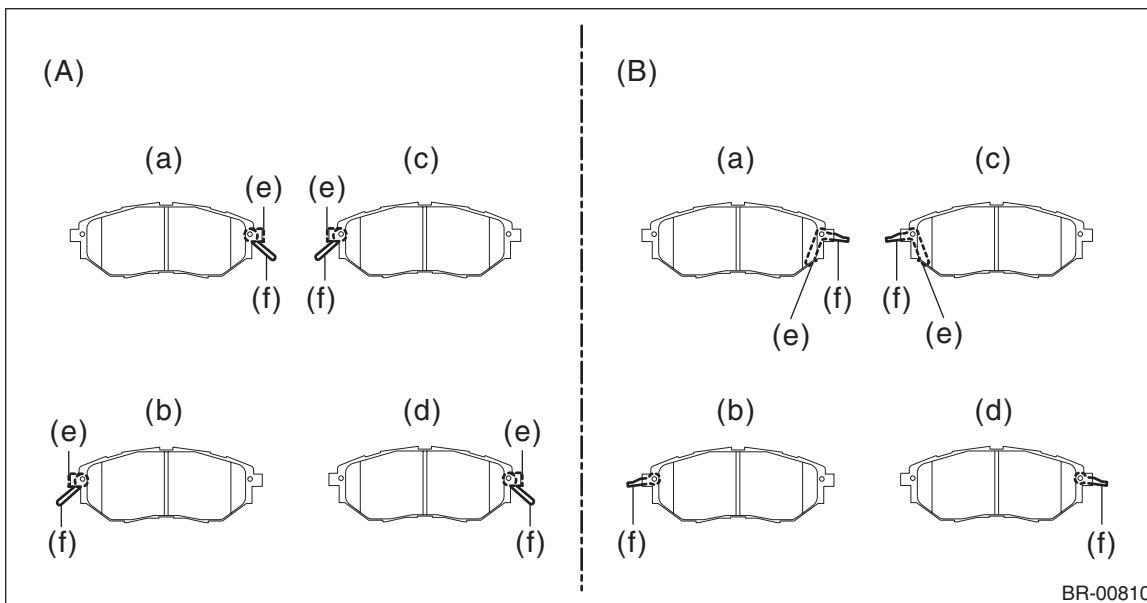

BR-00810

(A) 16-inch

(B) 17-inch

(a) LH — IN

(c) RH — IN

(e) Pad indicator

(b) LH — OUT

(d) RH — OUT

(f) Pad return spring

7) Install the caliper body to the support.

Tightening torque:

Caliper bolt: 27 N·m (2.75 kgf-m, 19.9 ft-lb)

8) Connect the brake hose using a new brake hose gasket.

Tightening torque:

Union bolt: 18 N·m (1.84 kgf-m, 13.3 ft-lb)

9) Bleed air from the brake system. <Ref. to BR-52, BRAKE LINE, PROCEDURE, Air Bleeding.>

10) Install the front wheels.

Front Disc Brake Assembly

BRAKE

C: DISASSEMBLY

CAUTION:

Be careful not to allow foreign matter to enter the brake hose connector.

- 1) Remove mud and foreign matter from the caliper body.
- 2) Remove the piston.
 - (1) Place a wooden block in the caliper body as shown in the figure to prevent the piston from jumping out and being damaged.
 - (2) Using an air gun, gradually apply compressed air via the brake hose installation hole to push the piston out.

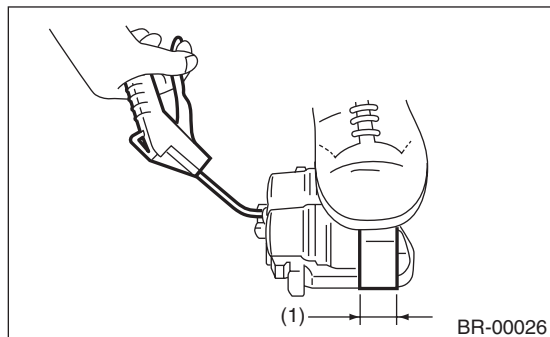

- (1) Place a wooden block of 30 mm (1.18 in) width.

- 3) Remove the piston boot from caliper body cylinder.

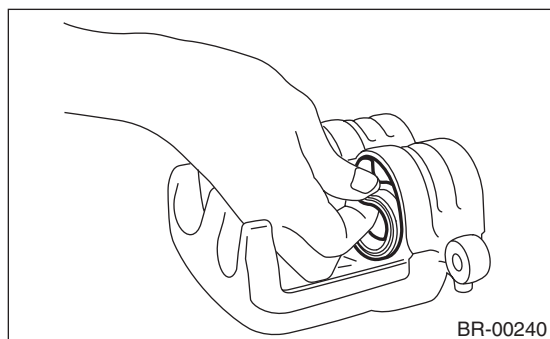

- 4) Remove the piston seal from caliper body cylinder.

CAUTION:

Do not damage the cylinder and piston seal groove.

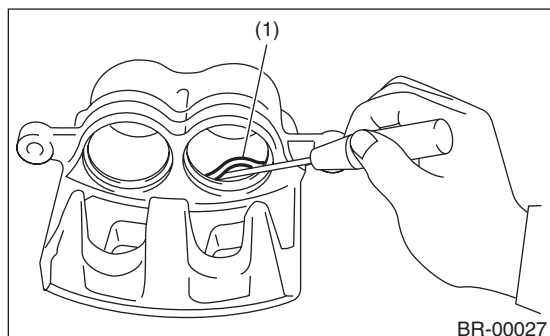

- (1) Piston seal

5) Remove the guide pin, lock pin, bushing pin, and pin boot from the support.

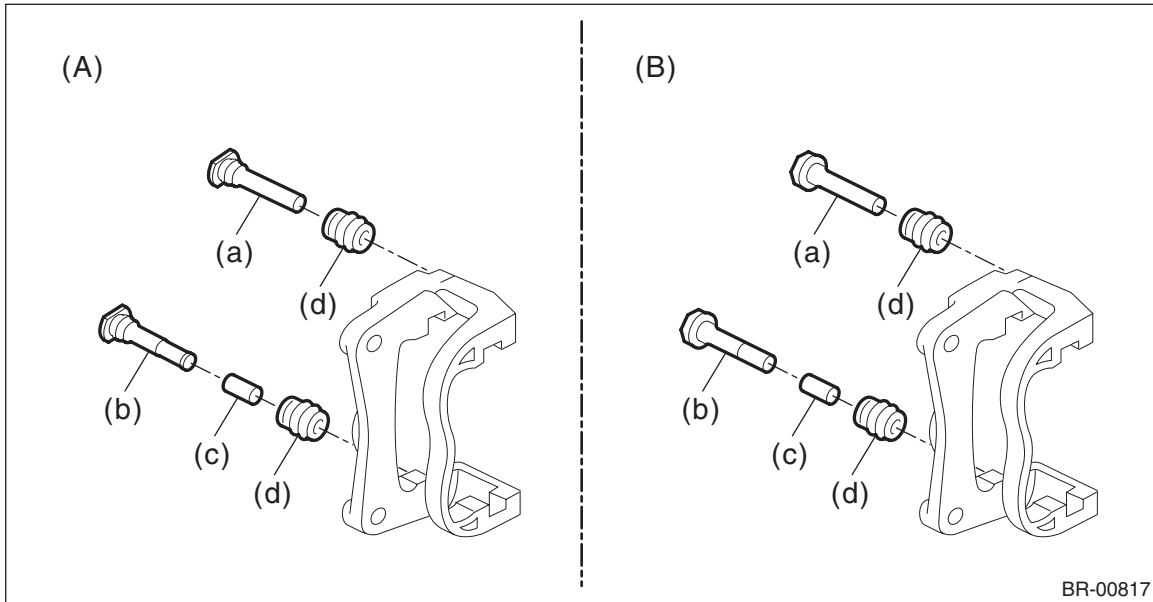

(A) 16-inch

(B) 17-inch

(a) Guide pin (black)

(c) Bushing

(d) Pin boot

(b) Lock pin (silver)

D: ASSEMBLY

- 1) Before assembly, check each part. <Ref. to BR-26, INSPECTION, Front Disc Brake Assembly.>
- 2) Clean the inside of the caliper body cylinder using brake fluid.
- 3) Apply a coat of brake fluid to piston seal and install the piston seal to the caliper body cylinder groove.
- 4) Apply a coat of brake fluid to the inner surface of caliper body cylinder and the entire outer surface of the piston.
- 5) Apply grease contained in the piston seal kit to the piston boot, and install it to the groove at the end of the cylinder.
- 6) Insert the piston into caliper body cylinder.

CAUTION:

Do not force the piston into caliper body cylinder.

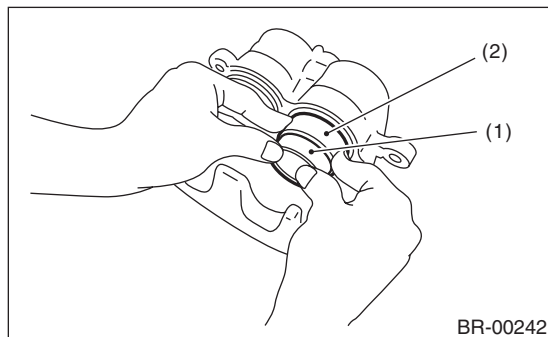

(1) Piston

(2) Piston boot

Front Disc Brake Assembly

BRAKE

7) Position the piston boot in the grooves on caliper body cylinder and piston.

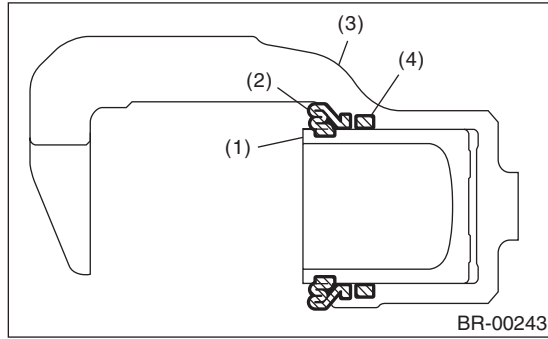

- (1) Piston
- (2) Piston boot
- (3) Caliper body
- (4) Piston seal

8) Apply grease contained in the piston seal kit to the lock pin, guide pin outer surface, support cylinder inner surface, and pin boot grooves.

9) Install the pin boot to the lock pin and guide pin, and insert it into the support cylinder.

CAUTION:

Insert the lock pin and guide pin into specified position, and make sure that they slide and seat properly.

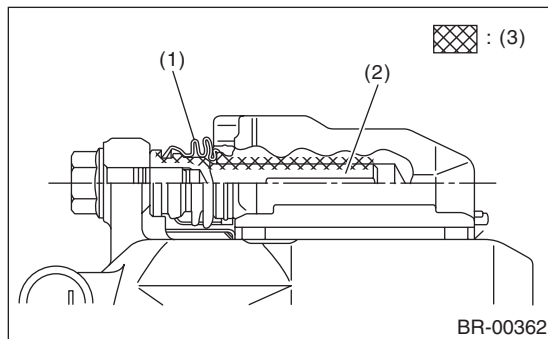

- (1) Pin boot
- (2) Lock pin or guide pin
- (3) Grease applied area

E: INSPECTION

- 1) Check the caliper body cylinder and piston for uneven wear, damage or rust.
- 2) Check the rubber parts for damage or deterioration.
- 3) If faulty is found in the inspection, replace the relevant part.