

6. Rear Differential Front Oil Seal

A: INSPECTION

Make sure that there is no leakage from front oil seal portion. If there is any leakage, replace the oil seal and inspect the propeller shaft.

B: REPLACEMENT

- 1) Shift the select lever or gear shift lever to neutral.
- 2) Release the parking brake.
- 3) Disconnect the ground cable from battery.
- 4) Lift up the vehicle.
- 5) Drain differential gear oil. <Ref. to DI-22, REPLACEMENT, Differential Gear Oil.>
- 6) Remove the rear exhaust pipe.
 - 2.5 L model
<Ref. to EX(H4DO)-13, REMOVAL, Rear Exhaust Pipe.>
 - 3.6 L model
<Ref. to EX(H6DO)-8, REMOVAL, Rear Exhaust Pipe.>
- 7) Remove the heat shield cover.

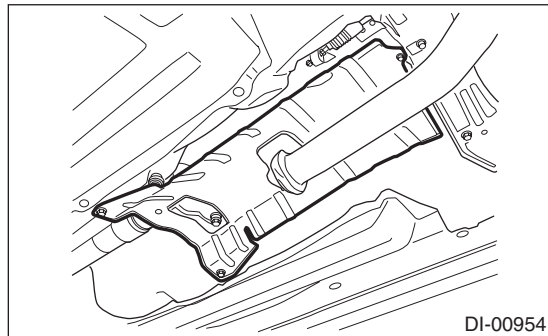

- 8) Remove the propeller shaft. <Ref. to DS-10, REMOVAL, Propeller Shaft.>
 - 9) Check the initial torque and write it down.
 - 10) Remove the self-locking nut while holding the companion flange with ST.
- ST 498427200 FLANGE WRENCH

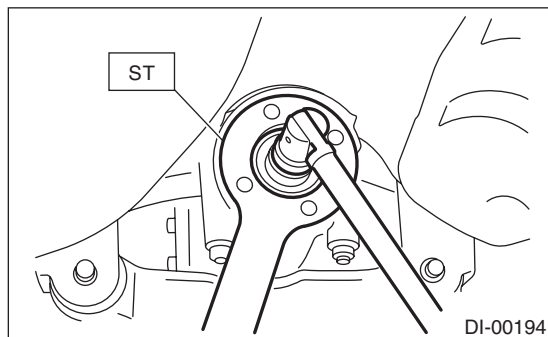

- 11) Extract the companion flange using the ST.
- ST 399703600 PULLER ASSY

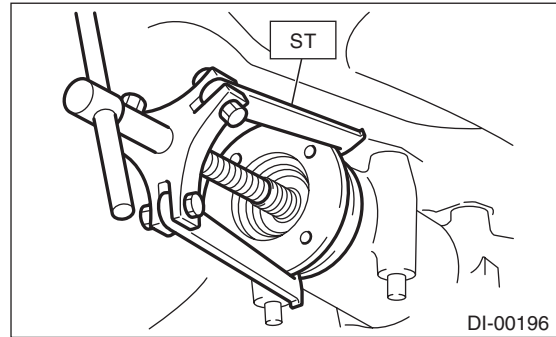

- 12) Remove the oil seal using ST or screwdriver.
- ST 398527700 PULLER ASSY

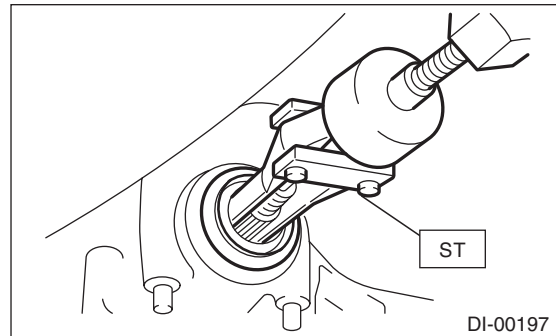

- 13) Using the ST, install the oil seal.

NOTE:

- Use a new oil seal.
 - Apply differential gear oil to the oil seal lips.
- ST 498447120 INSTALLER

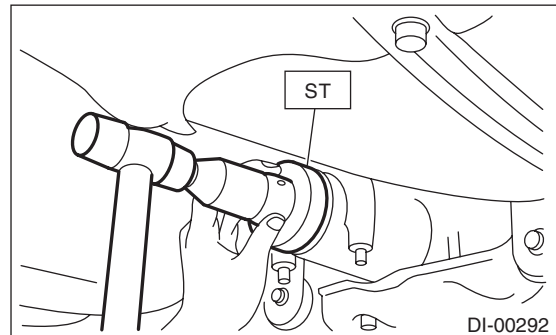

Rear Differential Front Oil Seal

DIFFERENTIALS

14) Install the companion flange.

NOTE:

Use a plastic hammer to install companion flange.

15) Tighten the self-locking nut to the specified torque so that the initial torque of companion flange becomes the same as that of before oil seal replacement.

NOTE:

- Use a new self-locking nut.
- Before installing the self-locking nut, apply the seal material to the threads of the drive pinion shaft and to the seating surface of the self-locking nut.

Seal material:

THREE BOND 1324 (Part No. 004403042) or equivalent

Tightening torque:

T-type

167 — 196 N·m (17.0 — 20.0 kgf-m, 123.2 — 144.6 ft-lb)

VA-type

162 — 220 N·m (16.5 — 22.5 kgf-m, 119.5 — 162.3 ft-lb)

ST 498427200 FLANGE WRENCH

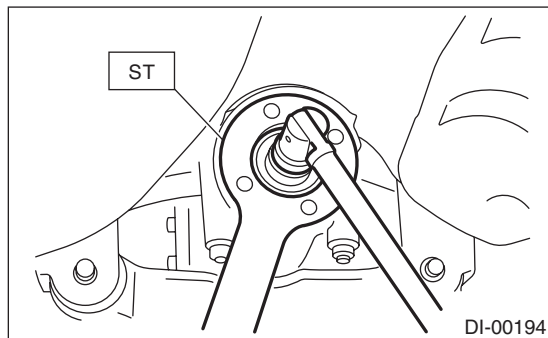

16) Hereafter, perform assembly in the reverse order of disassembly.

17) Fill differential gear oil. <Ref. to DI-22, REPLACEMENT, Differential Gear Oil.>