

4. Front Hub Unit Bearing

A: REMOVAL

- 1) Lift up the vehicle, and then remove the front wheels.
- 2) Remove the axle nut.

CAUTION:

Do not loosen the axle nut while the front axle is loaded. Doing so may damage the hub bearing.

- (1) Lift the crimped section of axle nut.
- (2) Remove the axle nut using a socket wrench while depressing the brake pedal.

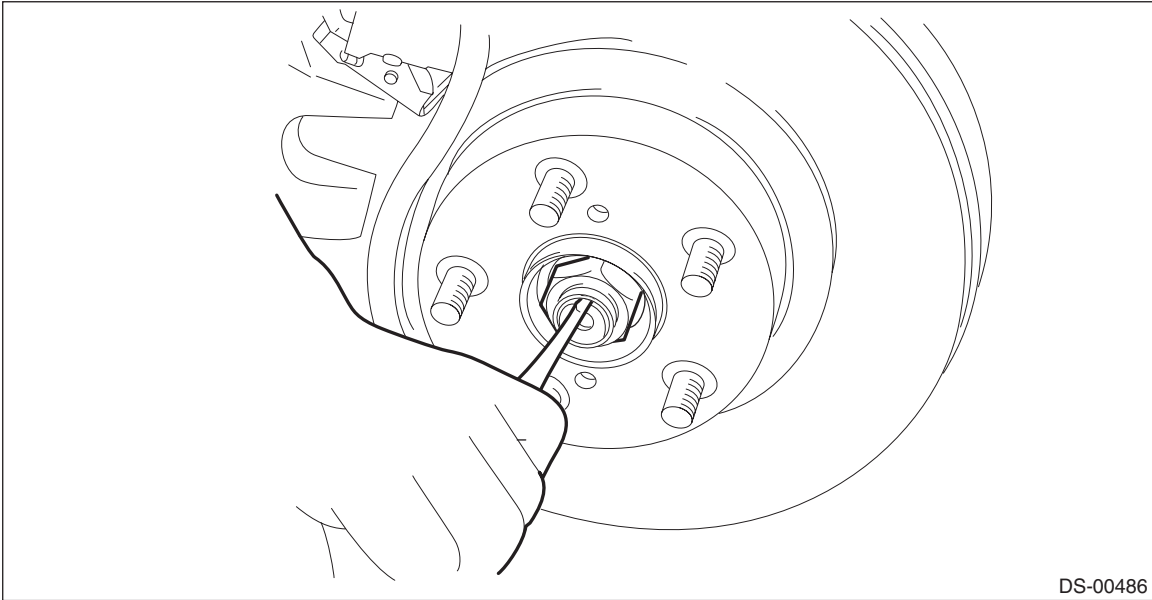

- 3) Remove the front ABS wheel speed sensor.

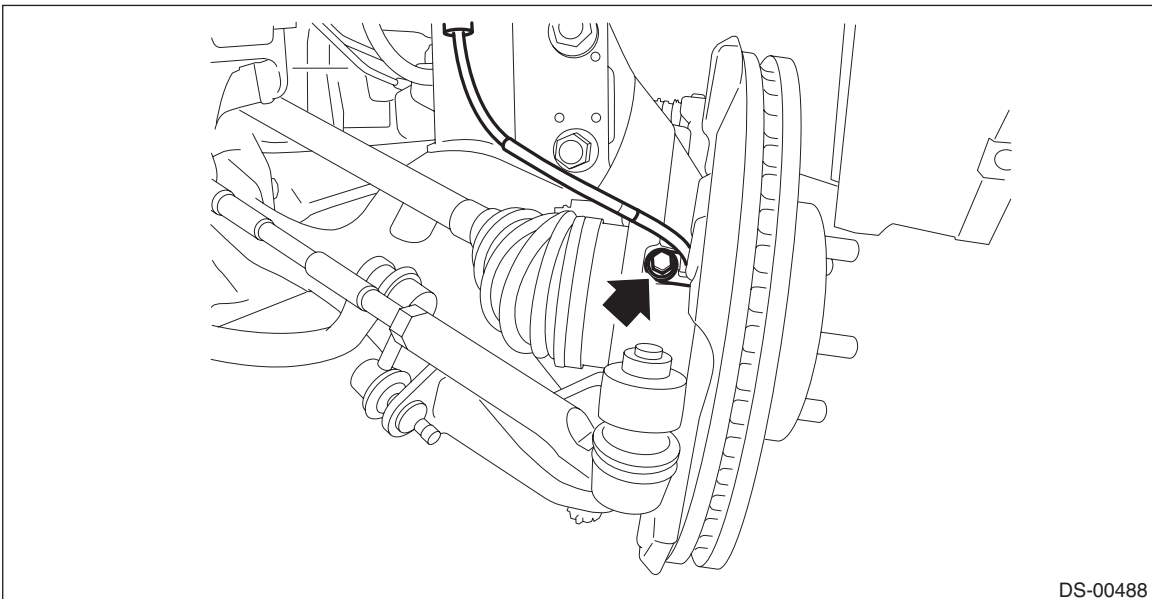

Front Hub Unit Bearing

DRIVE SHAFT SYSTEM

- 4) Remove the front disc brake caliper from the front axle housing.
- (1) Remove the mounting bolts, and then remove the front disc brake caliper.
 - (2) Prepare wiring harnesses etc. to be discarded, and suspend the front disc brake caliper from the shock absorber with the harnesses.

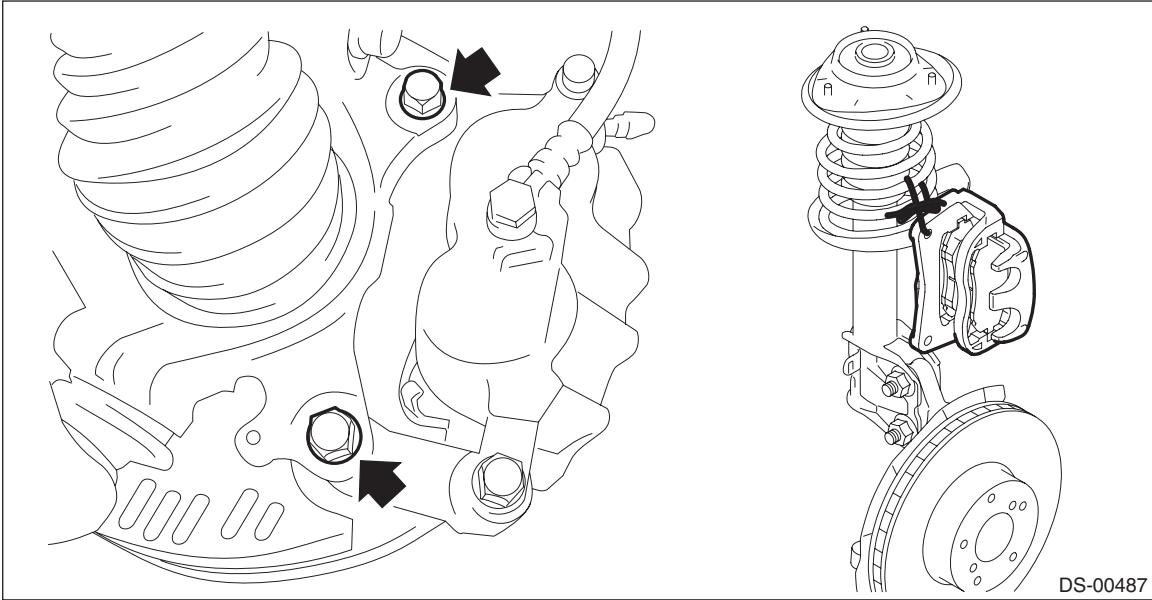

- 5) Remove the disc rotor.

NOTE:

When the disc rotor is difficult to be removed from the front hub unit bearing, screw in 8 mm (0.31 in) bolt to the threaded part of the disc rotor (A), and remove the disc rotor.

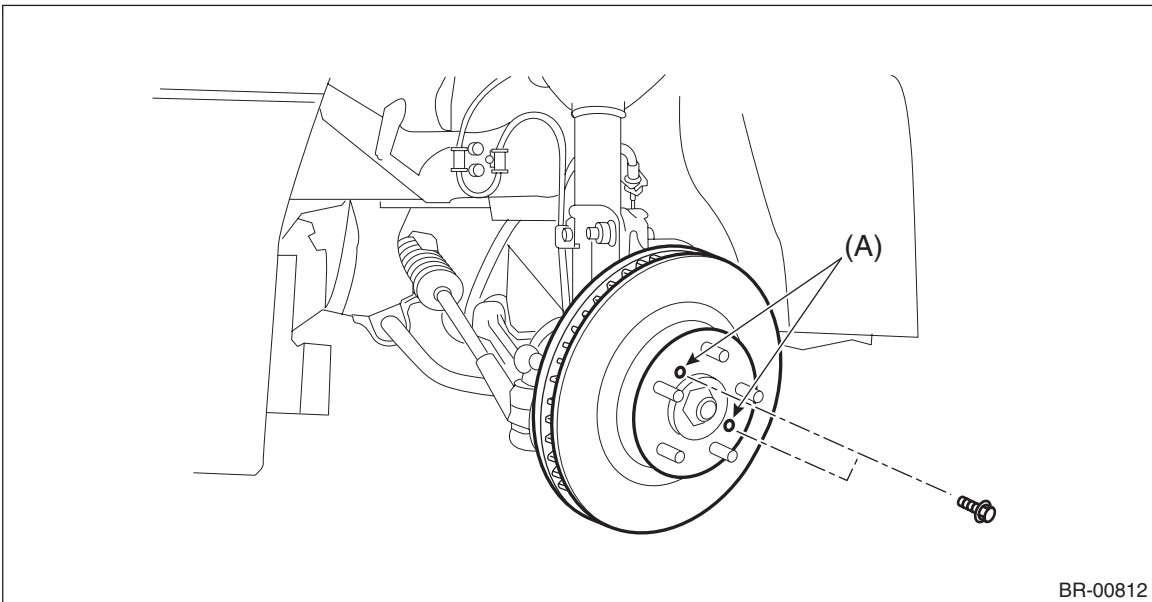

6) Remove the bolt from the front axle housing.

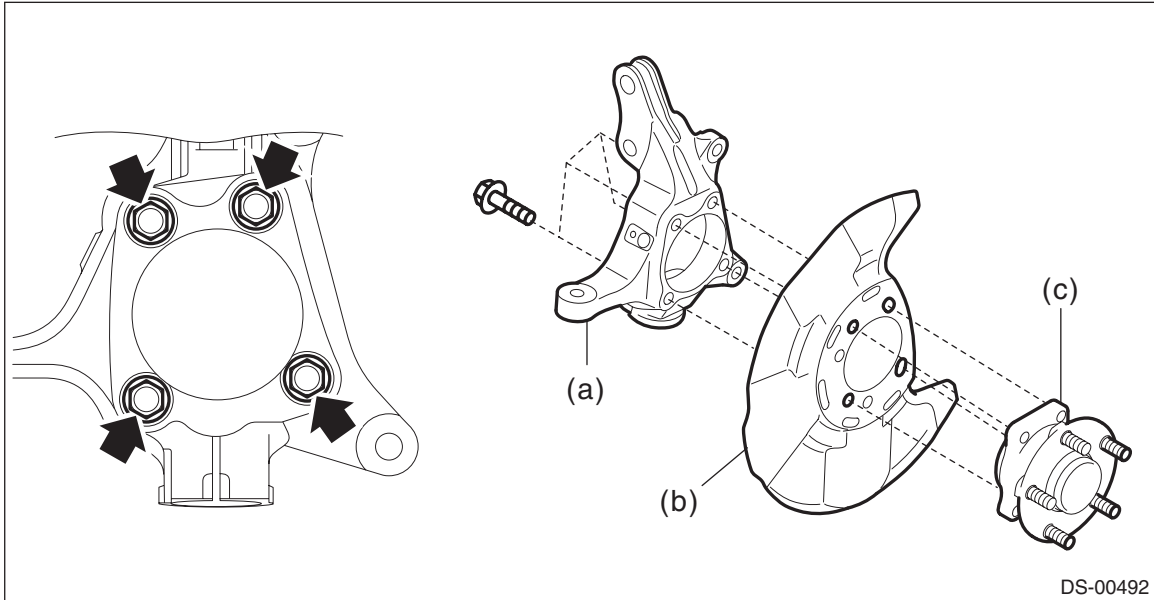

(a) Front axle housing

(b) Disc brake cover

(c) Front hub unit bearing

CAUTION:

- Do not get closer the tool which charged magnetism to magnetic encoder.
- Be careful not to damage the magnetic encoder.

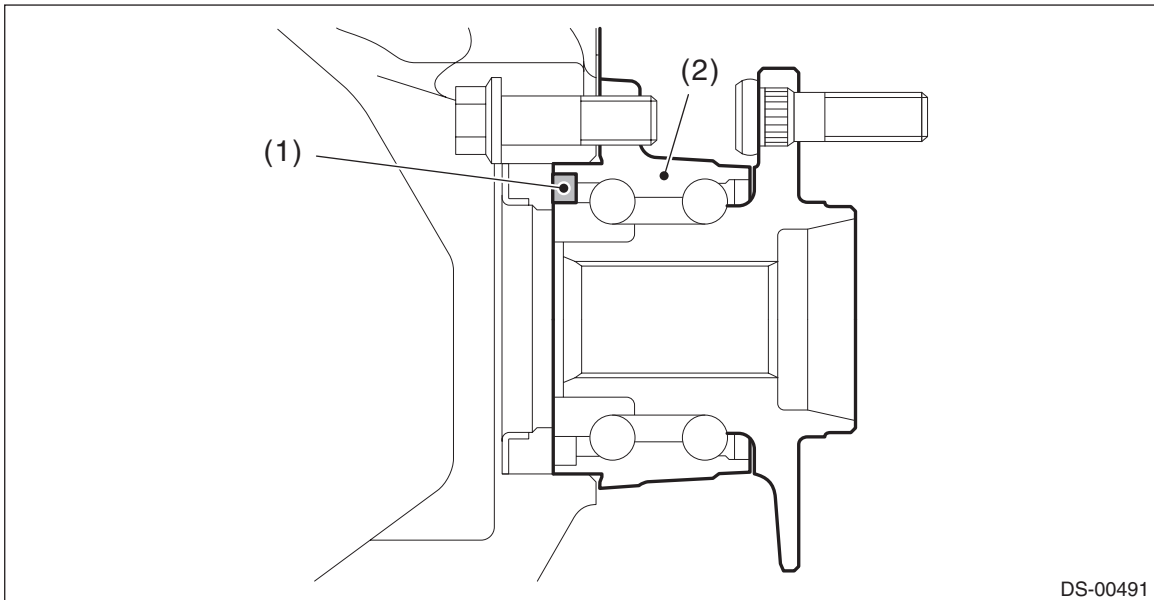

(1) Magnetic encoder

(2) Front hub unit bearing

Front Hub Unit Bearing

DRIVE SHAFT SYSTEM

7) Remove the front hub unit bearing. If it is hard to remove, use the ST.

PREPARATION TOOL:

ST1: AXLE SHAFT PULLER (926470000)

ST2: AXLE SHAFT PULLER PLATE (28099PA110)

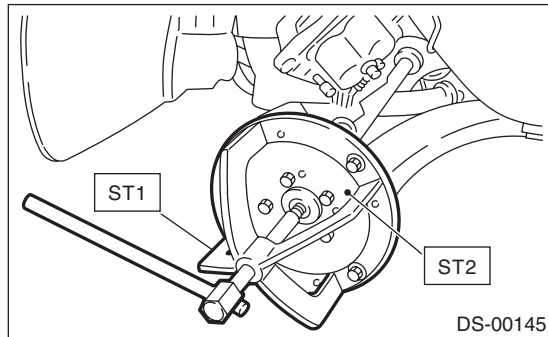

B: INSTALLATION

1) Install the front axle housing (a) and front hub unit bearing (c) to the disc brake cover (b) as shown in the figure, and tighten the bolt.

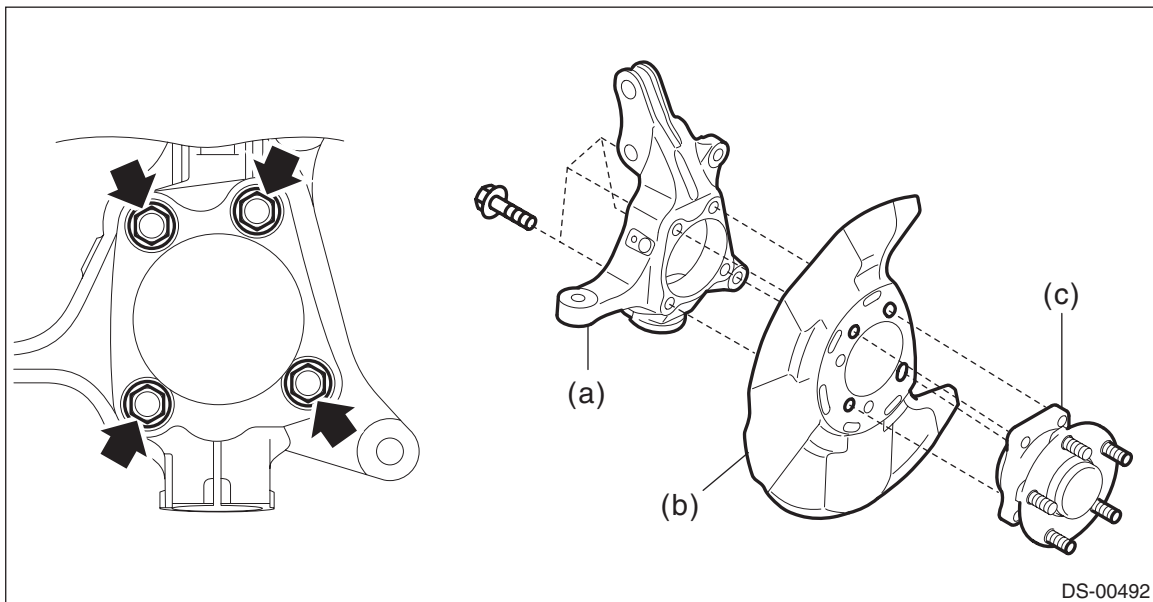

Tightening torque:

65 N·m (6.63 kgf·m, 47.9 ft·lb)

2) Install the front drive shaft. <Ref. to DS-49, INSTALLATION, Front Drive Shaft.>

3) Tighten the axle nut temporarily.

4) Install the disc rotor to hub unit bearing.

5) Install the disc brake caliper to the front axle housing.

Tightening torque:

120 N·m (12.24 kgf·m, 88.5 ft·lb)

6) Install the front ABS wheel speed sensor.

Tightening torque:

7.5 N·m (0.76 kgf·m, 5.5 ft·lb)

7) While pressing the brake pedal, tighten the new axle nuts to the specified torque.

CAUTION:

Do not load the front axle before tightening the axle nut. Doing so may damage the hub bearing.

Tightening torque:

220 N·m (22.43 kgf·m, 162.3 ft·lb)

8) Inspect the lean of axis direction using a dial gauge. Replace the bearing if the load range exceeds the limitation.

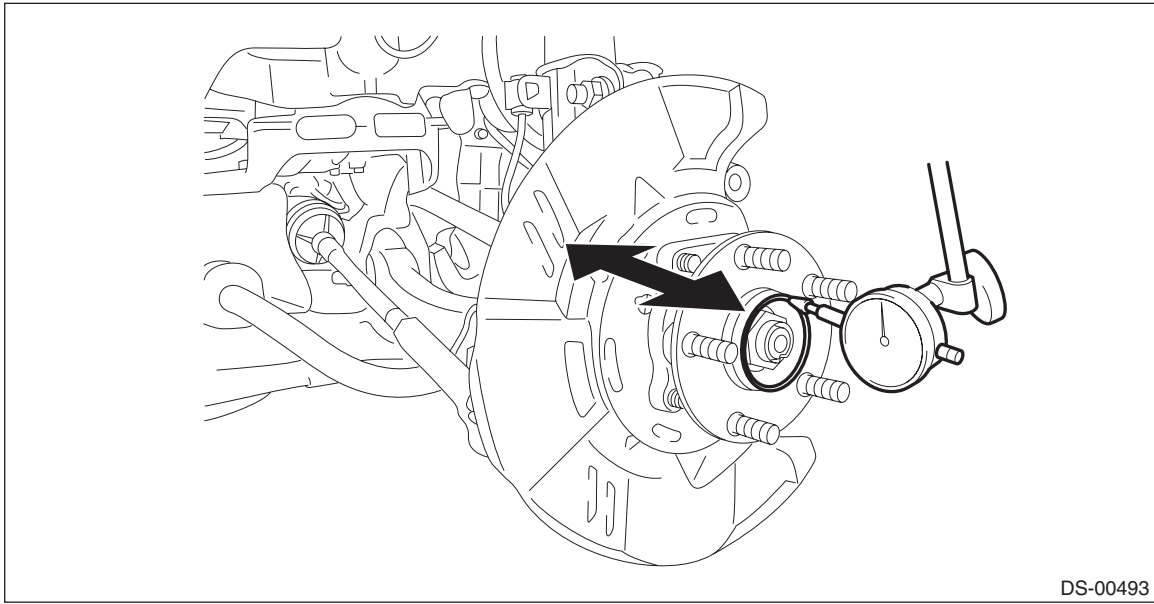

Service limit:

Maximum: 0.05 mm (0.0020 in)

9) After tightening the axle nut, lock it securely.

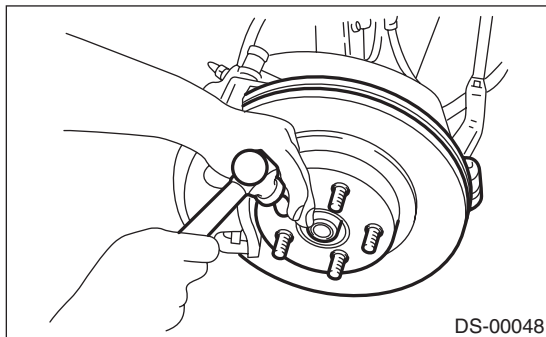

10) Install the wheel.

Tightening torque:

120 N·m (12.24 kgf·m, 88.5 ft·lb)

11) Moving the front tire up and down by hand, check there is no play in bearing, and check the wheel rotates smoothly.

CAUTION:

If there is any fault in the bearing, replace hub unit bearing.

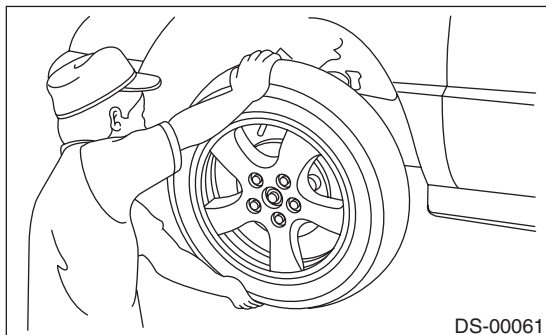

Front Hub Unit Bearing

DRIVE SHAFT SYSTEM

C: DISASSEMBLY

Using the ST or a hydraulic press, push out the hub bolt (b) from the front hub unit bearing (a).

CAUTION:

- Be careful not to hammer the hub bolts. This may deform the hub.
- Do not reuse the hub bolt.

PREPARATION TOOL:

ST: HUB STAND (28399AG000)

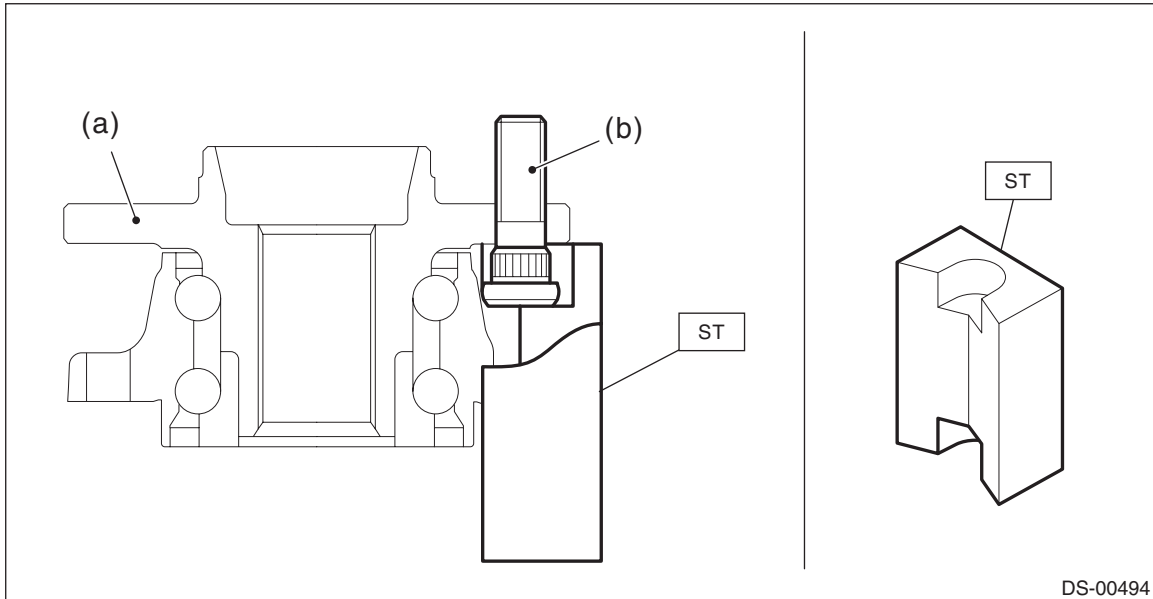

DS-00494

NOTE:

Since the hub unit bearing can not be disassembled, only hub bolts can be removed.

D: ASSEMBLY

1) Install the hub unit bearing to the ST securely.

PREPARATION TOOL:

ST: HUB STAND (927080000)

2) Using a press, press the new hub bolts (b) until their seating surfaces contact the hub unit bearing (a).

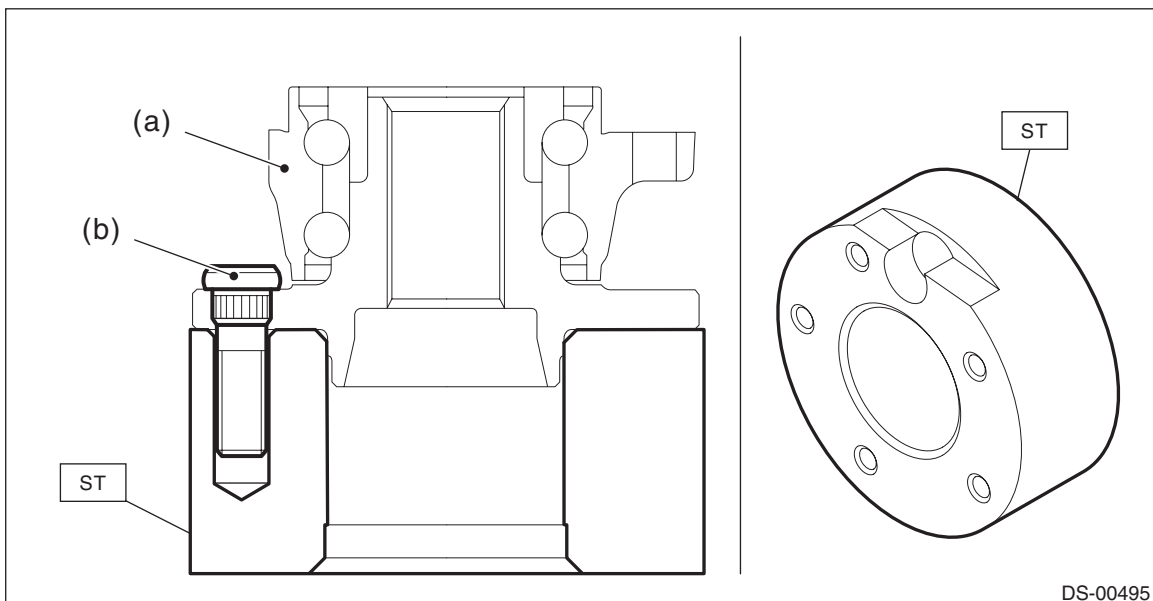

DS-00495

NOTE:

Use the 12 mm (0.47 in) dia. holes in the HUB STAND to prevent bolts from tilting.

E: INSPECTION

1) Moving the front tire up and down by hand, check there is no play in bearing, and check the wheel rotates smoothly.

CAUTION:

If there is any fault in the bearing, replace hub unit bearing.

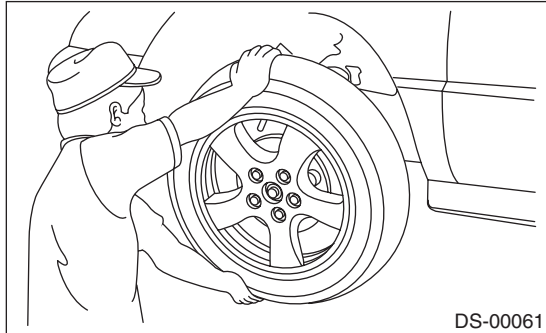

2) Inspect the lean of axis direction using a dial gauge. Replace the bearing if the load range exceeds the limitation.

Service limit:

Maximum: 0.05 mm (0.0020 in)

