

## 6. Rear Hub Unit Bearing

### A: REMOVAL

- 1) Lift up the vehicle, and then remove the rear wheels.
- 2) Remove the axle nut.

#### CAUTION:

**Do not loosen the axle nut while the rear axle is loaded. Doing so may damage the hub bearing.**

- (1) Lift the crimped section of axle nut.
- (2) Remove the axle nut using a socket wrench while depressing the brake pedal.

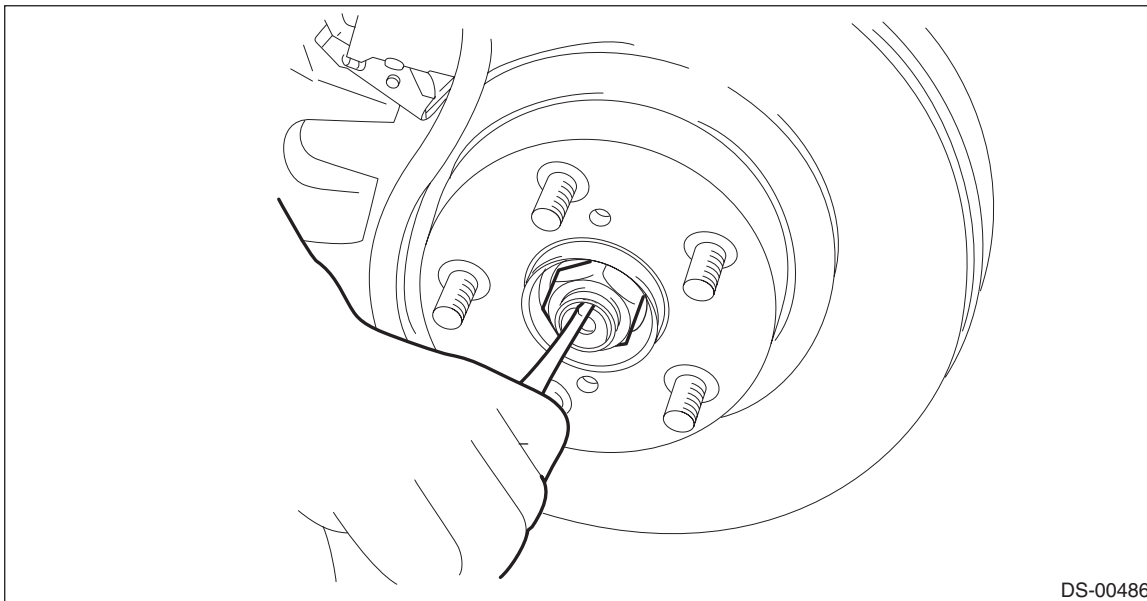

- 3) Remove the rear disc brake caliper from the rear axle housing.
  - (1) Remove the bolt from the brake hose bracket.
  - (2) Remove the mounting bolts, and then remove the rear disc brake caliper.

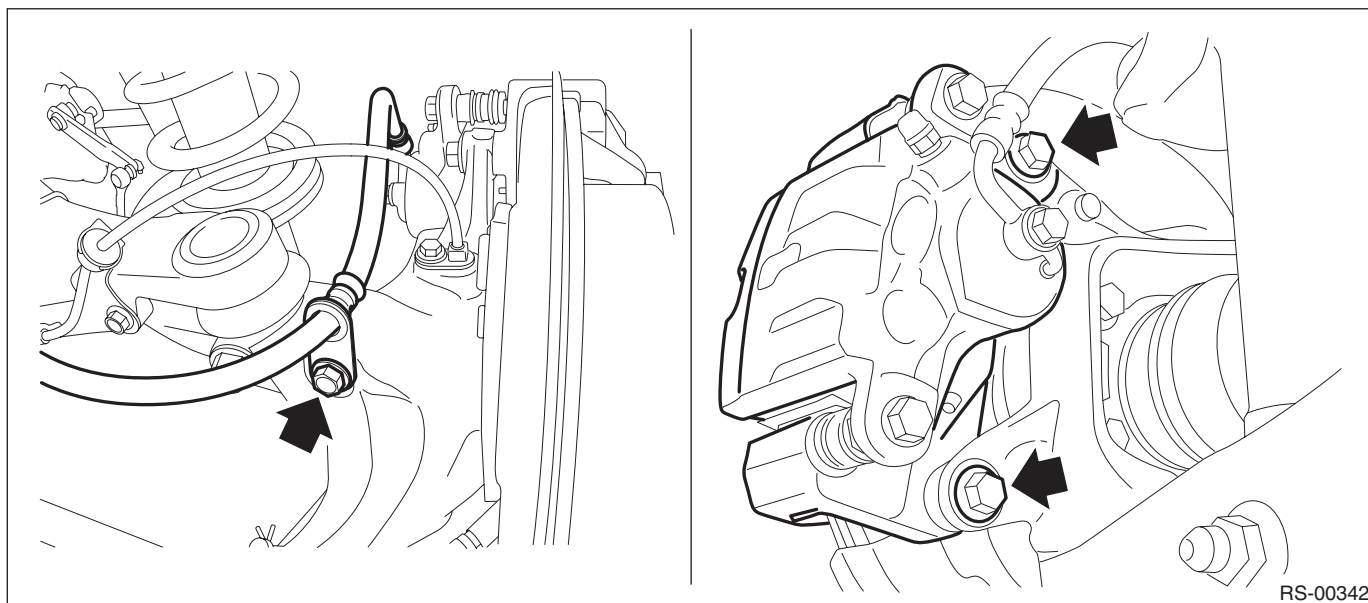

# Rear Hub Unit Bearing

## DRIVE SHAFT SYSTEM

(3) Prepare wiring harnesses etc. to be discarded, and suspend the rear disc brake caliper from the shock absorber with the harnesses.

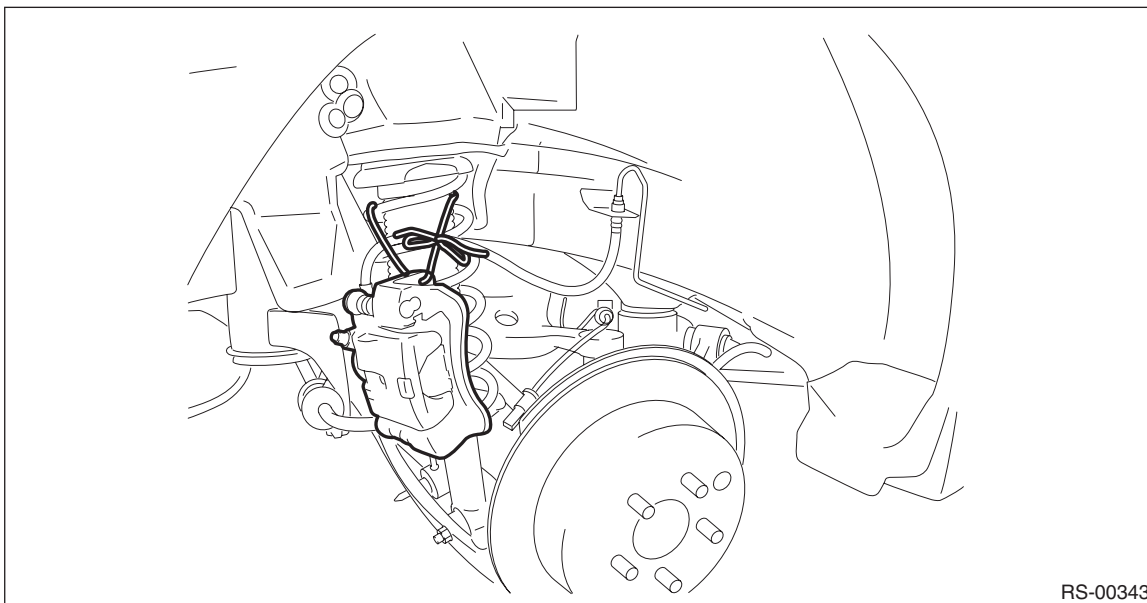

4) Remove the rear disc rotor.

### NOTE:

If it is difficult to remove the disc rotor, perform the following two methods in order.

1. Remove the adjusting hole cover (A), insert the flat tip screwdriver, and rotate the adjusting screw until the brake shoe moves far enough to remove the disc rotor.

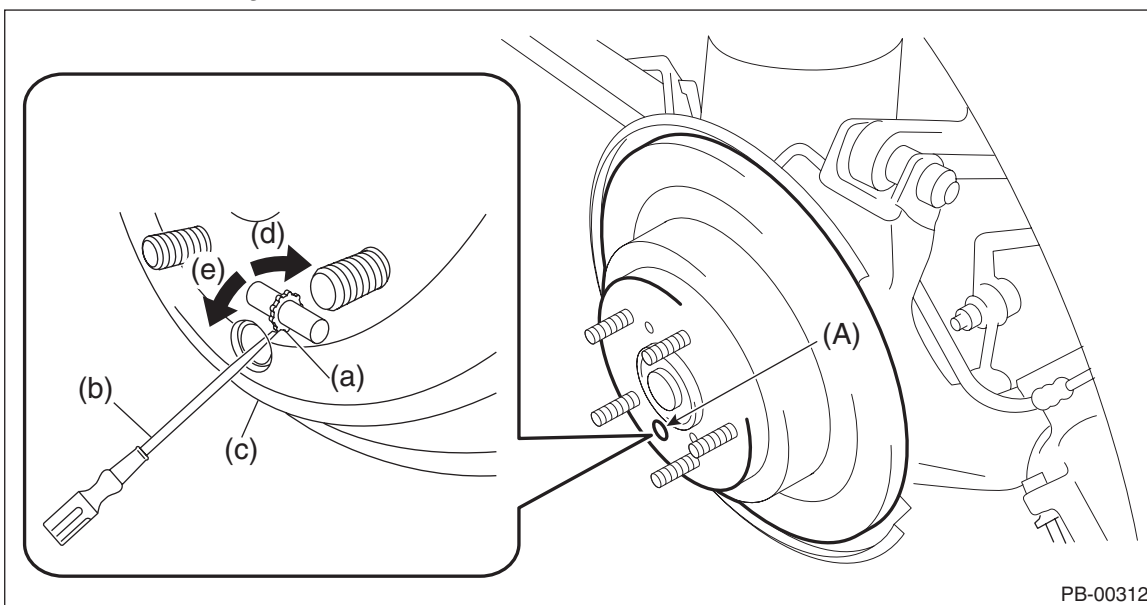

(a) Adjusting screw  
(b) Flat tip screwdriver

(c) Disc rotor  
(d) Extend the adjusting screw

(e) Shorten the adjusting screw

## Rear Hub Unit Bearing

DRIVE SHAFT SYSTEM

2. When the disc rotor is difficult to be removed from the rear hub unit bearing, screw in 8 mm (0.31 in) bolt to the threaded part of the disc rotor (A), and remove the disc rotor.

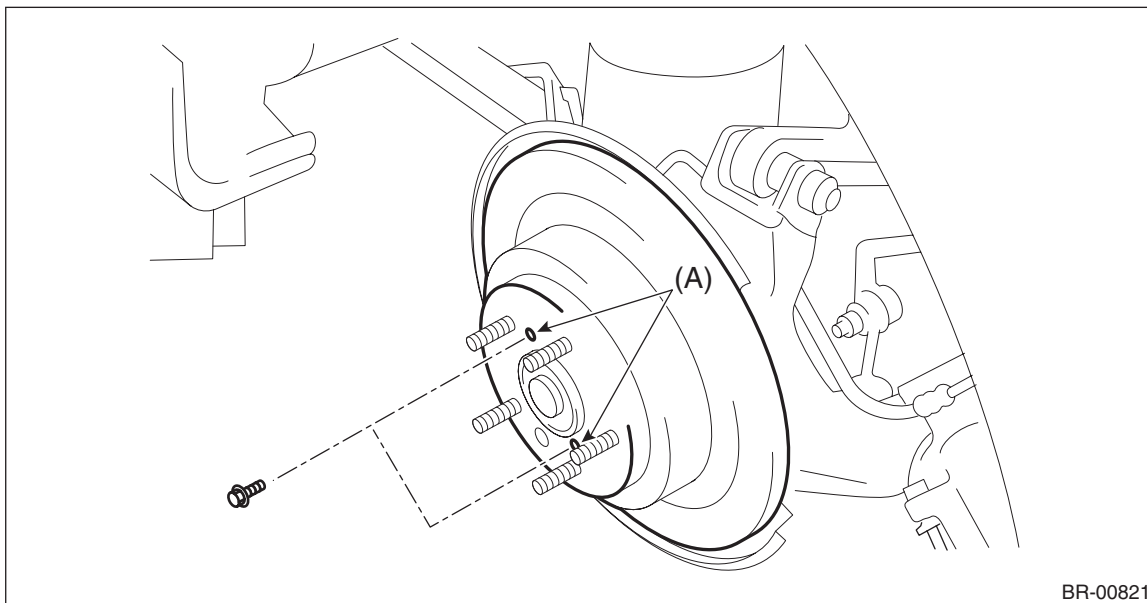

BR-00821

5) Remove the rear hub unit bearing.

### CAUTION:

- Be careful not to damage the magnetic encoder.
- Do not get closer the tool which charged magnetism to magnetic encoder.

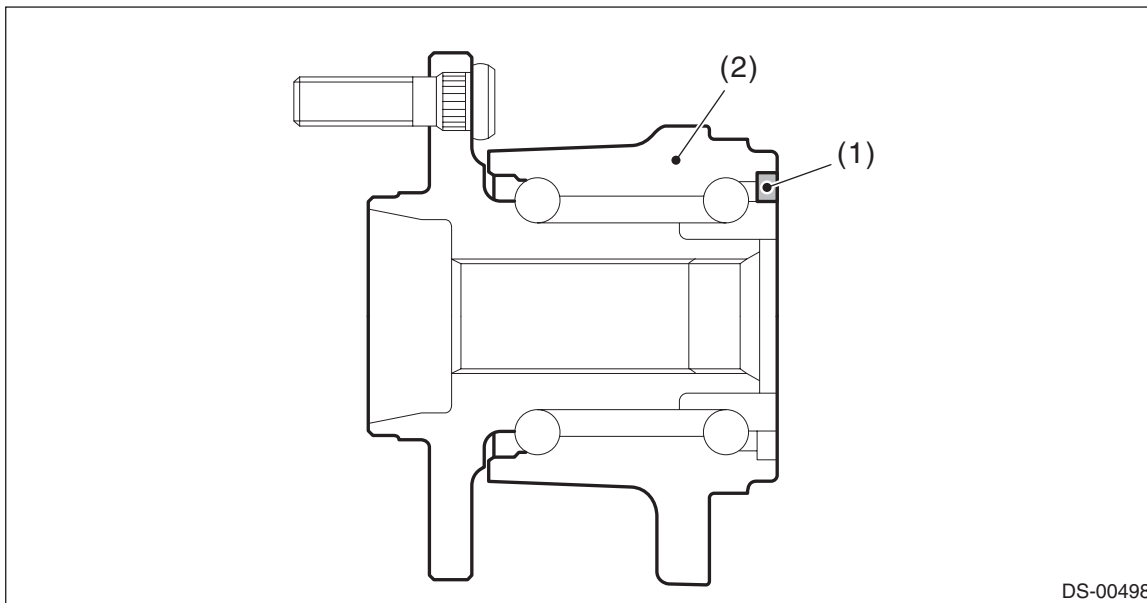

DS-00498

(1) Magnetic encoder

(2) Rear hub unit bearing

# Rear Hub Unit Bearing

## DRIVE SHAFT SYSTEM

(1) Remove the bolt from the rear axle housing.

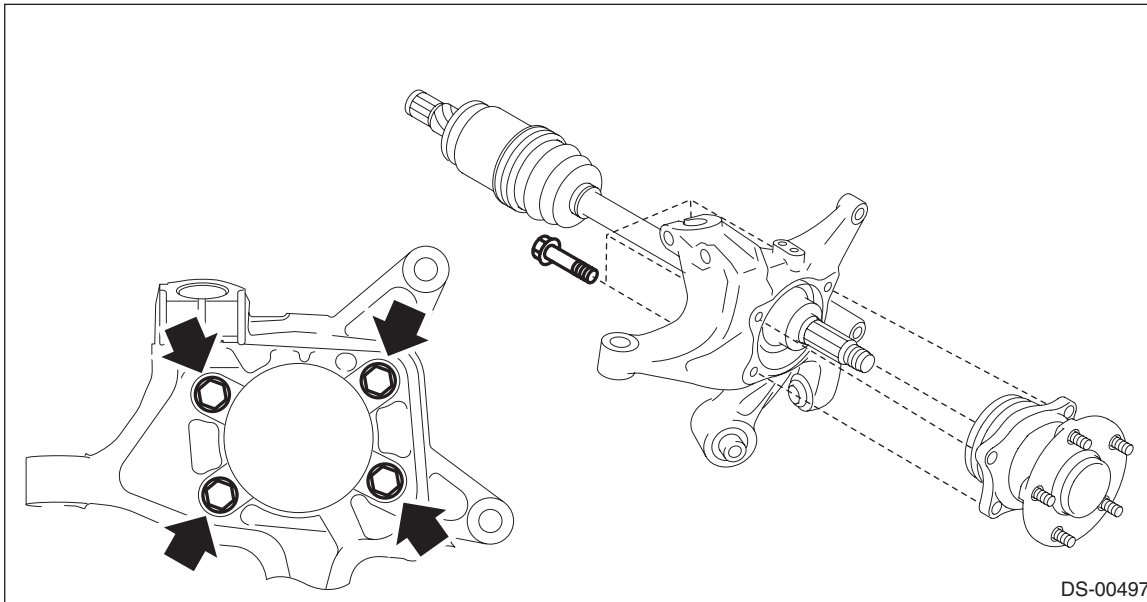

(2) Remove the rear hub unit bearing.

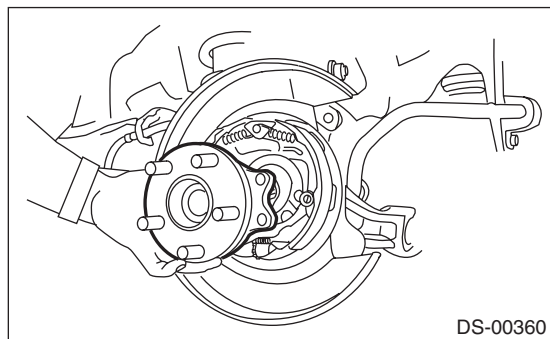

### NOTE:

If it is hard to remove, use the ST.

### Preparation tool:

**ST1: AXLE SHAFT PULLER (926470000)**

**ST2: AXLE SHAFT PULLER PLATE (28099PA110)**

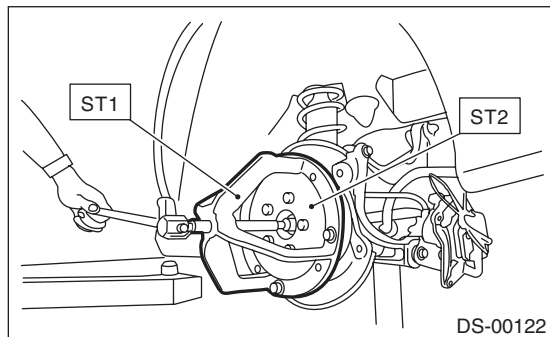

## B: INSTALLATION

1) Aligning with the mounting hole of the rear brake back plate, temporarily tighten the rear hub unit bearing to the rear axle housing.

### CAUTION:

- Be careful not to damage the magnetic encoder.
- Do not get closer the tool which charged magnetism to magnetic encoder.

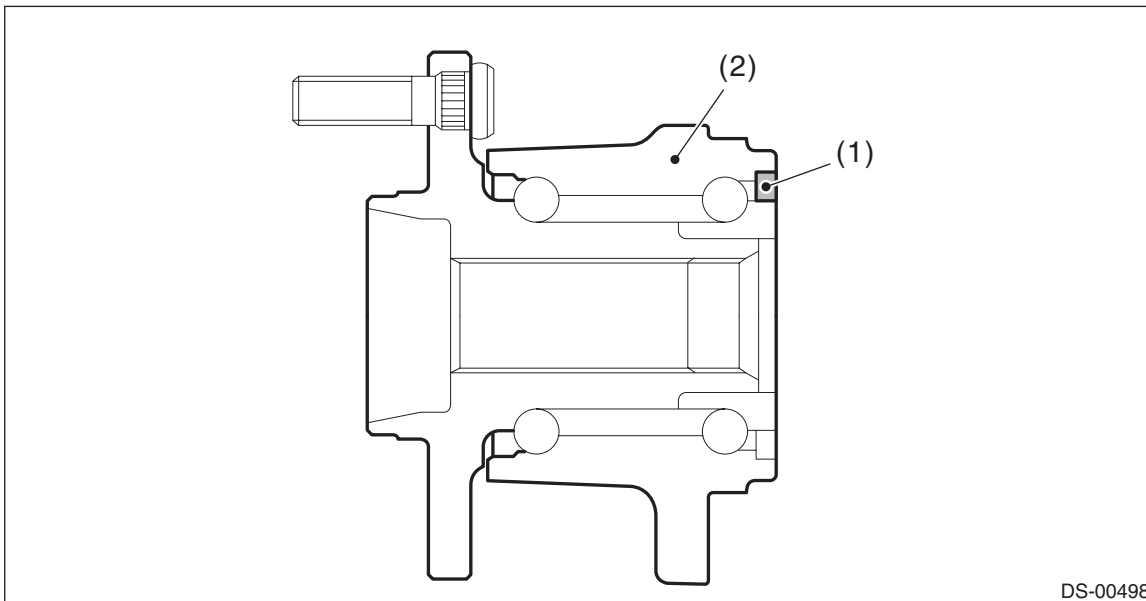

DS-00498

(1) Magnetic encoder

(2) Rear hub unit bearing

2) Tighten the rear hub unit bearing.

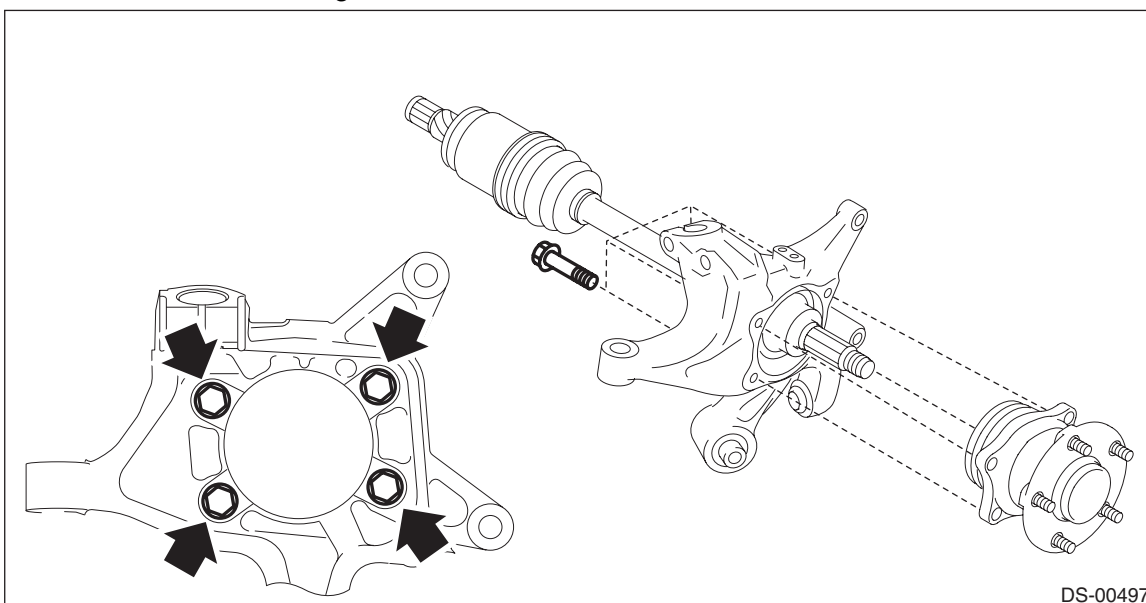

DS-00497

### Tightening torque:

**65 N·m (6.63 kgf-m, 47.9 ft-lb)**

3) Tighten the new axle nut temporarily.

### CAUTION:

**Use new axle nuts.**

4) Install the rear disc rotor.

## Rear Hub Unit Bearing

### DRIVE SHAFT SYSTEM

---

5) Install the disc brake.

**Tightening torque:**

**66 N·m (6.73 kgf·m, 48.7 ft·lb)**

6) While pressing the brake pedal, tighten the new axle nuts to the specified torque.

**CAUTION:**

**Do not load the rear axle before tightening the axle nut. Doing so may damage the hub bearing.**

**Tightening torque:**

**240 N·m (24.47 kgf·m, 177.0 ft·lb)**

7) Inspect the lean of axis direction using a dial gauge. Replace the bearing if the load range exceeds the limitation.

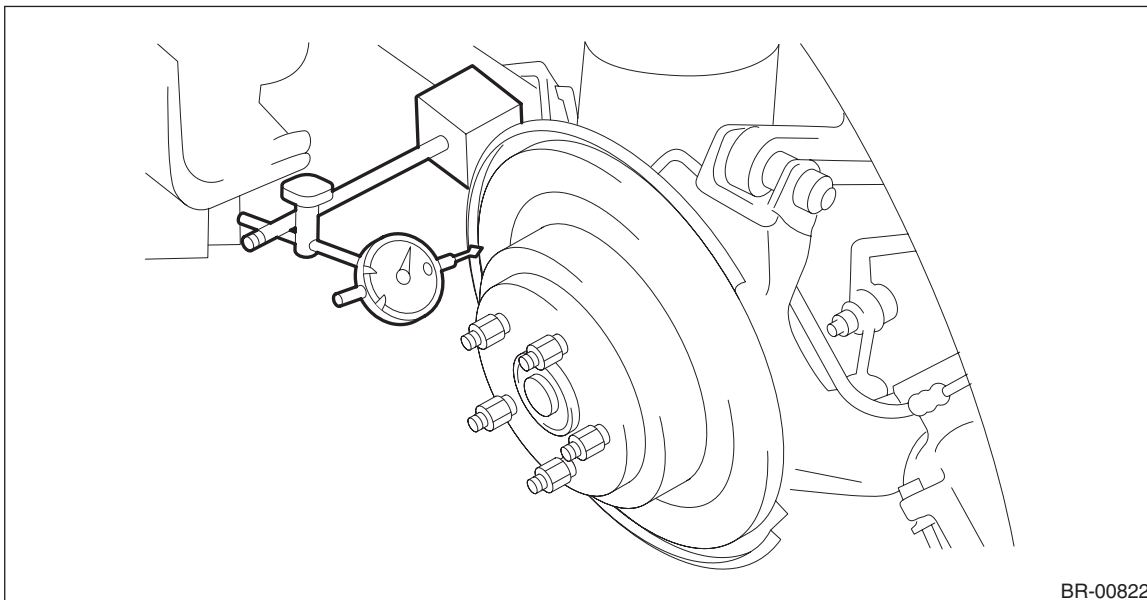

**Service limit:**

**Maximum: 0.05 mm (0.0020 in)**

8) After tightening the axle nut, lock it securely.

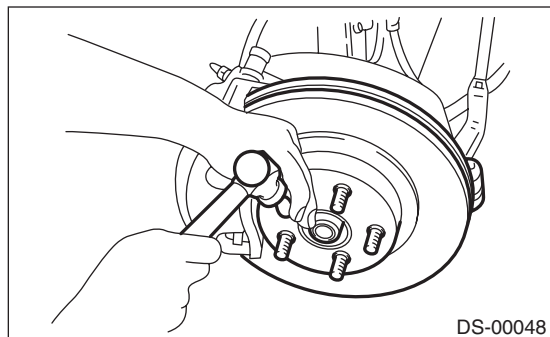

9) Install the rear wheels.

**Tightening torque:**

**120 N·m (12.24 kgf·m, 88.5 ft·lb)**

10) Moving the rear tire up and down by hand, check there is no backlash in bearing, and check the wheel rotates smoothly.

**CAUTION:**

**If there is any fault in the bearing, replace hub unit bearing.**

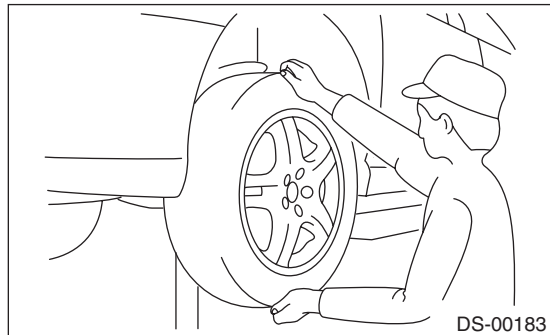

## C: DISASSEMBLY

Using the ST or a hydraulic press, push out the hub bolt (b) from the rear hub unit bearing (a).

**CAUTION:**

- Be careful not to hammer the hub bolts. This may deform the hub.
- Do not reuse the hub bolt.

**PREPARATION TOOL:**

**ST: HUB STAND (28399AG000)**

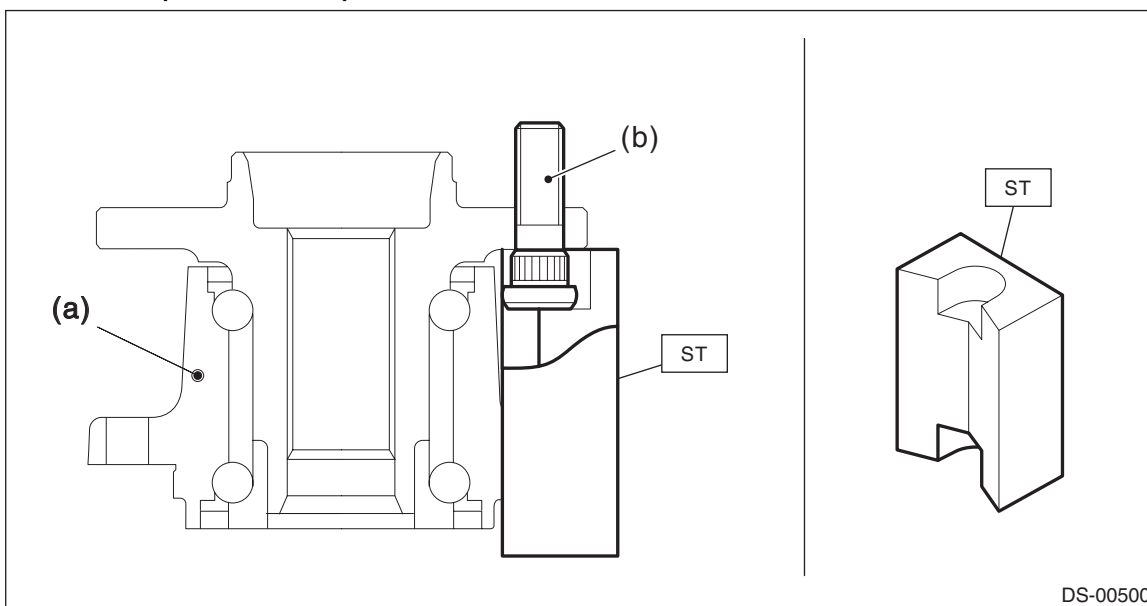

**NOTE:**

Since the hub unit bearing can not be disassembled, only hub bolts can be removed.

# Rear Hub Unit Bearing

DRIVE SHAFT SYSTEM

## D: ASSEMBLY

1) Install the hub unit bearing to the ST securely.

### PREPARATION TOOL:

**ST: HUB STAND (927080000)**

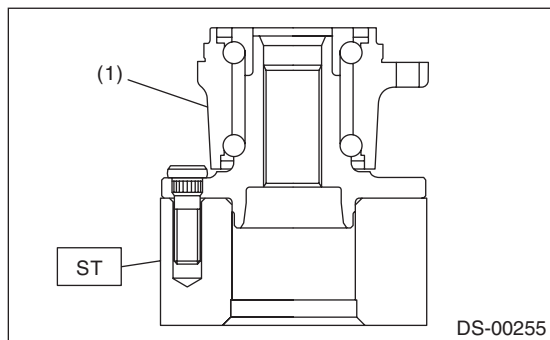

(1) Rear hub unit bearing

2) Using a press, press the new hub bolts (b) until their seating surfaces contact the hub unit bearing (a).

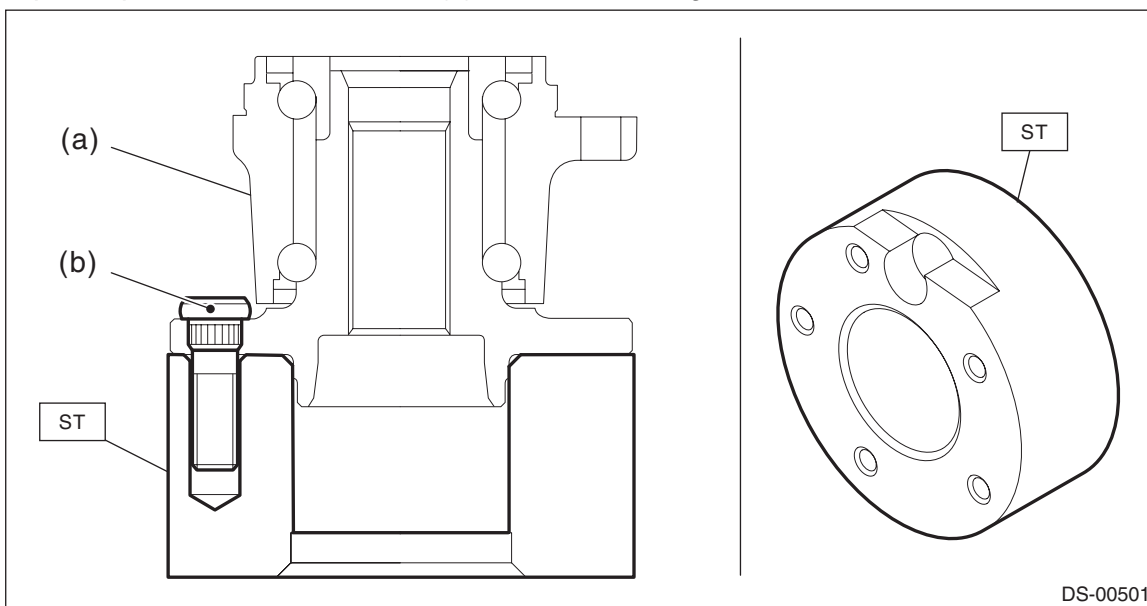

### NOTE:

Use the 12 mm (0.47 in) dia. holes in the HUB STAND to prevent bolts from tilting.



## E: INSPECTION

1) Moving the rear tire up and down by hand, check there is no backlash in bearing, and check the wheel rotates smoothly.

### CAUTION:

If there is any fault in the bearing, replace hub unit bearing.

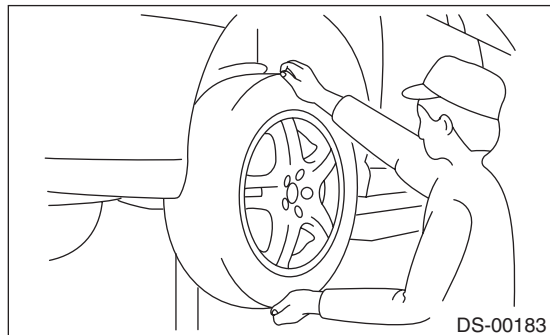

2) Inspect the lean of axis direction using a dial gauge. Replace the bearing if the load range exceeds the limitation.

### Service limit:

**Maximum: 0.05 mm (0.0020 in)**

