

4. Front Stabilizer

A: REMOVAL

- 1) Lift up the vehicle, and then remove the left and right front wheels.
- 2) Remove the front under cover. <Ref. to EI-33, REMOVAL, Front Under Cover.>
- 3) Remove the front stabilizer.
 - (1) Remove the left and right stabilizer links.

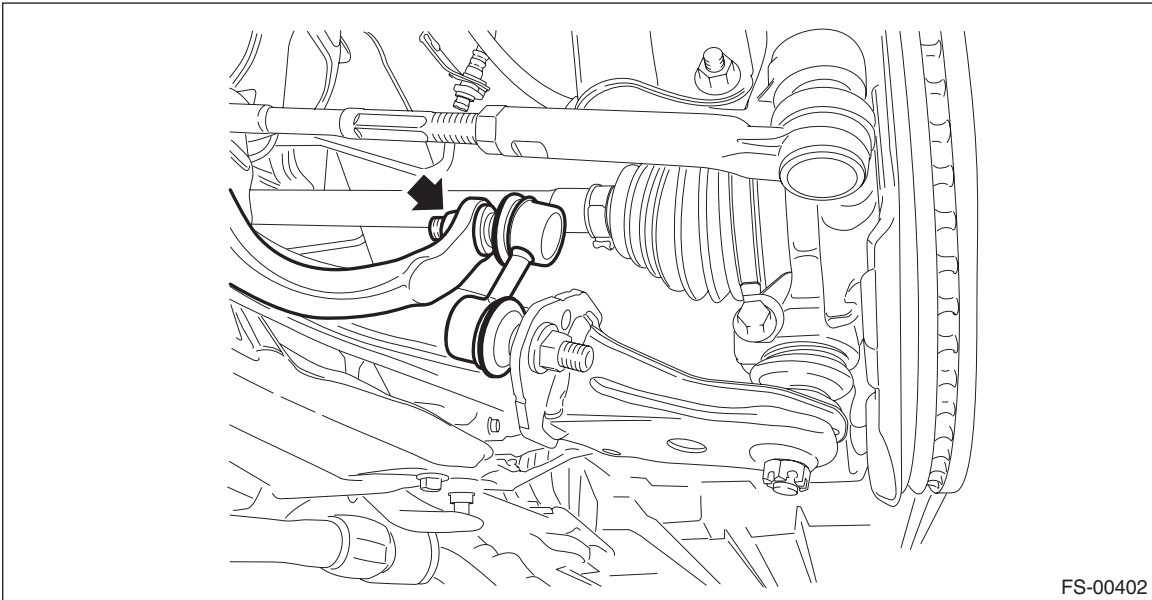

- (2) Remove the left and right stabilizer brackets.

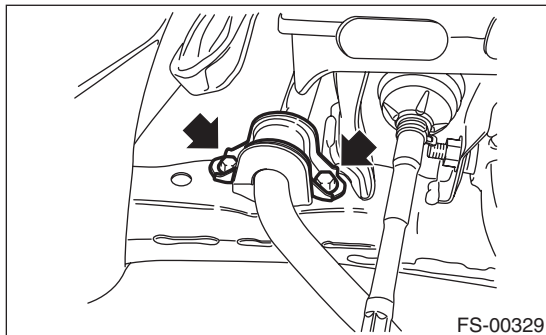

Front Stabilizer

FRONT SUSPENSION

- (3) Disconnect the left and right tie-rod ends.
 - a) Pull out the cotter pin (a).
 - b) Remove the castle nut (b).
 - c) Extract the tie-rod end (c) from the front axle housing.

CAUTION:

Be careful not to damage the boot during removal.

Preparation tool:

Tie-rod ball joint puller

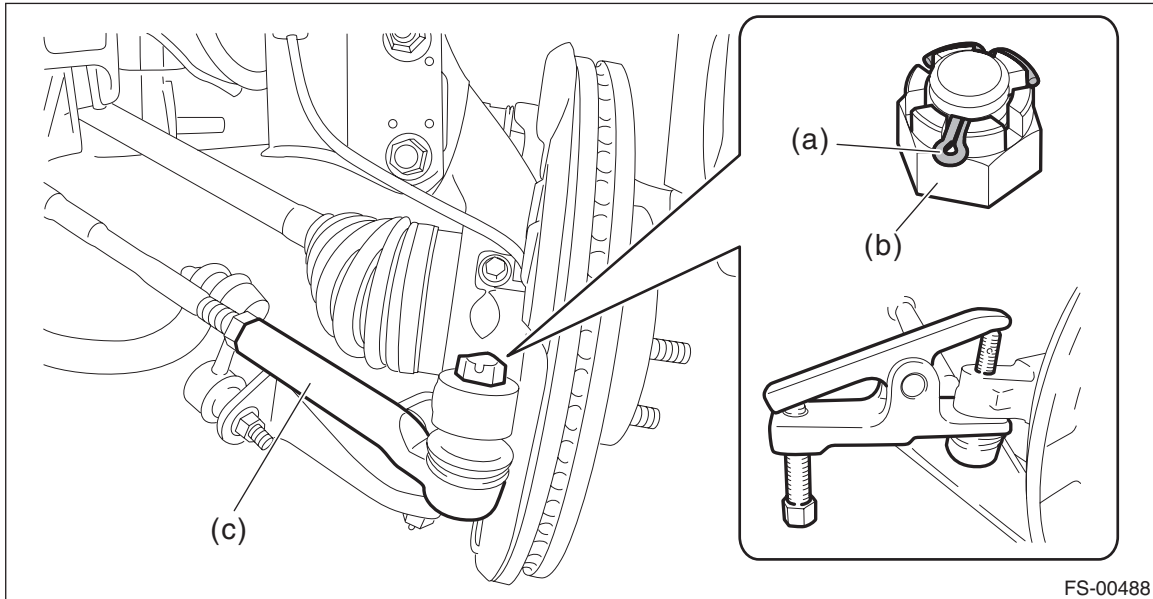

- (4) Turn the front stabilizer by approximately 180° toward the front of the vehicle and pull out the front stabilizer from the right side of the vehicle.

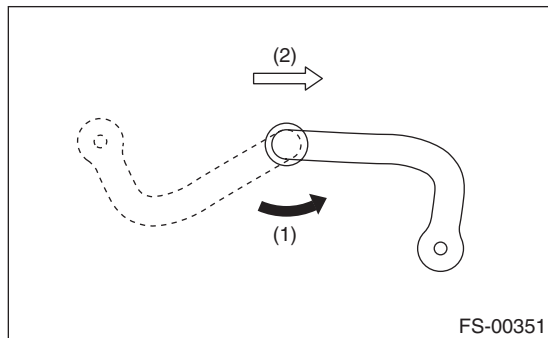

- (1) Turn toward the front of the vehicle.
- (2) Front side of vehicle

B: INSTALLATION

1) Before installation, inspect the following items and replace any faulty part with a new one.

- Check the bushing for abnormal cracks, fatigue or damage.
- Check the stabilizer link for damage.

2) Install each part in the reverse order of removal.

CAUTION:

The stabilizer bracket has a set orientation. Install it with the arrow mark facing the front side (1) of the vehicle.

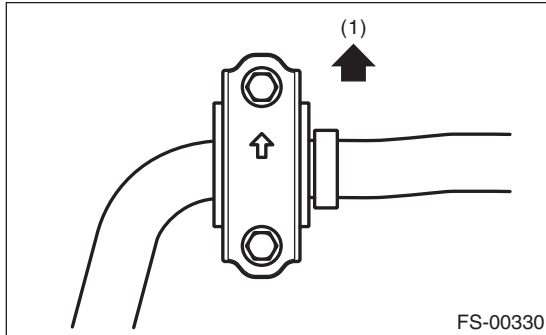

Tightening torque:

Stabilizer bracket: 25 N·m (2.55 kgf-m, 18.4 ft-lb)

Stabilizer link: 60 N·m (6.12 kgf-m, 44.3 ft-lb)

Front wheel: 120 N·m (12.24 kgf-m, 88.5 ft-lb)