

5. Control Module I/O Signal

A: ELECTRICAL SPECIFICATION

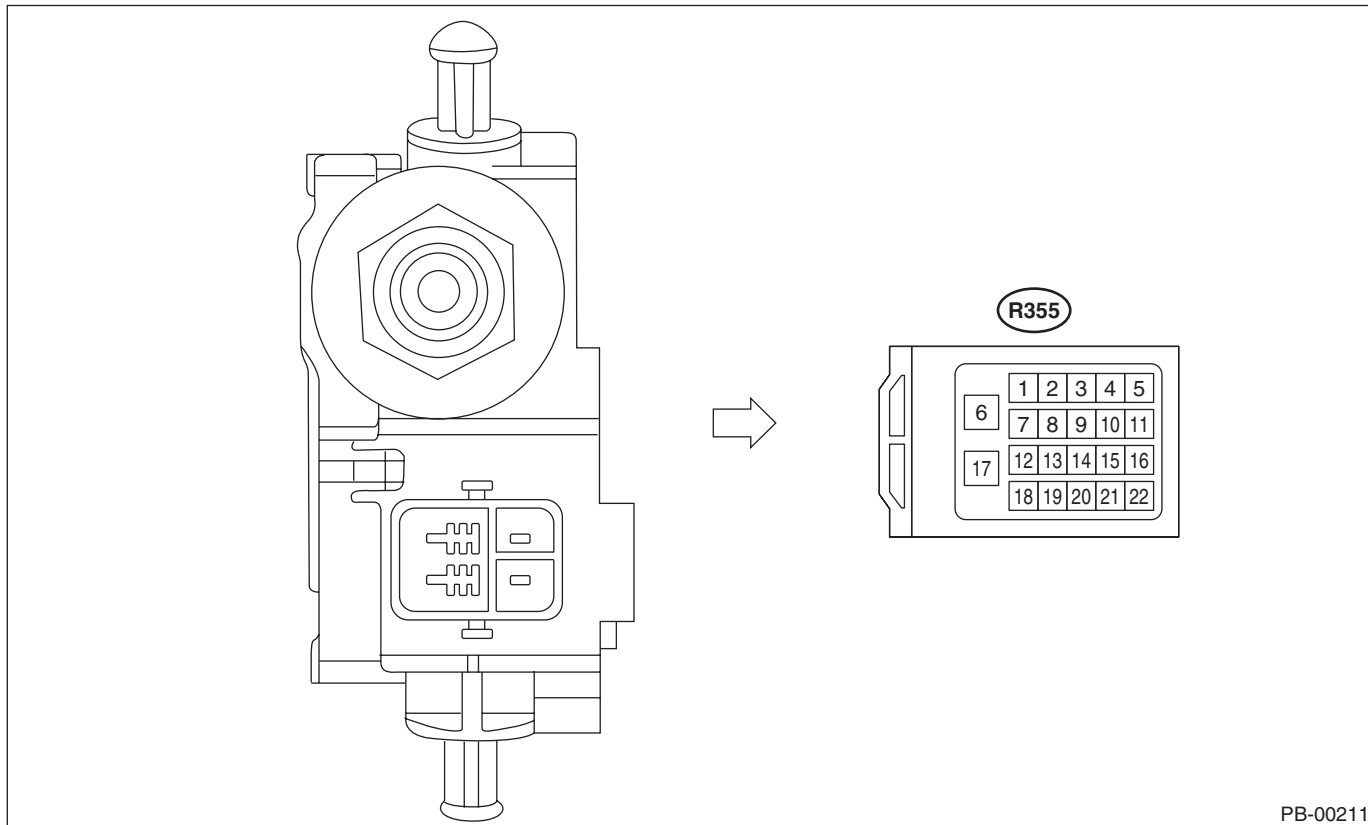

PB-00211

NOTE:

The terminal numbers of the electronic parking brake control module connectors are as indicated in the figure.

Content	Terminal No. (+) — (-)	Input/Output signal
		Measured value and measuring conditions
Battery power supply	17 — 6	Always 10 — 15 V
IGN power supply	18 — 6	10 — 15 V when the ignition switch is ON.
Parking brake switch	13	Pulse signal
Parking brake switch	14	Pulse signal
Parking brake switch	20	Pulse signal
Parking brake switch	19	Pulse signal
Hill hold switch	2 — 6	When hill hold switch is operated, 10 — 15 V
Parking brake switch indicator light	7 — 6	When the light is on: 0 V, when the light is off: 10 — 15 V
Clutch stroke sensor (MT model only)	12	Pulse signal
CAN-H	9	Serial communication
CAN-L	3	Serial communication
Ground	6	—

Control Module I/O Signal

PARKING BRAKE (DIAGNOSTICS)

B: WIRING DIAGRAM

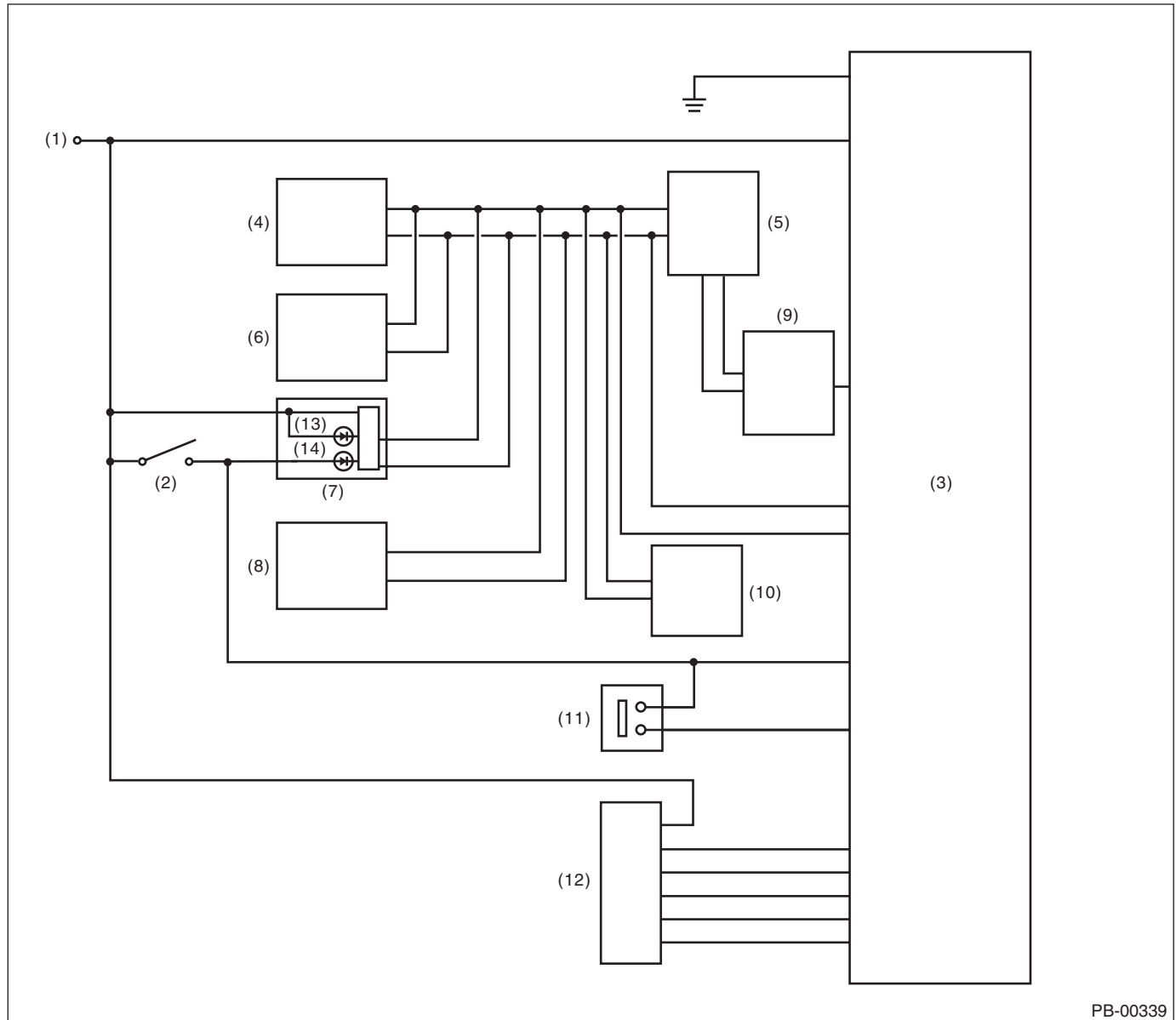

PB-00339

- | | | |
|---------------------------------|--|--------------------------------|
| (1) Battery | (6) Transmission control module | (11) Hill hold switch |
| (2) Ignition switch | (7) Combination meter | (12) Parking brake switch |
| (3) Electronic parking brake CM | (8) Body integrated unit | (13) Hill hold indicator light |
| (4) Engine control module (ECM) | (9) Clutch stroke sensor (MT model only) | (14) Brake warning light |
| (5) VDC control module | (10) Stereo camera (models with EyeSight only) | |