

General Description

REAR SUSPENSION

1. General Description

A: SPECIFICATION

Refer to "SPECIFICATIONS" in "FRONT SUSPENSION" section for rear suspension specifications. <Ref. to FS-2, SPECIFICATION, General Description.>

NOTE:

- Front toe-in, rear toe-in and front camber can be adjusted. Adjust if the value of toe-in or camber exceeds the tolerance range of the specification chart.
- Other items except for front toe-in, rear toe-in and front camber that are described in the specification chart cannot be adjusted. If other items exceed the tolerance range of the specification chart, check the suspension parts and connections for deformation. If defective, replace with new parts.

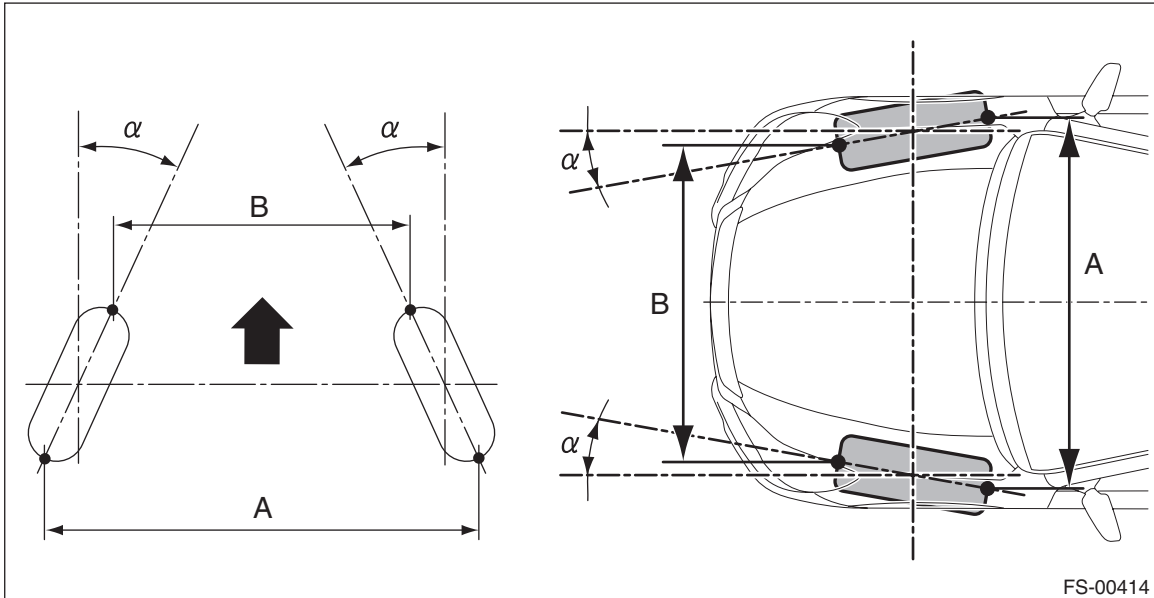

$A - B = \text{Positive: Toe-in, Negative: Toe-out}$

$\alpha = \text{Individual toe angles}$

B: COMPONENT

1. REAR SUSPENSION

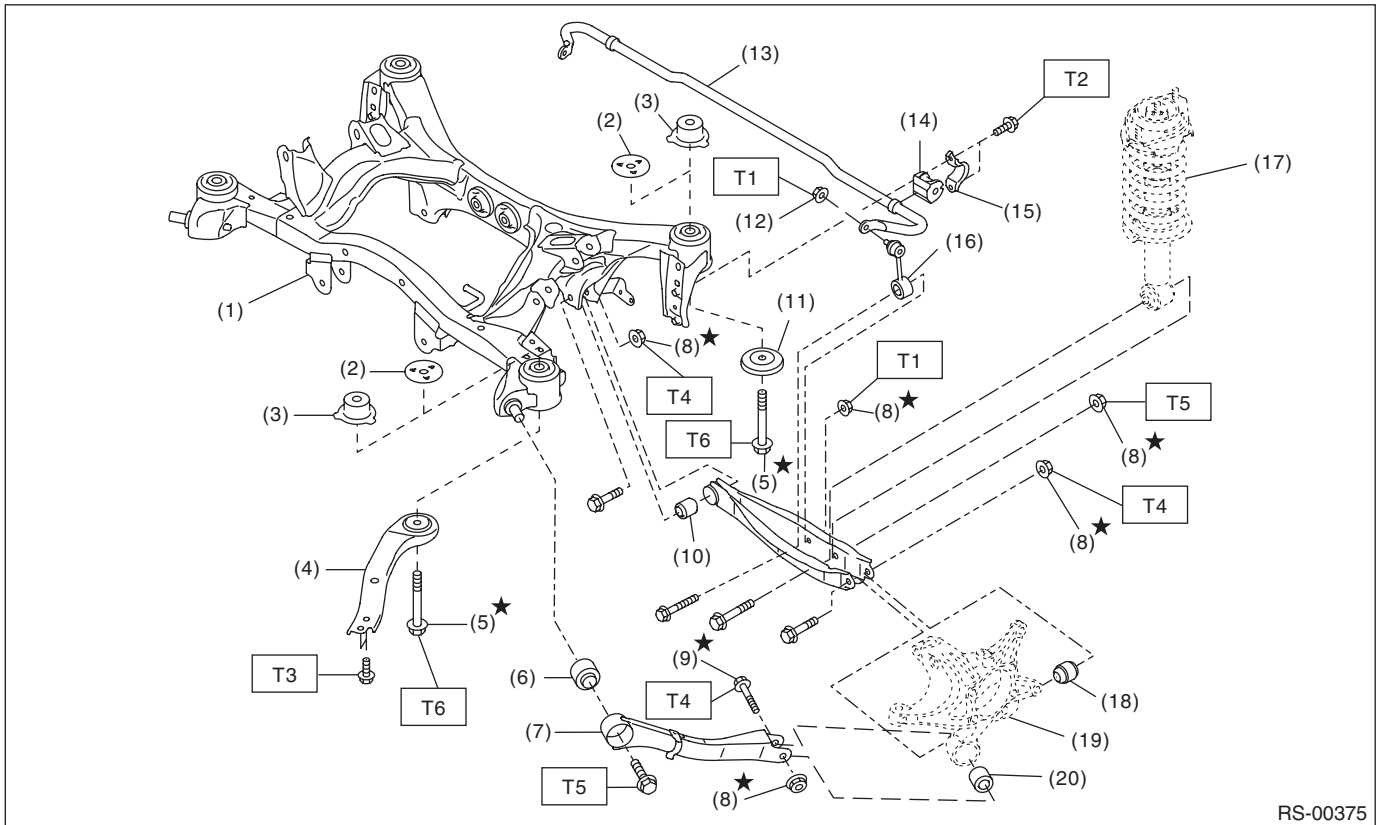

RS-00375

- | | |
|---|-----------------------------------|
| (1) Rear sub frame ASSY | (11) Rear sub frame stopper lower |
| (2) Rear sub frame stopper upper (except for OUTBACK model) | (12) Flange nut |
| (3) Rear sub frame stopper upper (OUTBACK model) | (13) Rear stabilizer |
| (4) Front sub frame support plate | (14) Stabilizer bushing |
| (5) Flange bolt A | (15) Stabilizer clamp |
| (6) Trailing link bushing | (16) Stabilizer link |
| (7) Trailing link | (17) Rear shock absorber ASSY |
| (8) Self-locking nut | (18) Rear axle housing bushing |
| (9) Flange bolt B | (19) Rear axle housing |
| (10) Rear lateral link bushing | (20) Trailing link rear bushing |

Tightening torque: N·m (kgf·m, ft·lb)

T1: 33 (3.36, 24.3)

T2: 38 (3.87, 28.0)

T3: 70 (7.14, 51.6)

T4: 80 (8.16, 59.0)

T5: 120 (12.24, 88.5)

T6: 145 (14.79, 106.9)

General Description

REAR SUSPENSION

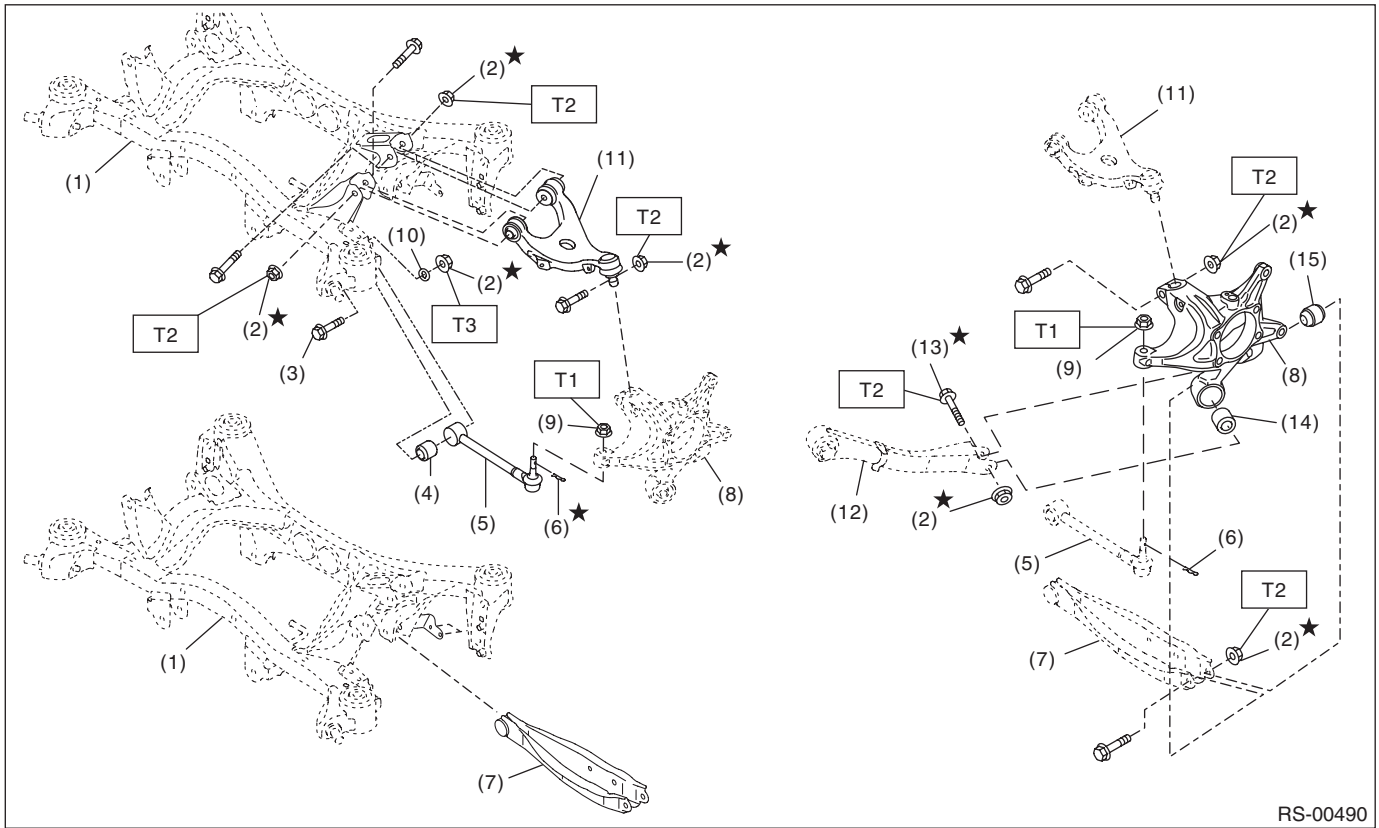

RS-00490

- | | |
|--------------------------------|--------------------------------|
| (1) Rear sub frame ASSY | (9) Flange nut |
| (2) Self-locking nut | (10) Adjusting washer |
| (3) Adjusting bolt | (11) Upper arm |
| (4) Front lateral link bushing | (12) Trailing link |
| (5) Front lateral link | (13) Flange bolt |
| (6) Snap pin | (14) Trailing link bushing |
| (7) Rear lateral link | (15) Rear axle housing bushing |
| (8) Rear axle housing | |

Tightening torque: N-m (kgf-m, ft-lb)

T1: 60 (6.12, 44.3)

T2: 80 (8.16, 59.0)

T3: 120 (12.24, 88.5)

2. REAR STRUT

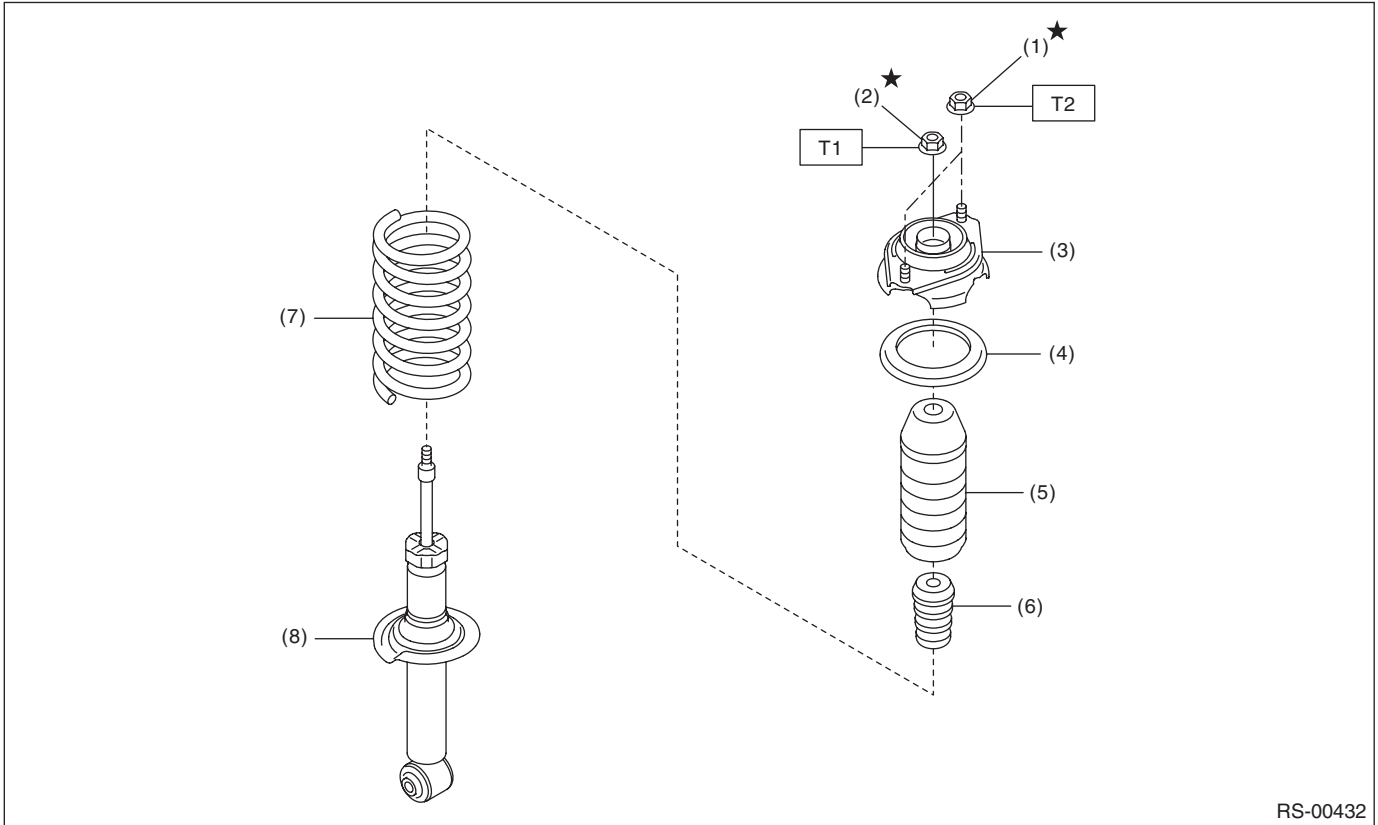

RS-00432

- | | |
|------------------------|--------------------|
| (1) Self-locking nut | (5) Dust cover |
| (2) Self-locking nut | (6) Helper |
| (3) Mount | (7) Coil spring |
| (4) Upper rubber sheet | (8) Shock absorber |

Tightening torque: N·m (kgf·m, ft·lb)

T1: 25 (2.55, 18.4)

T2: 30 (3.06, 22.1)

General Description

REAR SUSPENSION

C: CAUTION

Please clearly understand and adhere to the following general precautions. They must be strictly followed to avoid minor or serious injury to the person doing the work or people in the area.

1. EACH PROCEDURE

- Wear appropriate work clothing, including a helmet, protective goggles and protective shoes when performing any work.
- Before disposing of shock absorbers, be sure to bleed the gas out completely. Also, do not expose to flames or fire.
- Before removal, installation or disassembly, be sure to clarify the failure. Avoid unnecessary removal, installation, disassembly and replacement.
- Use SUBARU genuine grease etc. or equivalent. Do not mix grease etc. of different grades or manufacturers.
- Before securing a part on a vise, place cushioning material such as wood blocks, aluminum plate, or cloth between the part and the vise.
- Be sure to tighten fasteners including bolts and nuts to the specified torque.
- Place shop jacks or rigid racks at the specified points.
- When the suspension-related components have been replaced, perform the adjustment of the steering angle sensor. <Ref. to VDC-20, ADJUSTMENT, VDC Control Module and Hydraulic Control Unit (VDCCM&H/U).>

2. OIL

When handling oil, adhere to the following to prevent unexpected accident.

- Prepare container and waste cloths when performing work which oil could possibly spill. If oil spills, wipe it off immediately to prevent from penetrating into floor or flowing outside, for environmental protection.
- Follow all government regulations concerning disposal of refuse when disposing.

D: PREPARATION TOOL

1. SPECIAL TOOL

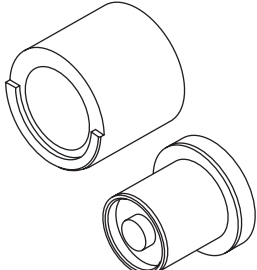
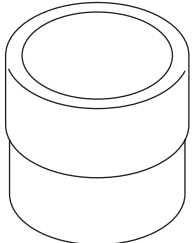
ILLUSTRATION	TOOL NUMBER	DESCRIPTION	REMARKS
 ST20099AE000	20099AE000	INSTALLER & REMOVER	Used for replacing the front lateral link bushing.
 ST-499755602	499755602	PRESS	Used for replacing the rear trailing link bushing.

General Description

REAR SUSPENSION

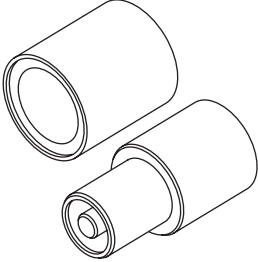
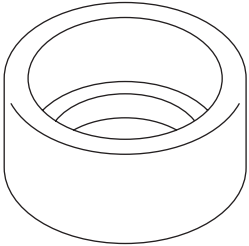
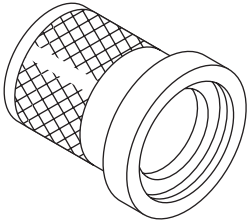
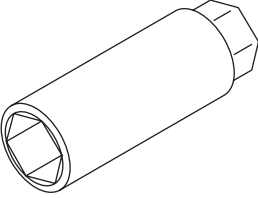
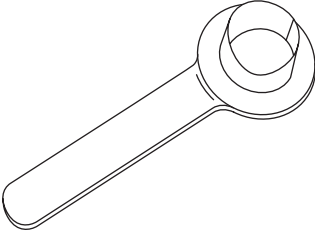
ILLUSTRATION	TOOL NUMBER	DESCRIPTION	REMARKS
 <p>ST20099AE010</p>	20099AE010	INSTALLER & REMOVER	Used for replacing the rear lateral link bushing.
 <p>ST20299AG010</p>	20299AG010	BASE	Used for replacing the rear trailing link bushing.
 <p>ST-899874100</p>	899874100	INSTALLER	Used for replacing the rear trailing link bushing.
 <p>ST20399FG000</p>	20399FG000	STRUT MOUNT SOCKET	<ul style="list-style-type: none"> • Used for removing and installing shock mount. • Used for checking torque of shock mount center nut.
 <p>ST28099PA090</p>	28099PA090	OIL SEAL PROTECTOR	<ul style="list-style-type: none"> • Used for installing the rear drive shaft to the rear differential. • For oil seal protection

General Description

REAR SUSPENSION

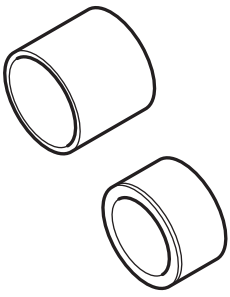
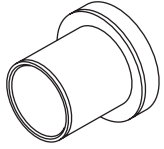
ILLUSTRATION	TOOL NUMBER	DESCRIPTION	REMARKS
 <p style="text-align: center;">ST20099PA010</p>	20099PA010	INSTALLER & REMOVER	<ul style="list-style-type: none"> • Used for replacing the bushing of the rear housing. • Used together with BUSHING REMOVER (20099FG000).
 <p style="text-align: center;">ST20099FG000</p>	20099FG000	BUSHING REMOVER	<ul style="list-style-type: none"> • Used for replacing the bushing of the rear housing. • Used together with base part of INSTALLER & REMOVER (20099PA010).

2. GENERAL TOOL

TOOL NAME	REMARKS
Alignment tester	Used for measuring wheel alignment.
Toe-in gauge	Used for toe-in measurement.
Jack	Used for removing and installing suspension.
Bearing puller	Used for removing bushings.
Tie-rod ball joint puller	Used for disconnecting the lateral link assembly - front.
Coil spring compressor	Used for disassembling and assembling shock absorber.