

Rear Lateral Link

REAR SUSPENSION

9. Rear Lateral Link

A: REMOVAL

- 1) Disconnect the ground cable from battery.
- 2) Lift up the vehicle, and then remove the rear wheels.
- 3) Remove the bolts and nuts and lower the rear lateral link.
 - (1) Remove the nut and disconnect the rear stabilizer link.
 - (2) Remove the shock absorber lower bolt.
 - (3) Disconnect the rear lateral link.

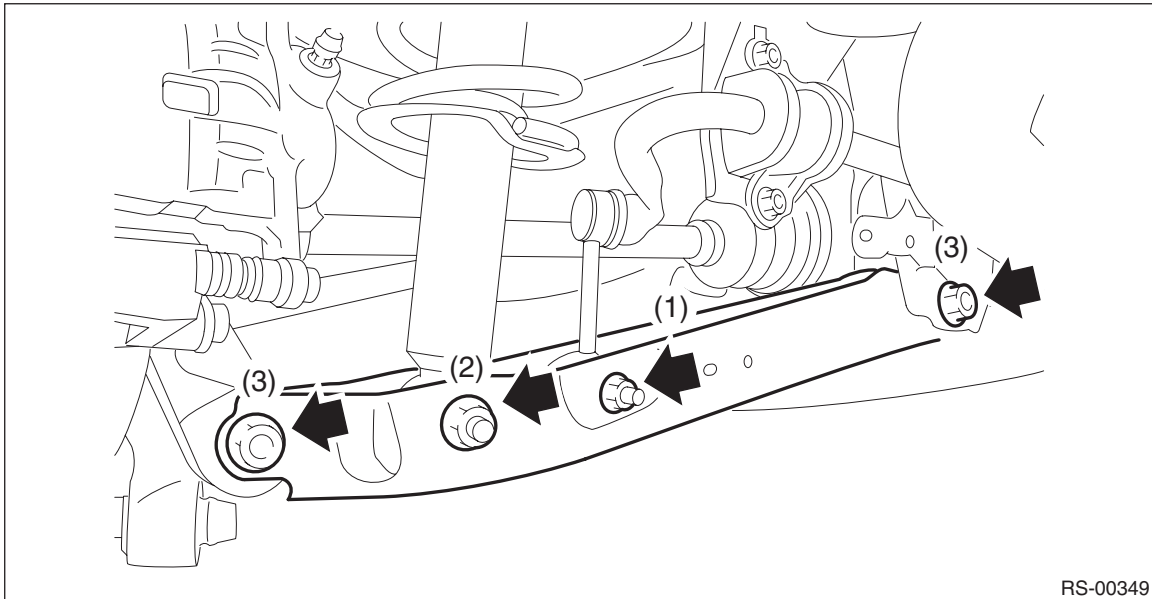

RS-00349

B: INSTALLATION

CAUTION:

- Be sure to use a new self-locking nut.
- Always tighten the bushing in the state where the vehicle is at curb weight and the wheels are in full contact with the ground.

- 1) Before installation, inspect the following items and replace any faulty part with a new one.
 - Visually check the rear lateral link for damage and deformation.
 - Visually check the bushing for abnormal cracks, fatigue or damage.
- 2) Install each part in the reverse order of removal.

Tightening torque:

Rear lateral link: 80 N·m (8.16 kgf-m, 59.0 ft-lb)

Shock absorber: 120 N·m (12.24 kgf-m, 88.5 ft-lb)

Stabilizer link: 33 N·m (3.36 kgf-m, 24.3 ft-lb)

Rear wheel: 120 N·m (12.24 kgf-m, 88.5 ft-lb)

- 3) Inspect the wheel alignment and adjust if necessary. <Ref. to FS-9, INSPECTION, Wheel Alignment.>

CAUTION:

When the wheel alignment has been adjusted, perform the 0 point setting mode for each sensor in the VDCCM&H/U. <Ref. to VDC-20, ADJUSTMENT, VDC Control Module and Hydraulic Control Unit (VDCCM&H/U).>

C: DISASSEMBLY

Using the ST, push out the bushing.

PREPARATION TOOL:

ST-A & ST-B: INSTALLER & REMOVER (20299AE010)

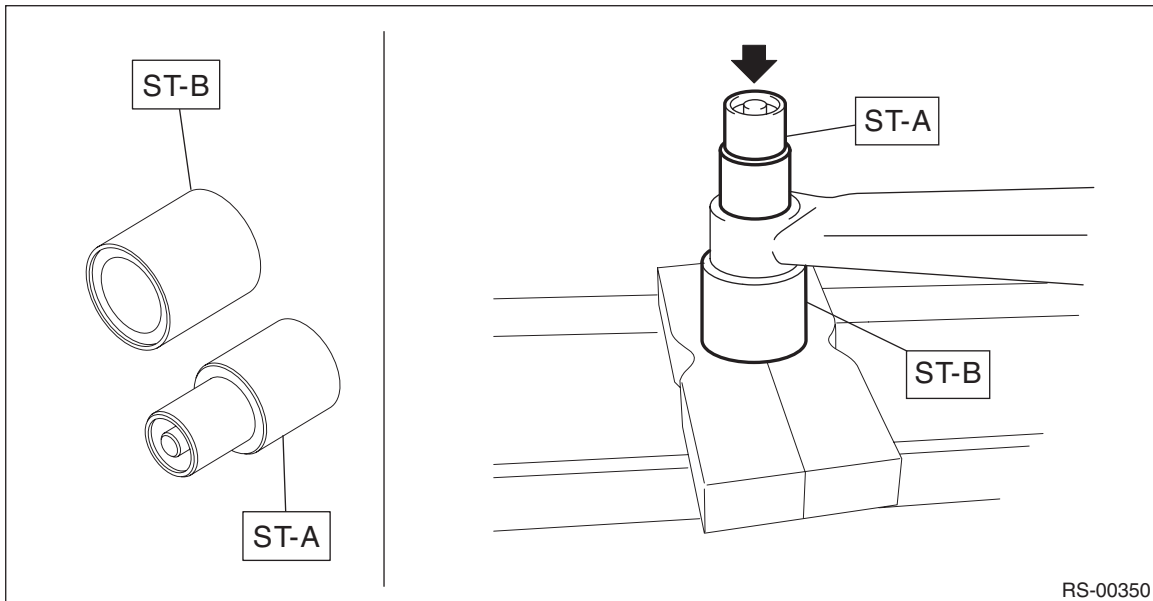
**D: ASSEMBLY**

1) Before assembly, inspect the following items and replace any faulty part with a new one.

- Visually check the rear lateral link for damage and deformation.
- Visually check the bushing for abnormal cracks, fatigue or damage.

2) Using the ST, press the bushing into place.

PREPARATION TOOL:

ST-A & ST-B: INSTALLER & REMOVER (20299AE010)

