

Warning Light Illumination Pattern

VEHICLE DYNAMICS CONTROL (VDC) (DIAGNOSTICS)

10.Warning Light Illumination Pattern

A: INSPECTION

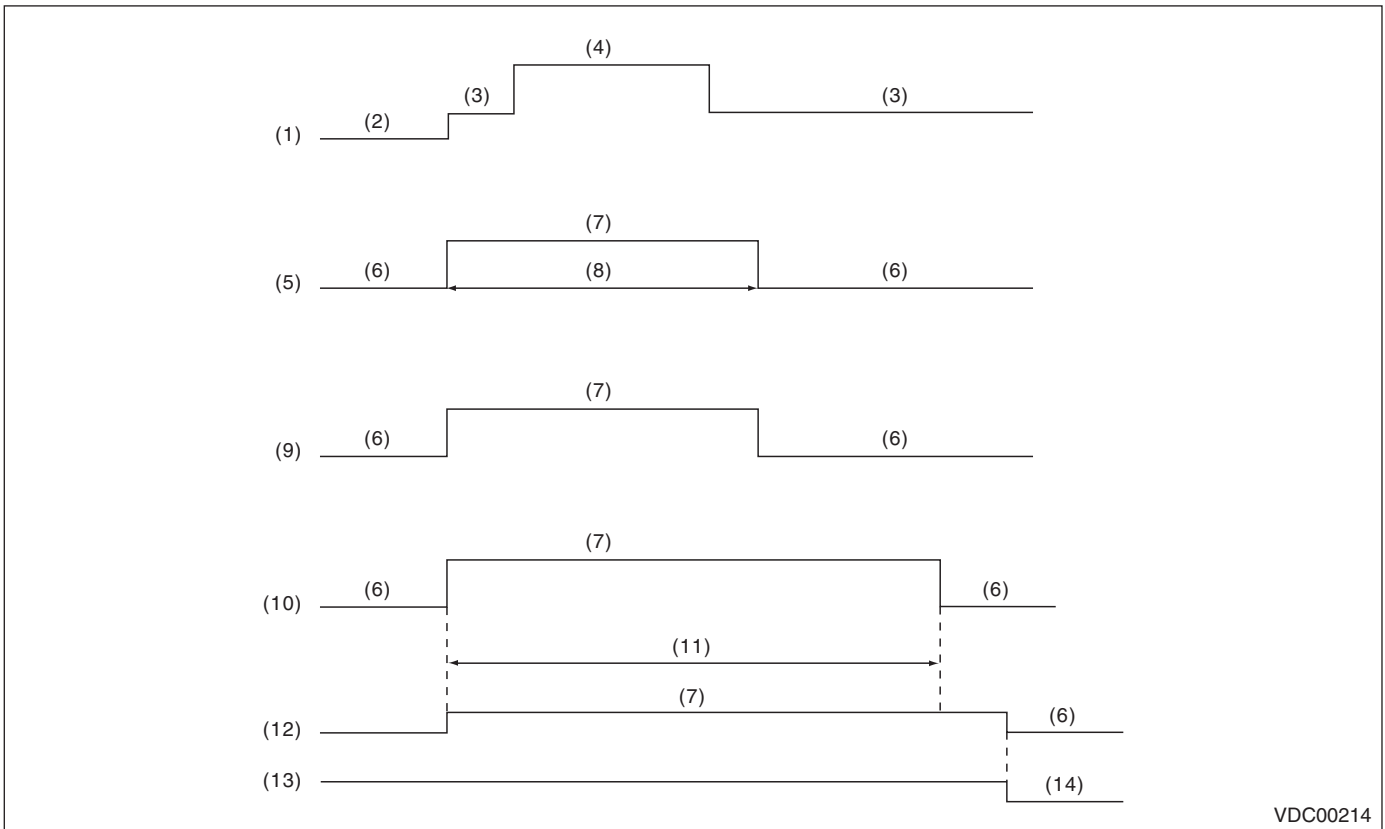

VDC00214

- | | | |
|-----------------------|--|--|
| (1) Ignition switch | (6) Light OFF | (11) Several seconds (depending on engine coolant temperature) |
| (2) OFF | (7) Light ON | (12) Brake warning light (EBD warning light) |
| (3) ON | (8) 2 seconds | (13) Parking brake |
| (4) Engine start | (9) VDC OFF indicator light | (14) Released |
| (5) ABS warning light | (10) VDC warning light & VDC indicator light | |

Warning Light Illumination Pattern

VEHICLE DYNAMICS CONTROL (VDC) (DIAGNOSTICS)

1) When warning lights or indicator lights do not illuminate in accordance with this illumination pattern, there must be an electrical malfunction.

2) When warning lights or indicator lights remain constantly OFF, check the combination meter circuit or CAN communication circuit. <Ref. to VDC(diag)-28, ABS WARNING LIGHT, VDC OFF INDICATOR LIGHT, VDC WARNING LIGHT AND VDC INDICATOR LIGHT DO NOT COME ON, Warning Light Illumination Pattern.>

3) When the ABS warning light, VDC OFF indicator light, and VDC warning light & VDC indicator light do not go off, check the combination meter circuit or CAN communication circuit. <Ref. to VDC(diag)-29, ABS WARNING LIGHT DOES NOT GO OFF, Warning Light Illumination Pattern.> <Ref. to VDC(diag)-31, VDC OFF INDICATOR LIGHT DOES NOT GO OFF, Warning Light Illumination Pattern.> <Ref. to VDC(diag)-30, VDC WARNING LIGHT AND VDC INDICATOR LIGHT DO NOT GO OFF, Warning Light Illumination Pattern.>

4) When the brake warning light blinks and the hill hold indicator light illumination is faulty, check the parking brake system. <Ref. to PB(diag)-2, Basic Diagnostic Procedure.>

NOTE:

- Even though the ABS warning light, and the VDC warning light & VDC indicator light do not go off in 2 seconds after illuminating, the ABS and VDC functions are normal if the warning lights go off while the vehicle is driven at approximately 12 km/h (7 MPH). However, while these lights are on, the functions with their warning lights illuminated do not operate.
- It may take several minutes before the VDC warning light & VDC indicator light goes off, if the vehicle is parked under low temperature for a specified time. This is not defective because it is resulted from low engine coolant temperature. If DTC is recorded at this time, perform the Clear Memory Mode. <Ref. to VDC(diag)-25, Clear Memory Mode.>
- With the vehicle jack-up/lift-up or set on free rollers, when the wheels lock or spin after starting the engine, ABS warning light, and VDC warning light & VDC indicator light may illuminate because VDC-CM&H/U detects the abnormal conditions from ABS wheel speed sensors. In this case, this is not a malfunction. Perform the Clear Memory Mode. <Ref. to VDC(diag)-25, Clear Memory Mode.>
- On models with EyeSight, turn the pre-collision function to OFF.

Warning Light Illumination Pattern

VEHICLE DYNAMICS CONTROL (VDC) (DIAGNOSTICS)

B: ABS WARNING LIGHT, VDC OFF INDICATOR LIGHT, VDC WARNING LIGHT AND VDC INDICATOR LIGHT DO NOT COME ON

DETECTING CONDITION:

- Defective combination meter
- Defective CAN communication

TROUBLE SYMPTOM:

When the ignition switch is turned to ON (engine OFF), ABS warning light, VDC OFF indicator light, and VDC warning light & VDC indicator light do not illuminate.

NOTE:

When pressing the VDC OFF switch for 10 seconds or more, the VDC OFF indicator light goes off and cannot operate any more. When turning the ignition switch from OFF to ON, the OFF operation enabled status is restored.

Step	Check	Yes	No
1 CHECK OTHER INDICATOR LIGHT. Turn the ignition switch to ON.	Does other indicator light illuminate soon after "ON"?	Go to step 2.	Perform the self-diagnosis of combination meter. <Ref. to IDI-8, SELF-DIAGNOSIS DISPLAY MODE, OPERATION, Combination Meter System.>
2 CHECK LAN SYSTEM. Perform the diagnosis for LAN system. <Ref. to LAN(diag)-2, Basic Diagnostic Procedure.>	Is there any fault in LAN system?	Perform the diagnosis according to DTC for LAN system. <Ref. to LAN(diag)-54, List of Diagnostic Trouble Code (DTC).>	Go to step 3.
3 CHECK VDCCM. When the engine does not start, display the current data of VDCCM using Subaru Select Monitor.	Is the «EBD Warning Light» output ON?	Go to step 4.	Replace the VDCCM&H/U. <Ref. to VDC-10, VDC Control Module and Hydraulic Control Unit (VDCCM&H/U).>
4 CHECK VDCCM. When the engine does not start, display the current data of VDCCM using Subaru Select Monitor.	Is the «ABS Warning Light» output ON?	Go to step 5.	Replace the VDCCM&H/U. <Ref. to VDC-10, VDC Control Module and Hydraulic Control Unit (VDCCM&H/U).>
5 CHECK VDCCM. When the engine does not start, display the current data of VDCCM using Subaru Select Monitor.	Is the «VDC Warning Light» output ON?	Go to step 6.	Replace the VDCCM&H/U. <Ref. to VDC-10, VDC Control Module and Hydraulic Control Unit (VDCCM&H/U).>
6 CHECK COMBINATION METER. Check the combination meter. <Ref. to IDI-8, SELF-DIAGNOSIS DISPLAY MODE, OPERATION, Combination Meter System.>	Is combination meter OK?	Replace the VDCCM&H/U. <Ref. to VDC-10, VDC Control Module and Hydraulic Control Unit (VDCCM&H/U).>	Replace the combination meter. <Ref. to IDI-25, Combination Meter.>

Warning Light Illumination Pattern

VEHICLE DYNAMICS CONTROL (VDC) (DIAGNOSTICS)

C: ABS WARNING LIGHT DOES NOT GO OFF

DETECTING CONDITION:

- Defective combination meter
- Defective CAN communication

TROUBLE SYMPTOM:

When starting the engine, the ABS warning light is kept ON.

Step	Check	Yes	No
1 READ DTC. Read the DTC. <Ref. to VDC(diag)-23, Read Diagnostic Trouble Code (DTC).>	Is DTC displayed?	Perform the diagnosis according to DTC. <Ref. to VDC(diag)-35, List of Diagnostic Trouble Code (DTC).>	Go to step 2.
2 CHECK LAN SYSTEM. Perform the diagnosis for LAN system. <Ref. to LAN(diag)-2, Basic Diagnostic Procedure.>	Is there any fault in LAN system?	Perform the diagnosis according to DTC for LAN system. <Ref. to LAN(diag)-54, List of Diagnostic Trouble Code (DTC).>	Go to step 3.
3 CHECK COMBINATION METER. Check the combination meter. <Ref. to IDI-8, SELF-DIAGNOSIS DISPLAY MODE, OPERATION, Combination Meter System.>	Is combination meter OK?	Replace the VDCCM&H/U. <Ref. to VDC-10, VDC Control Module and Hydraulic Control Unit (VDCCM&H/U).>	Replace the combination meter. <Ref. to IDI-25, Combination Meter.>

Warning Light Illumination Pattern

VEHICLE DYNAMICS CONTROL (VDC) (DIAGNOSTICS)

D: VDC WARNING LIGHT AND VDC INDICATOR LIGHT DO NOT GO OFF

DETECTING CONDITION:

- Defective combination meter
- Defective engine
- Defective CAN communication

TROUBLE SYMPTOM:

When starting the engine, the VDC warning light & VDC indicator light remains lit.

Step	Check	Yes	No
1 READ DTC. Read the DTC. <Ref. to VDC(diag)-23, Read Diagnostic Trouble Code (DTC).>	Is DTC displayed?	Perform the diagnosis according to DTC. <Ref. to VDC(diag)-35, List of Diagnostic Trouble Code (DTC).>	Go to step 2.
2 CHECK ENGINE.	Does the malfunction indicator light illuminate?	Repair the engine. <Ref. to EN(H4DO)(diag)-45, Read Diagnostic Trouble Code (DTC).> <Ref. to EN(H6DO)(diag)-48, Read Diagnostic Trouble Code (DTC).>	Go to step 3.
3 CHECK ENGINE COOLANT TEMPERATURE. Warm up the engine, and check if the VDC warning light & VDC indicator light illumination condition changes.	When the engine coolant temperature is too low, the VDC warning light & VDC indicator light illuminates. Do the lights go off when the engine is warmed up?	Normal If DTC is recorded, clear the memory. <Ref. to VDC(diag)-25, Clear Memory Mode.>	Go to step 4.
4 CHECK LAN SYSTEM. Perform the diagnosis for LAN system. <Ref. to LAN(diag)-2, Basic Diagnostic Procedure.>	Is there any fault in LAN system?	Perform the diagnosis according to DTC for LAN system. <Ref. to LAN(diag)-54, List of Diagnostic Trouble Code (DTC).>	Go to step 5.
5 CHECK COMBINATION METER. Check the combination meter. <Ref. to IDI-8, SELF-DIAGNOSIS DISPLAY MODE, OPERATION, Combination Meter System.>	Is combination meter OK?	Replace the VDCCM&H/U. <Ref. to VDC-10, VDC Control Module and Hydraulic Control Unit (VDCCM&H/U).>	Replace the combination meter. <Ref. to IDI-25, Combination Meter.>

Warning Light Illumination Pattern

VEHICLE DYNAMICS CONTROL (VDC) (DIAGNOSTICS)

E: VDC OFF INDICATOR LIGHT DOES NOT GO OFF

DETECTING CONDITION:

- Defective combination meter
- Defective CAN communication
- VDC OFF switch is shorted.

TROUBLE SYMPTOM:

When starting the engine, VDC OFF indicator light is kept ON.

NOTE:

When pressing the VDC OFF switch for 10 seconds or more, the VDC OFF indicator light goes off and cannot operate any more. When turning the ignition switch from OFF to ON, the OFF operation enabled status is restored.

Step	Check	Yes	No
1 READ DTC. Read the DTC. <Ref. to VDC(diag)-23, Read Diagnostic Trouble Code (DTC).>	Is DTC displayed?	Perform the diagnosis according to DTC. <Ref. to VDC(diag)-35, List of Diagnostic Trouble Code (DTC).>	Go to step 2.
2 CHECK VDC OFF SWITCH. Remove and check VDC OFF switch. <Ref. to VDC-40, VDC OFF Switch.>	Is the VDC OFF switch normal?	Go to step 3.	Replace the VDC OFF switch.
3 CHECK LAN SYSTEM. Perform the diagnosis for LAN system. <Ref. to LAN(diag)-2, Basic Diagnostic Procedure.>	Is there any fault in LAN system?	Perform the diagnosis according to DTC for LAN system. <Ref. to LAN(diag)-54, List of Diagnostic Trouble Code (DTC).>	Go to step 4.
4 CHECK COMBINATION METER. Check the combination meter. <Ref. to IDI-8, SELF-DIAGNOSIS DISPLAY MODE, OPERATION, Combination Meter System.>	Is combination meter OK?	Replace the VDCCM&H/U. <Ref. to VDC-10, VDC Control Module and Hydraulic Control Unit (VDCCM&H/U).>	Replace the combination meter. <Ref. to IDI-25, Combination Meter.>

Warning Light Illumination Pattern

VEHICLE DYNAMICS CONTROL (VDC) (DIAGNOSTICS)

F: BRAKE WARNING LIGHT DOES NOT GO OFF

DETECTING CONDITION:

- Brake warning light circuit is shorted.
- Defective sensor/connector

TROUBLE SYMPTOM:

After starting the engine, the brake warning light remains lit though the parking lever is released.

NOTE:

When brake warning light blinks, check the parking brake system. <Ref. to PB(diag)-2, Basic Diagnostic Procedure.>

Warning Light Illumination Pattern

VEHICLE DYNAMICS CONTROL (VDC) (DIAGNOSTICS)

WIRING DIAGRAM:

Parking brake / brake fluid level warning light system <Ref. to WI-229, Parking Brake / Brake Fluid Level Warning Light System.>

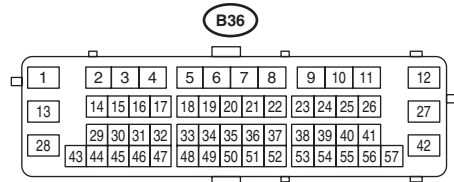
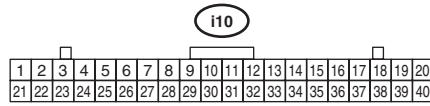
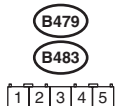
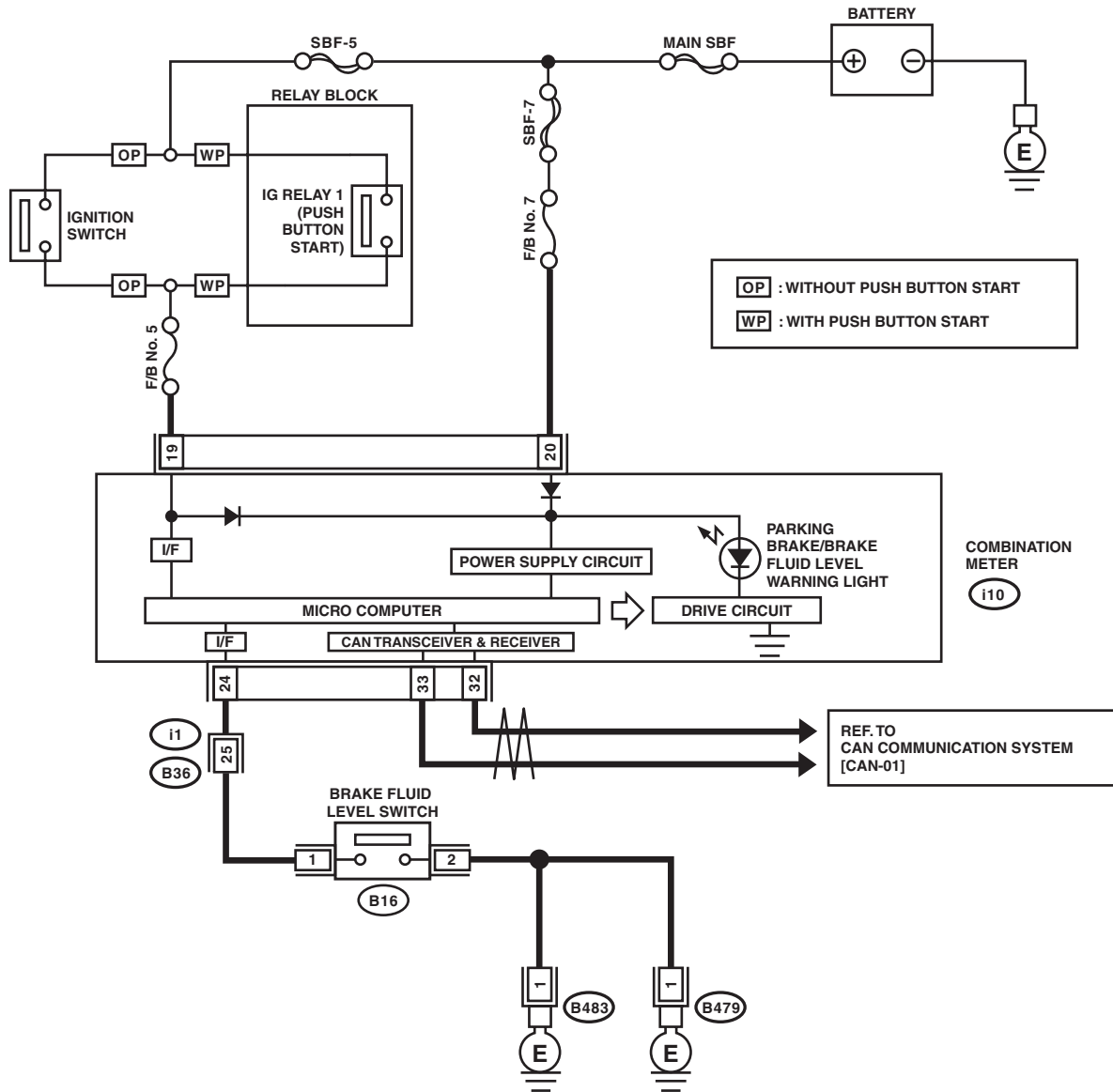

VDC01049

Step	Check	Yes	No
1	CHECK INSTALLATION OF VDCCM&H/U CONNECTOR. 1) Turn the ignition switch to OFF. 2) Check that the VDCCM&H/U connector is inserted until it is locked by clamp.	Go to step 2.	Insert the VDCCM&H/U connector until it is locked by clamp.

Warning Light Illumination Pattern

VEHICLE DYNAMICS CONTROL (VDC) (DIAGNOSTICS)

Step	Check	Yes	No
2 READ DTC. Read the DTC. <Ref. to VDC(diag)-23, Read Diagnostic Trouble Code (DTC).>	Is DTC displayed?	Perform the diagnosis according to DTC. <Ref. to VDC(diag)-35, List of Diagnostic Trouble Code (DTC).>	Go to step 3.
3 CHECK BRAKE FLUID AMOUNT. Check the amount of brake fluid in the reservoir tank of master cylinder.	Does the level of the brake fluid amount fall between the lines of "MAX" and "MIN"?	Go to step 4.	Replenish brake fluid to the specified value.
4 CHECK BRAKE FLUID LEVEL SWITCH. 1) Turn the ignition switch to OFF. 2) Disconnect the level switch connector (B16) from master cylinder. 3) Measure the resistance of master cylinder terminals. Terminals No. 1 — No. 2:	Is the resistance 1 MΩ or more?	Go to step 5.	Replace the master cylinder. <Ref. to BR-39, Master Cylinder.>
5 CHECK GROUND SHORT OF HARNESS. 1) Disconnect the connector from the combination meter. 2) Measure the resistance between combination meter connector and chassis ground. Connector & terminal (i10) No. 24 — Chassis ground:	Is the resistance 1 MΩ or more?	Go to step 6.	Repair the harness connector between combination meter and brake fluid level switch.
6 CHECK LAN SYSTEM. Perform the diagnosis for LAN system. <Ref. to LAN(diag)-2, Basic Diagnostic Procedure.>	Is there any fault in LAN system?	Perform the diagnosis according to DTC for LAN system. <Ref. to LAN(diag)-54, List of Diagnostic Trouble Code (DTC).>	Go to step 7.
7 CHECK COMBINATION METER. Check the combination meter. <Ref. to IDI-8, SELF-DIAGNOSIS DISPLAY MODE, OPERATION, Combination Meter System.>	Is combination meter OK?	Perform the diagnosis for the parking brake system. <Ref. to PB(diag)-21, Read Diagnostic Trouble Code (DTC).>	Replace the combination meter. <Ref. to IDI-25, Combination Meter.>