

VDC Control Module and Hydraulic Control Unit (VDCCM&H/U)

VEHICLE DYNAMICS CONTROL (VDC)

4. VDC Control Module and Hydraulic Control Unit (VDCCM&H/U)

A: REMOVAL

1. MODELS WITHOUT EyeSight

- 1) Disconnect the ground cable from battery.
- 2) Remove the air intake boot.
 - H4 model: <Ref. to IN(H4DO)-13, REMOVAL, Air Intake Boot.>
 - H6 model: <Ref. to IN(H6DO)-7, REMOVAL, Air Intake Boot.>
- 3) Remove the VDC control module & hydraulic control unit (VDCCM&H/U).
 - (1) Remove any dirt from around the VDCCM&H/U.
 - (2) Push the lock button (a), pull down the lock lever (b) and disconnect the VDCCM&H/U connector.

CAUTION:

Do not pull on the harness when disconnecting the connector.

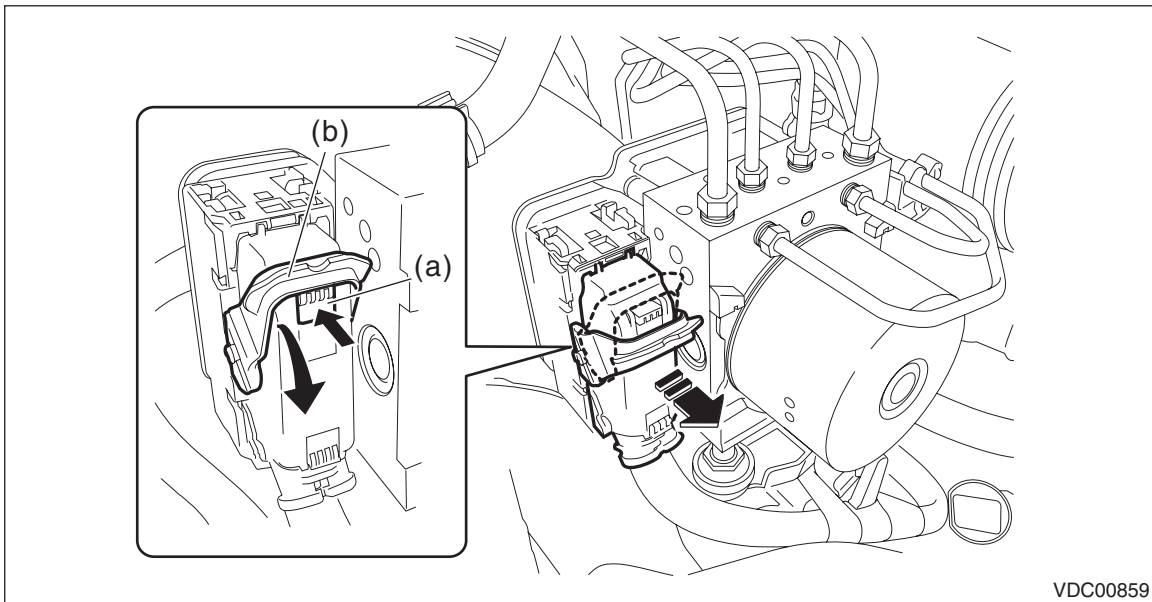

VDC00859

VDC Control Module and Hydraulic Control Unit (VDCCM&H/U)

VEHICLE DYNAMICS CONTROL (VDC)

(3) Using a flare nut wrench, disconnect each brake pipe from VDCCM&H/U.

CAUTION:

- Wrap the brake pipe with a vinyl bag so as not to spill the brake fluid on the painted surface of the vehicle body.
- If brake fluid is spilled on the painted surface of the vehicle body, wash it off immediately with water and wipe clean.

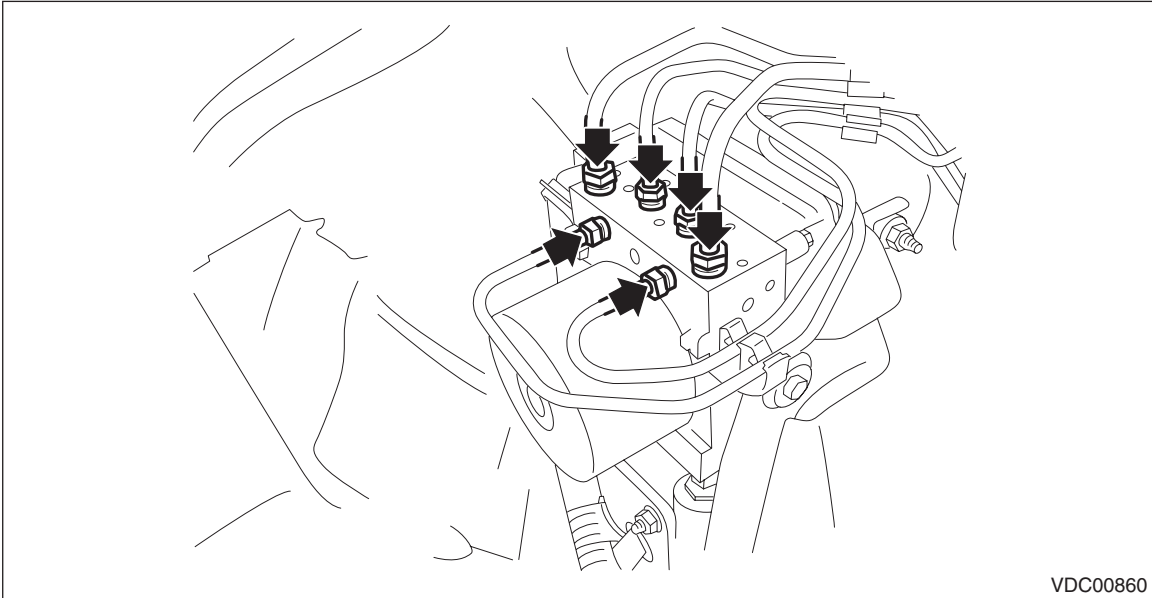

VDC00860

(4) Remove the bolt, and then remove the VDCCM&H/U from the bracket damper.

CAUTION:

- Do not drop or bump the VDCCM&H/U.
- Do not turn the VDCCM&H/U upside down or place it sideways for storage.
- Be careful not to let foreign matter enter the VDCCM&H/U.
- Be careful that no water and fluid enter the connectors.

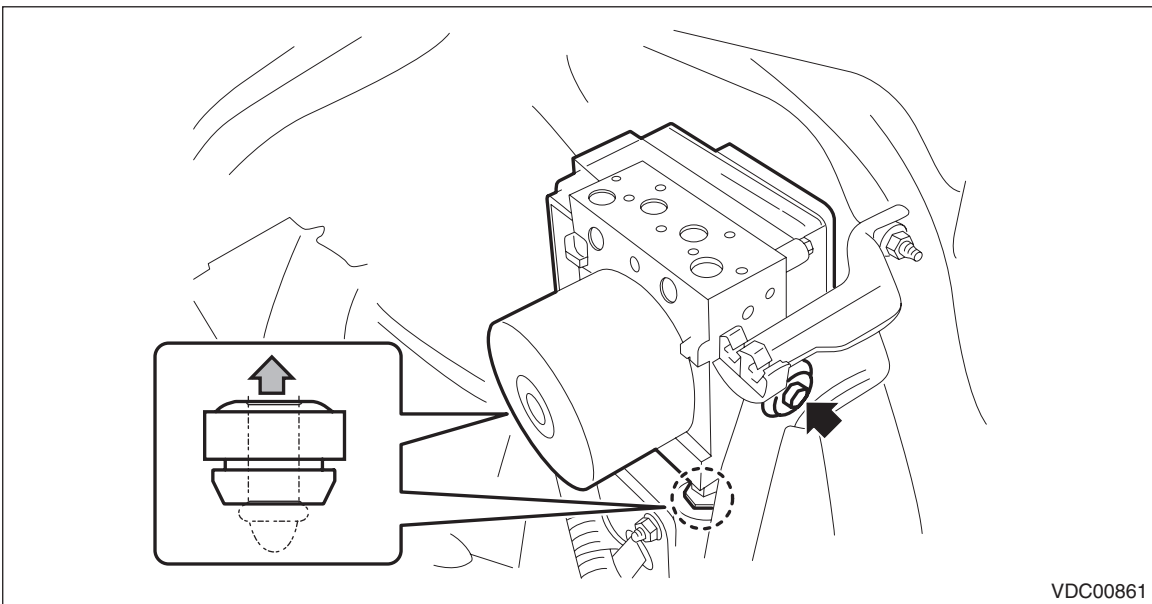

VDC00861

VDC Control Module and Hydraulic Control Unit (VDCCM&H/U)

VEHICLE DYNAMICS CONTROL (VDC)

2. MODELS WITH EyeSight

CAUTION:

- Avoid unnecessary removal of parts in order to prevent fluid leakage.
- When the VDCCM&H/U components are removed, be sure to perform the installation according to the installation procedures. <Ref. to VDC-14, MODELS WITH EyeSight, INSTALLATION, VDC Control Module and Hydraulic Control Unit (VDCCM&H/U).>

1) Disconnect the ground cable from battery.

2) Remove the air intake boot.

• H4 model: <Ref. to IN(H4DO)-13, REMOVAL, Air Intake Boot.>

• H6 model: <Ref. to IN(H6DO)-7, REMOVAL, Air Intake Boot.>

3) Remove the VDC control module & hydraulic control unit (VDCCM&H/U).

(1) Remove any dirt from around the VDCCM&H/U.

(2) Push the lock button (a), pull down the lock lever (b) and disconnect the VDCCM&H/U connector.

CAUTION:

Do not pull on the harness when disconnecting the connector.

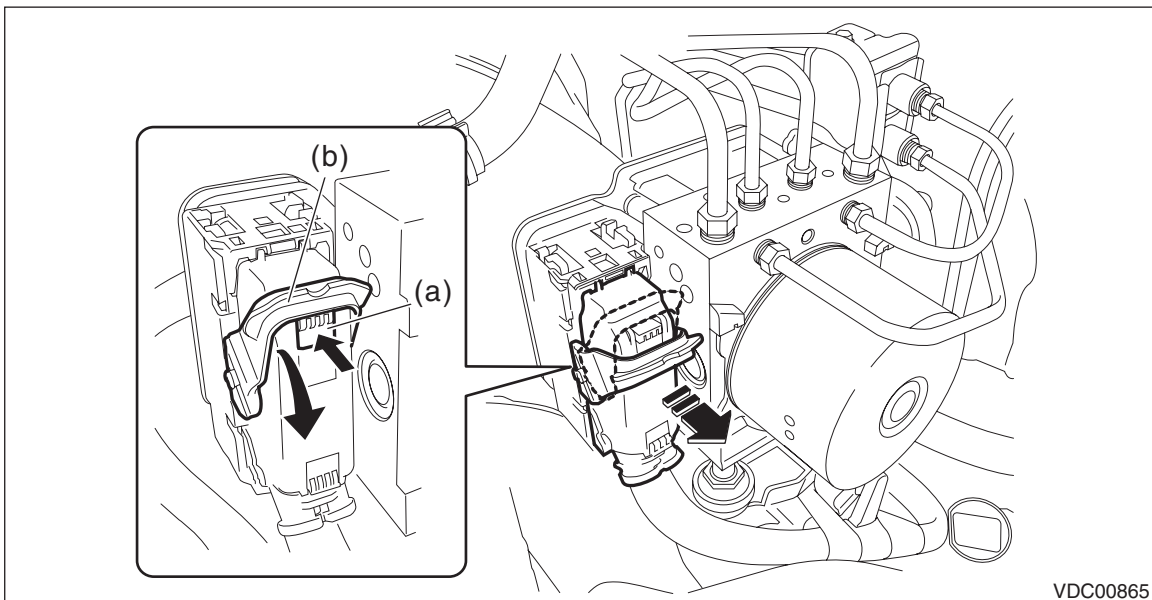

VDC Control Module and Hydraulic Control Unit (VDCCM&H/U)

VEHICLE DYNAMICS CONTROL (VDC)

(3) Using a flare nut wrench, disconnect each brake pipe from VDCCM&H/U.

CAUTION:

- Wrap the brake pipe with a vinyl bag so as not to spill the brake fluid on the painted surface of the vehicle body.
- If brake fluid is spilled on the painted surface of the vehicle body, wash it off immediately with water and wipe clean.

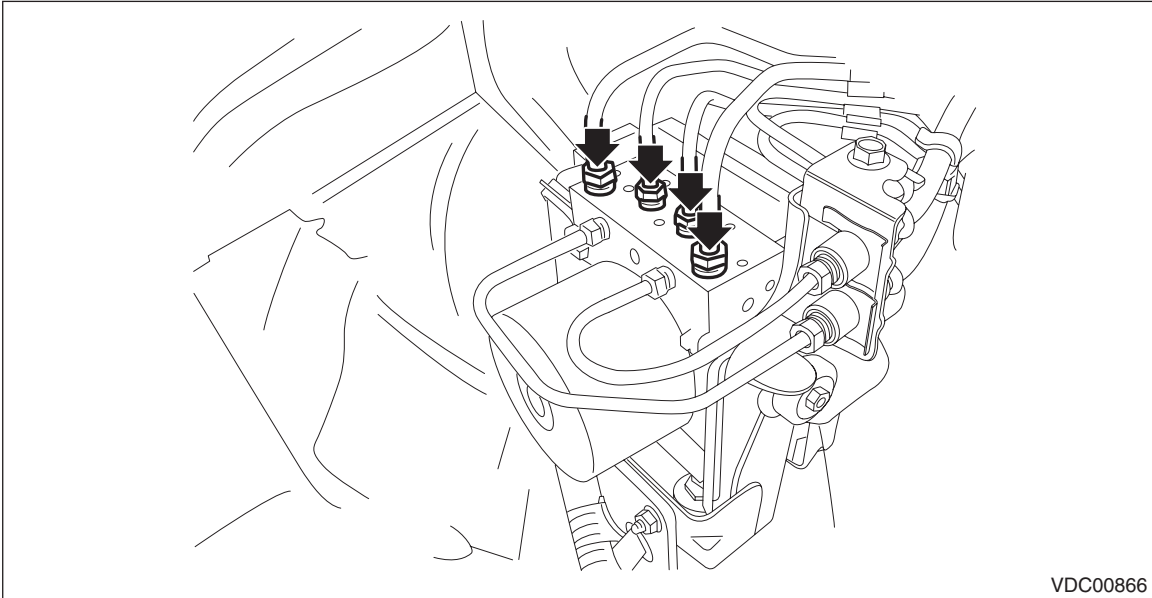

VDC00866

(4) Using a flare nut wrench, disconnect pipes (A) and (B) from VDCCM&H/U.

(5) Remove the bolt, and then remove the VDCCM&H/U from the bracket damper.

CAUTION:

- Do not drop or bump the VDCCM&H/U.
- Do not turn the VDCCM&H/U upside down or place it sideways for storage.
- Be careful not to let foreign matter enter the VDCCM&H/U.
- Be careful that no water and fluid enter the connectors.

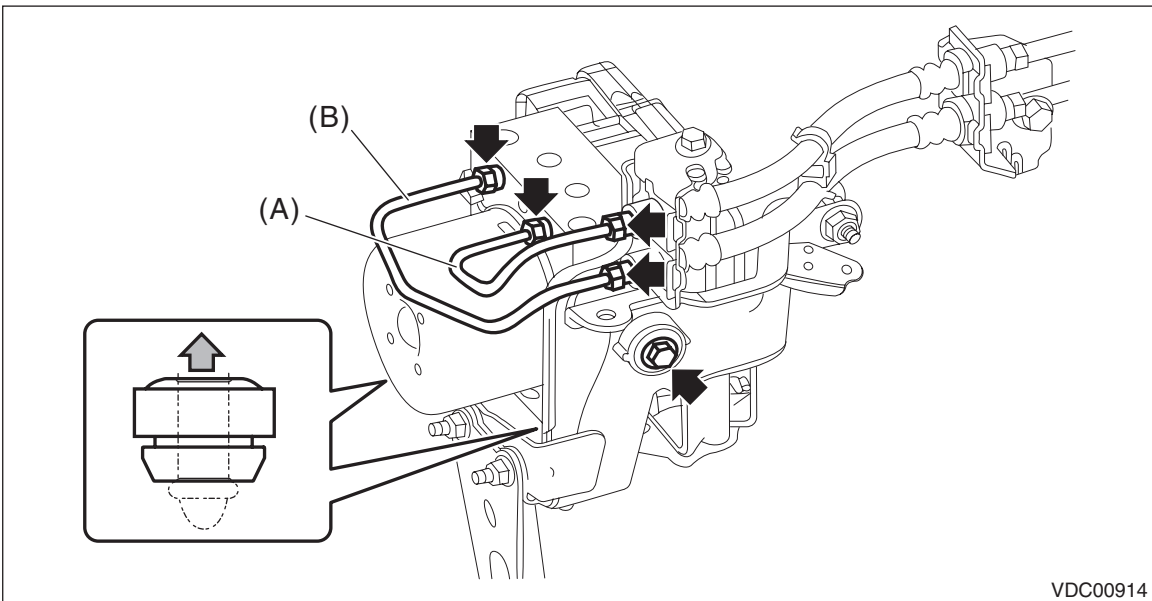

VDC00914

VDC Control Module and Hydraulic Control Unit (VDCCM&H/U)

VEHICLE DYNAMICS CONTROL (VDC)

B: INSTALLATION

CAUTION:

- When installing the VDCCM&H/U to the bracket, make sure that there is no oil adhered to the bolts and the threads of VDCCM&H/U. If the oil is adhered, degrease it carefully before tightening.
 - Connect the VDCCM&H/U connector securely.
 - When installing the VDCCM&H/U, replace the damper, spacer and nut with new parts.
- 1) Install each part in the reverse order of removal.

Tightening torque:

Refer to “COMPONENT” of “General Description”. <Ref. to VDC-5, VDC CONTROL MODULE AND HYDRAULIC CONTROL UNIT (VDCCM&H/U), COMPONENT, General Description.>

- 2) Bleed air from the brake system. <Ref. to BR-52, Air Bleeding.>
- 3) Perform parameter confirmation, selection, and registration.

NOTE:

- When the VDCCM&H/U is replaced with a new part, be sure to perform the selection · registration operation.
- For the selection and registration of parameter, the Subaru Select Monitor is required.
- When the registration has not been performed, the DTC code “Parameter selection error” is detected together with the ABS/EBD/VDC warning light illumination.
 - (1) Check that the applied model and grade of the relevant vehicle are included. <Ref. to VDC(diag)-19, PARAMETER CHECK, OPERATION, Subaru Select Monitor.>
 - (2) If the applied model and grade of the target vehicle are not included on the {Confirm on parameter} display screen, perform parameter selection and registration. <Ref. to VDC(diag)-19, PARAMETER SELECTION, OPERATION, Subaru Select Monitor.>
- 4) Perform mode setting for each sensor.
 - Set up mode for Neutral of Steering Angle Sensor & Lateral G Sensor 0 point: <Ref. to VDC-20, SET UP MODE FOR NEUTRAL OF STEERING ANGLE SENSOR & LATERAL G SENSOR 0 POINT, ADJUSTMENT, VDC Control Module and Hydraulic Control Unit (VDCCM&H/U).>
 - Longitudinal G sensor & lateral G sensor 0 point setting mode: <Ref. to VDC-20, LONGITUDINAL G SENSOR & LATERAL G SENSOR 0 POINT SETTING MODE, ADJUSTMENT, VDC Control Module and Hydraulic Control Unit (VDCCM&H/U).>

1. MODELS WITH EyeSight

CAUTION:

- When the VDCCM&H/U components are removed, be sure to perform the installation according to the following procedures to prevent fluid leakage.
 - When installing the VDCCM&H/U to the bracket, make sure that there is no oil adhered to the bolts and the threads of VDCCM&H/U. If the oil is adhered, degrease it carefully before tightening.
 - Be careful not to deform the bracket for hose assembly.
 - Connect the VDCCM&H/U connector securely.
- 1) Install the VDCCM&H/U.

NOTE:

Refer to the following figure for tightening torque.

- (1) Set the VDCCM&H/U (a) to the bracket (b).
- (2) Set the hose assembly (c) to the bracket (b).
- (3) Set pipe A (d) and pipe B (e), and temporarily tighten the flare nuts.
- (4) Tighten the VDCCM&H/U (a) and bracket (b).
- (5) Tighten the hose assembly (c) and bracket (b).
- (6) Tighten pipe A (d) and pipe B (e).
- (7) Set the center pipes (f) to hose assembly (c), and temporarily tighten the flare nuts.
- (8) Install the hose assembly (c) to the vehicle body.
- (9) Tighten the flare nuts of the center pipes (f).

(10) Install the brake pipes (g).

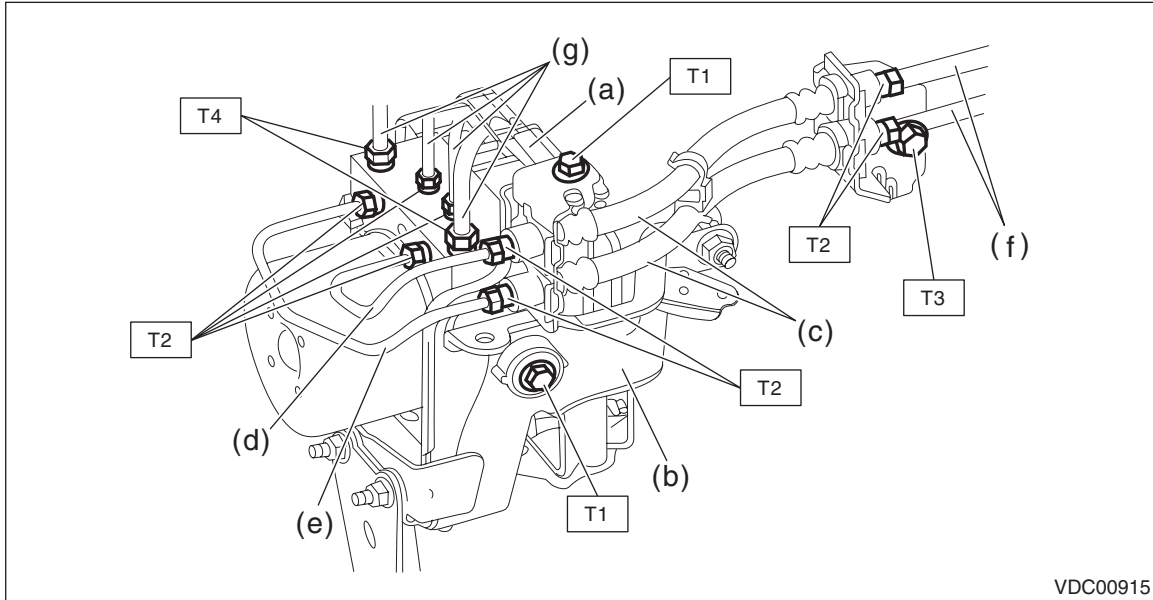

Tightening torque:

T1: 7.5 N·m (0.76 kgf-m, 5.5 ft-lb)

T2: 15 N·m (1.53 kgf-m, 11.1 ft-lb)

T3: 18 N·m (1.84 kgf-m, 13.3 ft-lb)

T4: 19 N·m (1.94 kgf-m, 14.0 ft-lb)

2) Connect the VDCCM&H/U connector.

3) Install the air intake boot.

- H4 model: <Ref. to IN(H4DO)-13, INSTALLATION, Air Intake Boot.>

- H6 model: <Ref. to IN(H6DO)-7, INSTALLATION, Air Intake Boot.>

4) Bleed air from the brake system. <Ref. to BR-52, Air Bleeding.>

5) Perform parameter confirmation, selection, and registration.

NOTE:

- When the VDCCM&H/U is replaced with a new part, be sure to perform the selection · registration operation.

- For the selection and registration of parameter, the Subaru Select Monitor is required.

- When the registration has not been performed, the DTC code “Parameter selection error” is detected together with the ABS/EBD/VDC warning light illumination.

(1) Check that the applied model and grade of the relevant vehicle are included. <Ref. to VDC(diag)-19, PARAMETER CHECK, OPERATION, Subaru Select Monitor.>

(2) If the applied model and grade of the target vehicle are not included on the {Confirm on parameter} display screen, perform parameter selection and registration. <Ref. to VDC(diag)-19, PARAMETER SELECTION, OPERATION, Subaru Select Monitor.>

6) Perform mode setting for each sensor.

- Set up mode for Neutral of Steering Angle Sensor & Lateral G Sensor 0 point: <Ref. to VDC-20, SET UP MODE FOR NEUTRAL OF STEERING ANGLE SENSOR & LATERAL G SENSOR 0 POINT, ADJUSTMENT, VDC Control Module and Hydraulic Control Unit (VDCCM&H/U).>

- Longitudinal G sensor & lateral G sensor 0 point setting mode: <Ref. to VDC-20, LONGITUDINAL G SENSOR & LATERAL G SENSOR 0 POINT SETTING MODE, ADJUSTMENT, VDC Control Module and Hydraulic Control Unit (VDCCM&H/U).>

VDC Control Module and Hydraulic Control Unit (VDCCM&H/U)

VEHICLE DYNAMICS CONTROL (VDC)

C: INSPECTION

1) Check the identification label (a) of the VDC control unit & hydraulic control unit (VDCCM&H/U).

NOTE:

For the identification label, refer to "SPECIFICATION" in "General Description". <Ref. to VDC-2, SPECIFICATION, General Description.>

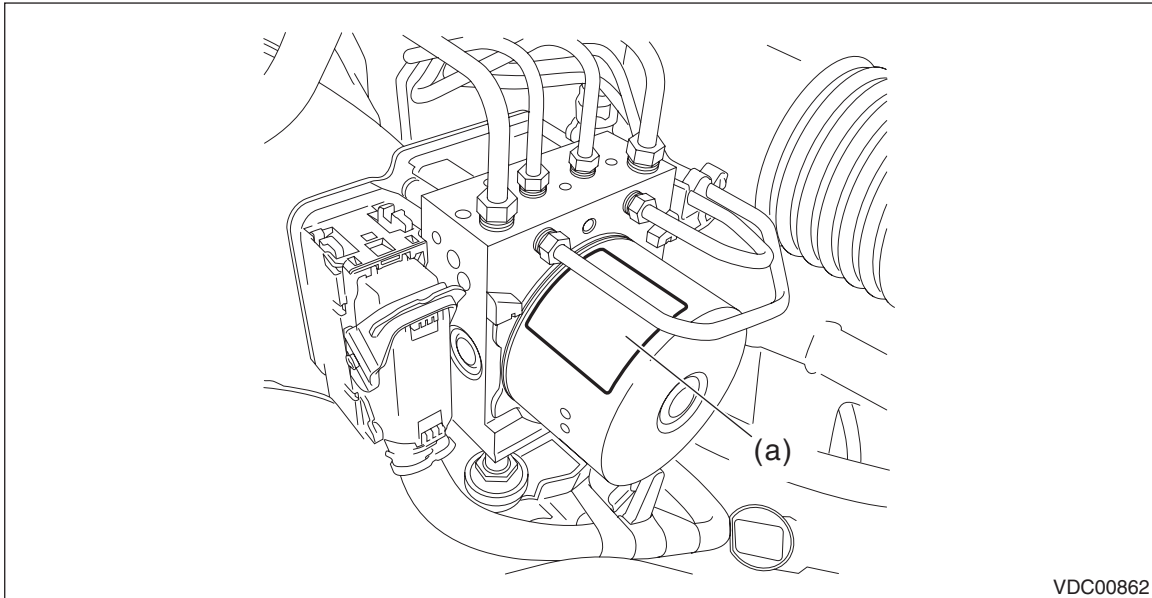

VDC00862

2) Check the condition of connection and settlement of connector, and correct or replace if defective.

1. CHECKING THE HYDRAULIC UNIT ABS OPERATION BY PRESSURE GAUGE

- 1) Lift up the vehicle, and then remove the wheel.
- 2) Remove the air bleeder screws from FL and FR caliper bodies.
- 3) Connect two pressure gauges to FL and FR caliper bodies.

CAUTION:

- Use a pressure gauge used exclusively for brake fluid measurement.
- Do not use the pressure gauge used for the measurement of transmission oil. Doing so will cause the piston seal to expand and deform.

NOTE:

Wrap sealing tape around the pressure gauge.

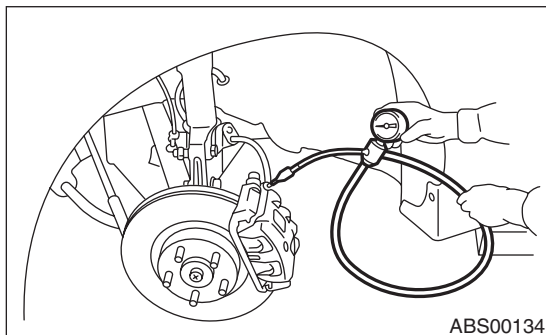

ABS00134

- 4) Bleed air from the pressure gauges and the FL and FR caliper bodies.
- 5) Perform ABS sequence control. <Ref. to VDC-21, ABS Sequence Control.>
- 6) When the hydraulic unit begins to work, first the FL side performs decompression, hold and compression, and then the FR side performs decompression, hold and compression.

VDC Control Module and Hydraulic Control Unit (VDCCM&H/U)

VEHICLE DYNAMICS CONTROL (VDC)

7) Read values indicated on the pressure gauge and check if the fluctuation of the values between decompression and compression meets the standard values. Depress the brake pedal and check that the kick-back is normal, and tightness is normal.

Inspection conditions	Front wheel	Rear wheel
Initial value	3,500 kPa (36 kgf/cm ² , 511 psi)	3,500 kPa (36 kgf/cm ² , 511 psi)
When depressurized	500 kPa (5 kgf/cm ² , 73 psi) or less	500 kPa (5 kgf/cm ² , 73 psi) or less
When pressurized	3,500 kPa (36 kgf/cm ² , 511 psi) or more	3,500 kPa (36 kgf/cm ² , 511 psi) or more

8) Disconnect the pressure gauges from FL and FR caliper bodies.

9) Install the air bleeder screws of FL and FR caliper bodies.

10) Remove the air bleeder screws from RL and RR caliper bodies.

11) Connect two pressure gauges to RL and RR caliper bodies.

12) Bleed air from RL and RR caliper bodies, and pressure gauge.

13) Perform ABS sequence control. <Ref. to VDC-21, ABS Sequence Control.>

14) When the hydraulic unit begins to work, first the RR side performs decompression, hold and compression, and then the RL side performs decompression, hold and compression.

15) Read values indicated on the pressure gauge and check if the fluctuation of the values between decompression and compression meets specification. Depress the brake pedal and check that the kick-back is normal, and tightness is normal.

16) Disconnect the pressure gauge from the RL and RR caliper bodies.

17) Install the air bleeder screws of RL and RR caliper bodies.

18) Bleed air from the brake system. <Ref. to BR-52, Air Bleeding.>

2. CHECKING THE HYDRAULIC UNIT ABS OPERATION WITH THE BRAKE TESTER

1) Set wheels other than the one to measure on free rollers.

2) Prepare for the ABS sequence control operation. <Ref. to VDC-21, ABS Sequence Control.>

3) Set the front wheels or rear wheels on the brake tester (a) and set the gear to neutral.

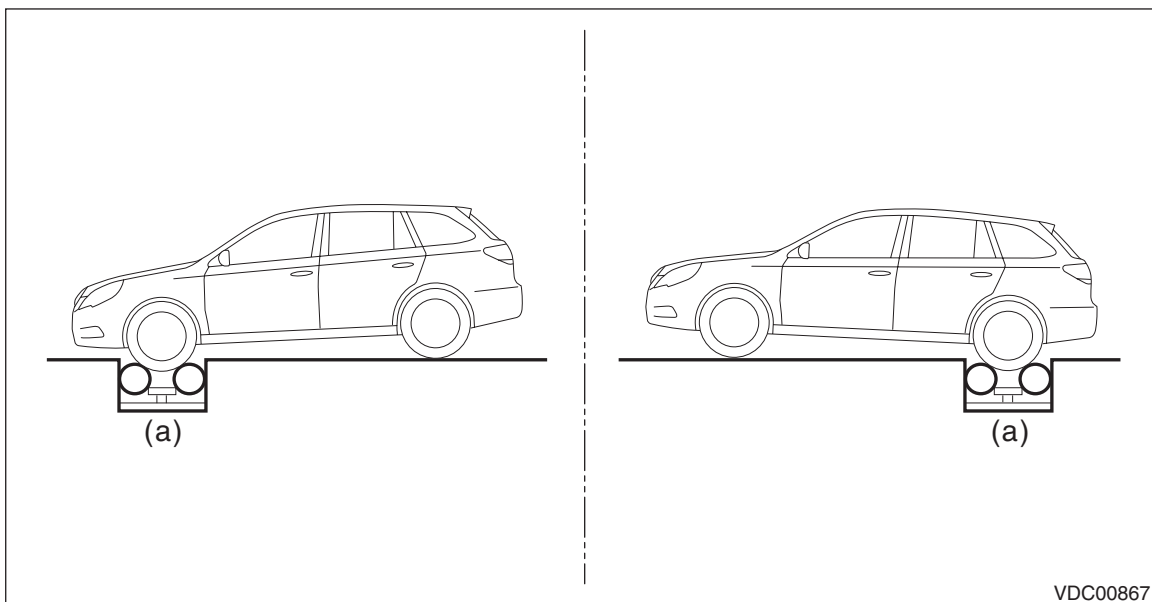

VDC00867

4) Operate the brake tester.

5) Perform ABS sequence control. <Ref. to VDC-21, ABS Sequence Control.>

6) When the hydraulic unit begins to work, check the following work sequence.

(1) The FL wheel performs decompression, hold and compression in sequence, and subsequently the FR wheel repeats the cycle.

VDC Control Module and Hydraulic Control Unit (VDCCM&H/U)

VEHICLE DYNAMICS CONTROL (VDC)

- (2) The RR wheel performs decompression, hold and compression in sequence, and subsequently the RL wheel repeats the cycle.
- 7) Read values indicated on the brake tester and check if the fluctuation of the values between decompression and compression meets specification.

Inspection conditions	Front wheel	Rear wheel
Initial value	1,000 N (102 kgf, 225 lb)	1,000 N (102 kgf, 225 lb)
When depressurized	500 N (51 kgf, 112 lb) or less	500 N (51 kgf, 112 lb) or less
When pressurized	1,000 N (102 kgf, 225 lb) or more	1,000 N (102 kgf, 225 lb) or more

- 8) After the inspection, depress the brake pedal and check that it is not abnormally hard, and tightness is normal.

3. CHECKING THE HYDRAULIC UNIT VDC OPERATION USING A PRESSURE GAUGE

- 1) Lift up the vehicle, and then remove the wheel.
- 2) Remove the air bleeder screws from FL and FR caliper bodies.
- 3) Connect two pressure gauges to FL and FR caliper bodies.

CAUTION:

- Use a pressure gauge used exclusively for brake fluid measurement.
- Do not use a pressure gauge used for the measuring transmission oil pressure, as the piston seal may expand and deform.

NOTE:

Wrap sealing tape around the pressure gauge.

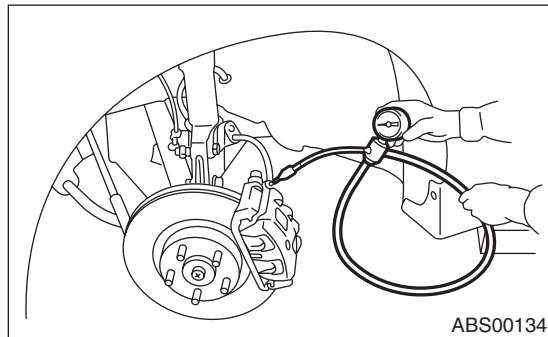

- 4) Bleed air from the pressure gauge.
- 5) Perform VDC sequence control. <Ref. to VDC-24, VDC Sequence Control.>
- 6) When the hydraulic unit begins to work, first the FL side performs compression, hold, and decompression, and then the FR side performs compression, hold, and decompression.
- 7) Read values indicated on the pressure gauge and check if the fluctuation of the values between decompression and compression meets specification. Depress the brake pedal and check that it is not abnormally hard, and tightness is normal.

Inspection conditions	Front wheel	Rear wheel
When pressurized	3,000 kPa (31 kgf/cm ² , 441 psi) or more	3,000 kPa (31 kgf/cm ² , 441 psi) or more
When depressurized	500 kPa (5 kgf/cm ² , 73 psi) or less	500 kPa (5 kgf/cm ² , 73 psi) or less

- 8) Disconnect the pressure gauges from FL and FR caliper bodies.
- 9) Install the air bleeder screws of FL and FR caliper bodies.

- 10) Remove the air bleeder screws from RL and RR caliper bodies.
- 11) Connect two pressure gauges to RL and RR caliper bodies.
- 12) Bleed air from RL and RR caliper bodies, and pressure gauge.
- 13) Perform VDC sequence control. <Ref. to VDC-24, VDC Sequence Control.>
- 14) When the hydraulic unit begins to work, first the RR side performs compression, hold, and decompression, and then the RL side performs compression, hold, and decompression.
- 15) Read the values indicated on the pressure gauges and check if it is within specification. Depress the brake pedal and check that it is not abnormally hard, and tightness is normal.
- 16) Disconnect the pressure gauge from the RL and RR caliper bodies.
- 17) Install the air bleeder screws of RL and RR caliper bodies.
- 18) Bleed air from the brake system. <Ref. to BR-52, Air Bleeding.>

4. CHECK HYDRAULIC UNIT VDC OPERATION WITH BRAKE TESTER

- 1) Set wheels other than the one to measure on free rollers.
- 2) Prepare to operate the VDC sequence control. <Ref. to VDC-24, VDC Sequence Control.>
- 3) Set the front wheels or rear wheels on the brake tester (a) and set the gear to neutral.

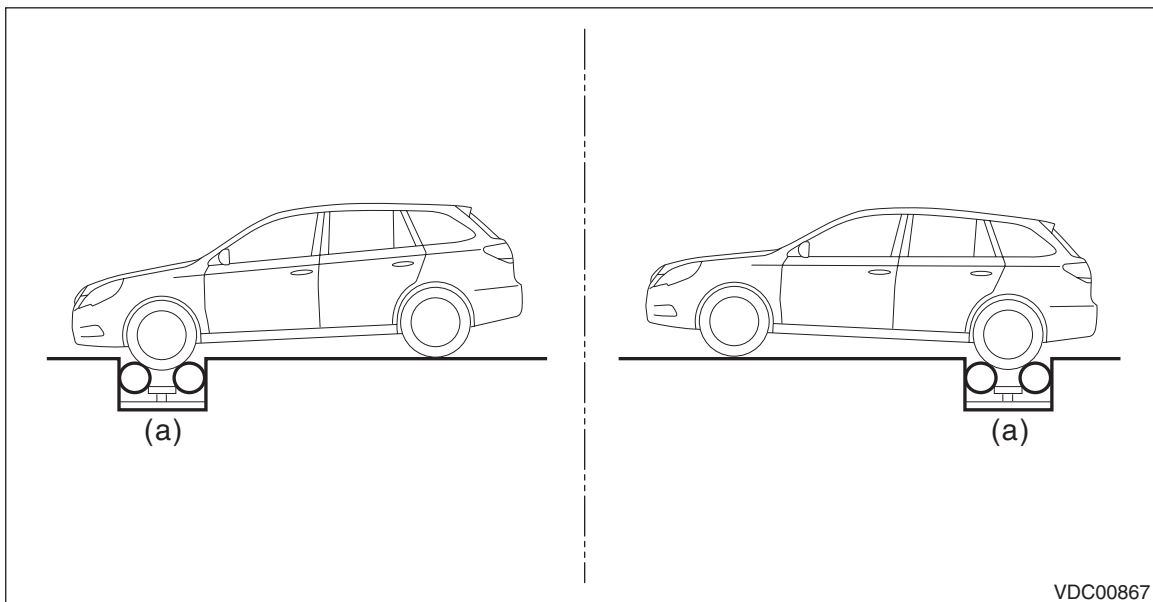

- 4) Operate the brake tester.
- 5) Perform VDC sequence control. <Ref. to VDC-24, VDC Sequence Control.>
- 6) When the hydraulic unit begins to work, check the following work sequence.
 - (1) The FL wheel performs compression, hold and decompression in sequence, and subsequently the FR wheel repeats the cycle.
 - (2) The RR wheel performs compression, hold and decompression in sequence, and subsequently the RL wheel repeats the cycle.
- 7) Read values indicated on the brake tester and check if the fluctuation of the values between decompression and compression meets specification.

Inspection conditions	Front wheel	Rear wheel
When pressurized	2,000 N (204 kgf, 450 lbf) or more	2,000 N (204 kgf, 450 lbf) or more
When depressurized	500 N (51 kgf, 112 lbf) or less	500 N (51 kgf, 112 lbf) or less

- 8) After the inspection, depress the brake pedal and check that it is not abnormally hard, and tightness is normal.

VDC Control Module and Hydraulic Control Unit (VDCCM&H/U)

VEHICLE DYNAMICS CONTROL (VDC)

D: ADJUSTMENT

1. SET UP MODE FOR NEUTRAL OF STEERING ANGLE SENSOR & LATERAL G SENSOR 0 POINT

After installing, replacing, or adjusting the following part, perform the Set up mode for Neutral of Steering Angle Sensor & Lateral G Sensor 0 point.

- Steering angle sensor
- Steering wheel
- Suspension parts
- Wheel alignment
- VDCCM&H/U
- VDCCM&H/U bracket

- 1) Set the steering wheel to the neutral position.
- 2) Connect the Subaru Select Monitor to data link connector.
 - (1) Run the "PC application for Subaru Select Monitor".
 - (2) On «Main Menu» display, select {Each System Check}.
 - (3) Select {Brake Control System}. When {VDC} is displayed, select the [OK] button.
 - (4) From {Current Data Display & Save}, select {Steer Angle Sensor Op}.
- 3) Check that the steering angle sensor output value is between -10 and 10 deg.
- 4) From {Function Check Sequence}, select {Set up mode for Neutral of Steering Angle Sensor & Lateral G Sensor 0 point}, and perform the setting according to the procedure displayed on the Subaru Select Monitor Screen.
- 5) Drive the vehicle for 10 minutes, and check that there is no system malfunction or the warning light illumination while driving.
- 6) Make sure that the DTC is not stored.

2. LONGITUDINAL G SENSOR & LATERAL G SENSOR 0 POINT SETTING MODE

After installing or replacing the following part, perform the longitudinal G sensor & lateral G sensor 0 point setting mode.

- Suspension parts
- VDCCM&H/U
- VDCCM&H/U bracket

- 1) Park the vehicle on a level surface with all wheels aligned straight.
- 2) Connect the Subaru Select Monitor to data link connector.
 - (1) Run the "PC application for Subaru Select Monitor".
 - (2) On «Main Menu» display, select {Each System Check}.
 - (3) Select {Brake Control System}. When {VDC} is displayed, select the [OK] button.
 - (4) From {Current Data Display & Save}, select {Longitudinal G Sensor Output} and {Lateral G Sensor Output}.
- 3) Check that output values for the longitudinal G sensor and lateral G sensor are $-2 \text{ — } 2 \text{ m/s}^2$.
- 4) From {Function Check Sequence}, select {Longitudinal G Sensor & Lateral G Sensor 0 Point Setting Mode}, and perform the setting according to the procedure displayed on the Subaru Select Monitor Screen.
- 5) Drive the vehicle for 10 minutes, and check that there is no system malfunction or the warning light illumination while driving.
- 6) Make sure that the DTC is not stored.