

## 4. Tire Pressure Monitoring System

### A: REMOVAL

#### 1. TRANSMITTER (TIRE INFLATION PRESSURE SENSOR)

- 1) Remove the wheels from the vehicle. <Ref. to WT-4, REMOVAL, Tire and Wheel.>
- 2) Remove the tires from wheels.

**CAUTION:**

**Use a tire changer when removing the tire from the wheel.**

- 3) Loosen the screw to remove the transmitter from the valve stem.

**CAUTION:**

**Do not reuse the valve and screw.**

**Replace the valve and screw with a new part even when reusing transmitter.**

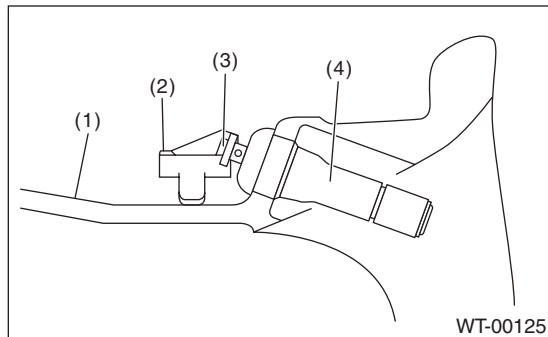

- (1) Wheel
- (2) Transmitter
- (3) Screw
- (4) Valve

- 4) Remove the valve from the wheel.

# Tire Pressure Monitoring System

## WHEEL AND TIRE SYSTEM

### 2. TPMS & KEYLESS CONTROL MODULE

#### NOTE:

TPMS control module is integrated with the keyless entry control module. (Model without keyless access)

#### Sedan model

- 1) Disconnect the ground cable from battery.
- 2) Remove the rear shelf trim. <Ref. to EI-123, REMOVAL, Rear Shelf Trim.>
- 3) Remove the TPMS & keyless control module.
  - (1) Disconnect the connector.
  - (2) Remove the bolt and then remove the TPMS & keyless control module.

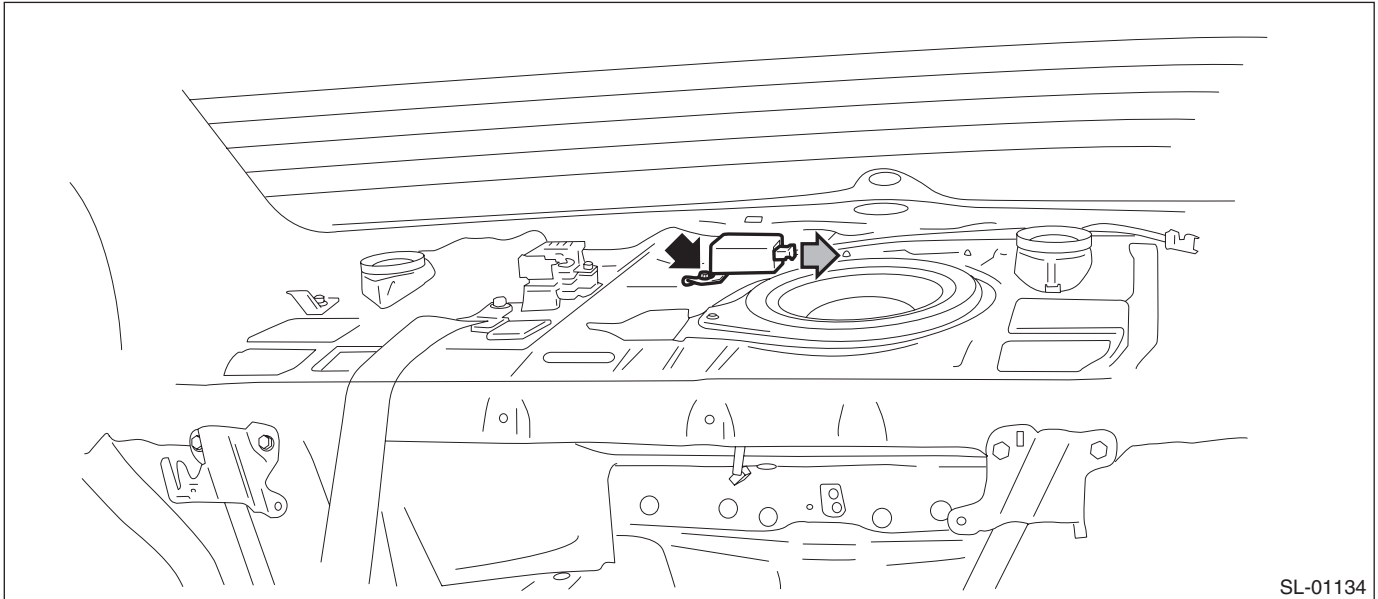

#### OUTBACK model

- 1) Disconnect the ground cable from battery.
- 2) Remove the rear quarter trim LH. <Ref. to EI-111, REMOVAL, Rear Quarter Trim.>
- 3) Remove the TPMS & keyless control module.
  - (1) Disconnect the connector.
  - (2) Remove the bolt and then remove the TPMS & keyless control module.

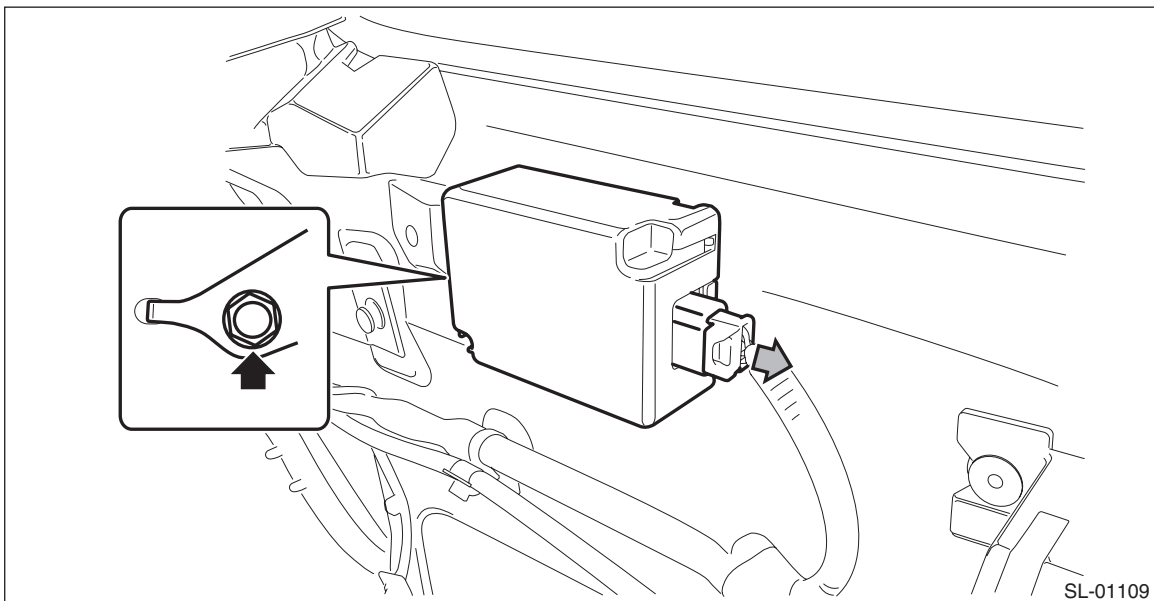

## 3. TPMS CM

**NOTE:**

TPMS control module is separated from the keyless entry control module and is installed under the driver's seat. (Model with keyless access)

- 1) Disconnect the ground cable from battery.
- 2) Remove the front seat assembly. <Ref. to SE-10, REMOVAL, Front Seat.>
- 3) Remove the rear seat cushion assembly. <Ref. to SE-34, REMOVAL, Rear Seat.>
- 4) Remove the lower inner trim. <Ref. to EI-97, REMOVAL, Lower Inner Trim.>
- 5) Turn up the driver's side floor mat so that the TPMS CM can be removed.
- 6) Remove the TPMS CM.
  - (1) Disconnect the connector.
  - (2) Remove the nuts to remove the TPMS CM.

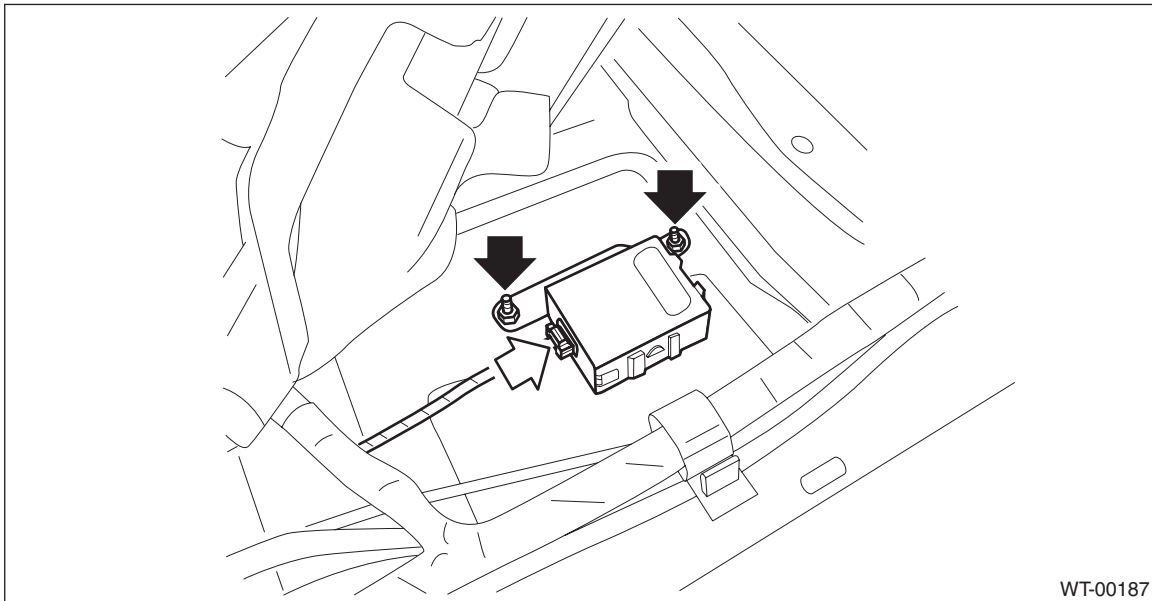

## B: INSTALLATION

### 1. TRANSMITTER (TIRE INFLATION PRESSURE SENSOR)

**CAUTION:**

**Use the new transmitter assembly or replace the new valve and screw, when installing.**

- 1) Replace the valve and screw with a new part when reusing transmitter.

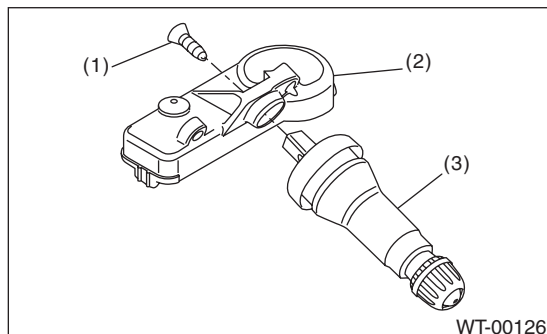

- (1) Screw
- (2) Transmitter
- (3) Valve

**Tightening torque:**

**1.4 N·m (0.14 kgf-m, 1.0 ft-lb)**

# Tire Pressure Monitoring System

## WHEEL AND TIRE SYSTEM

---

2) Install the transmitter to the wheel by aligning it with valve hole.

### NOTE:

When using the jig that pulls the valve cap by hooking its neck part, use another short-type cap.

3) Install the tires to wheels.

### CAUTION:

- Use a tire changer when installing tire to wheel.
- To prevent damaging the transmitter, set the tire changer boom in the position as shown in the figure.

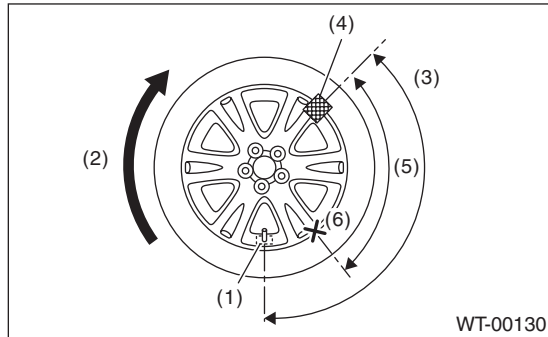

- (1) Transmitter
- (2) Direction of turn table rotation
- (3) 135°
- (4) Tire changer boom
- (5) 90°
- (6) Starting point for fitting the bead to the rim

4) Install the wheels to vehicle. <Ref. to WT-4, INSTALLATION, Tire and Wheel.>

5) Register the transmitter ID to the TPMS & keyless control module. <Ref. to TPM(diag)-13, Register Transmitter (ID).>

## 2. TPMS & KEYLESS CONTROL MODULE

Install each part in the reverse order of removal.

### Tightening torque:

**7.5 N·m (0.76 kgf-m, 5.5 ft-lb)**

## 3. TPMS CM

Install each part in the reverse order of removal.

### Tightening torque:

**8 N·m (0.82 kgf-m, 5.9 ft-lb)**

## C: ADJUSTMENT

Re-register the transmitter ID when transmitter has been replaced. <Ref. to TPM(diag)-13, Register Transmitter (ID).>