

4. Horn

A: REMOVAL

- 1) Disconnect the ground cable from battery.
- 2) Remove the Lo pitch side horn.
 - (1) Remove the clips and remove the air intake duct.

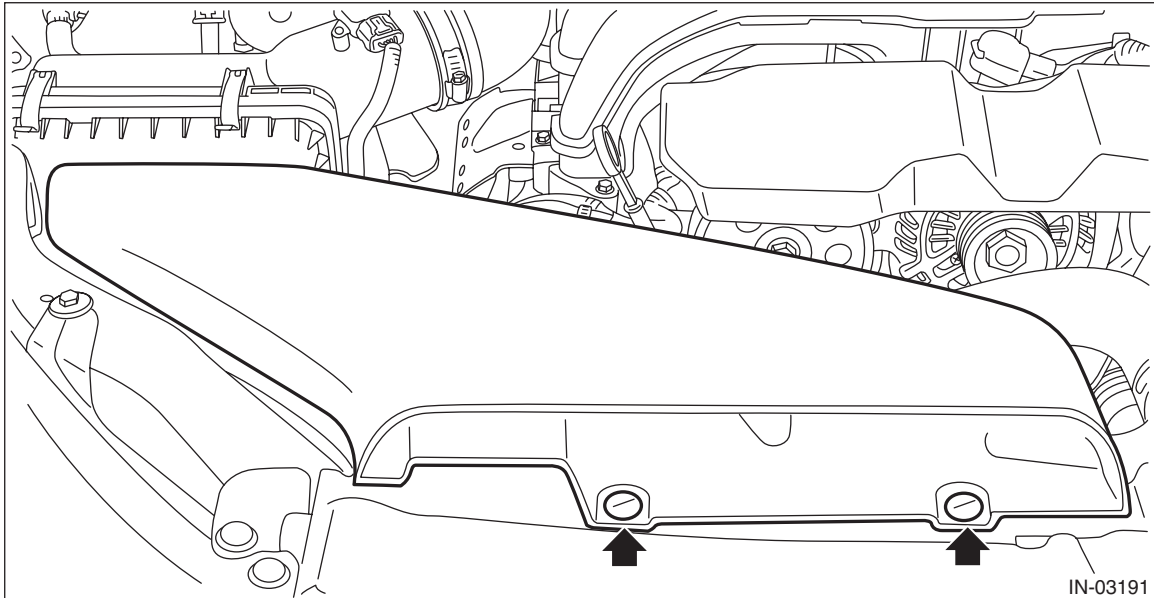

- (2) Remove the clips and remove the grille bracket.

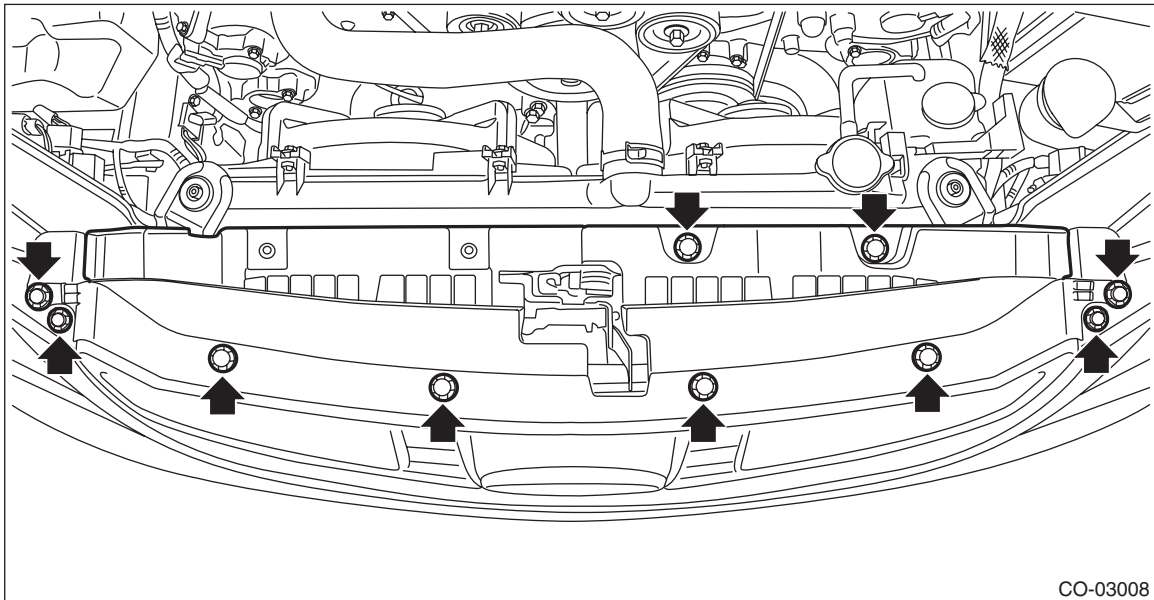

- (3) Disconnect the connector.

Horn

COMMUNICATION SYSTEM

- (4) Remove the horn bracket mounting bolt, and remove the Lo pitch side horn.

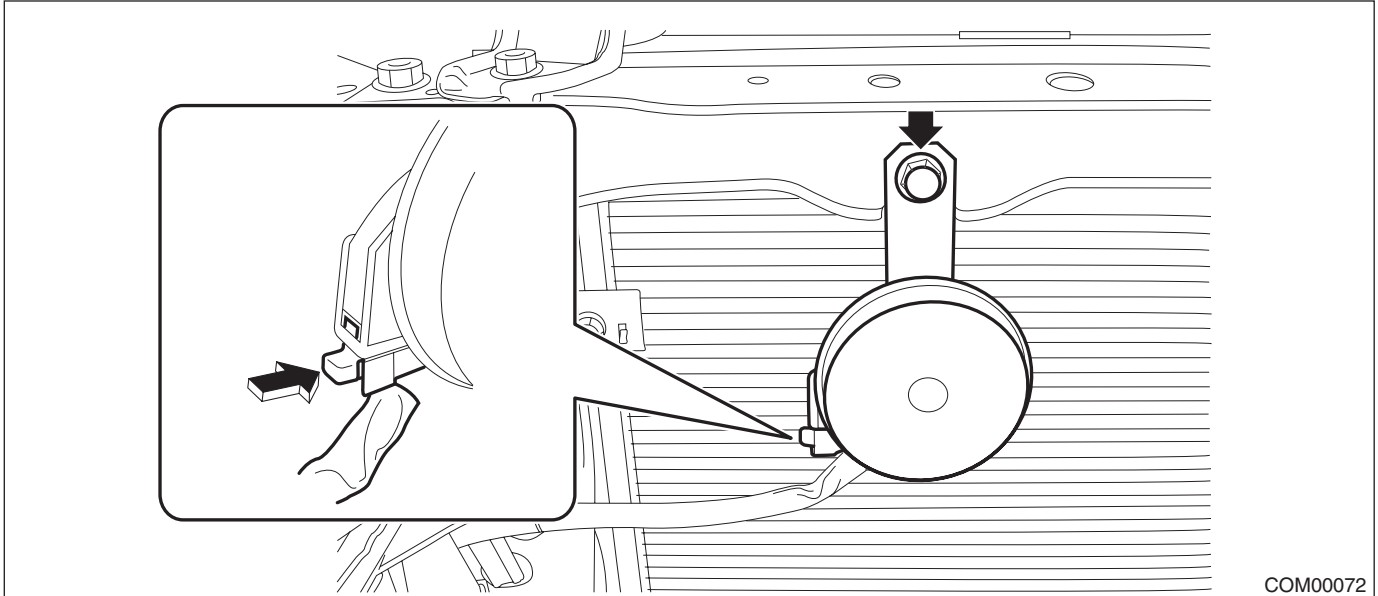

- 3) Remove the Hi pitch side horn.

- (1) Remove the clips and turn over the front mud guard RH.

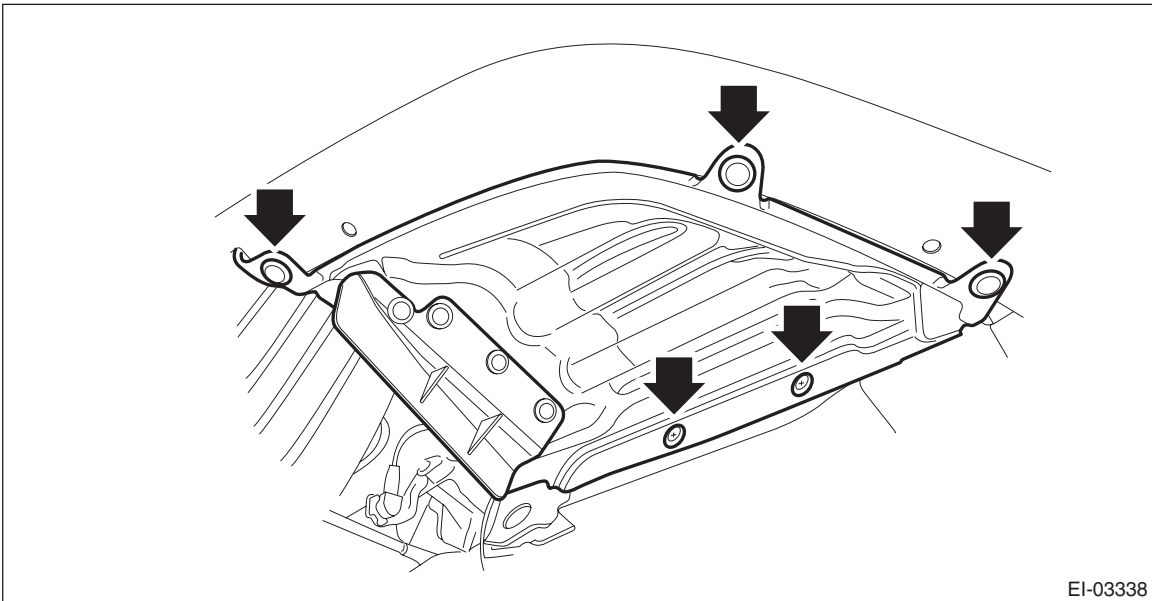

- (2) Disconnect the connector.

(3) Remove the horn bracket mounting bolt, and remove the Hi pitch side horn.

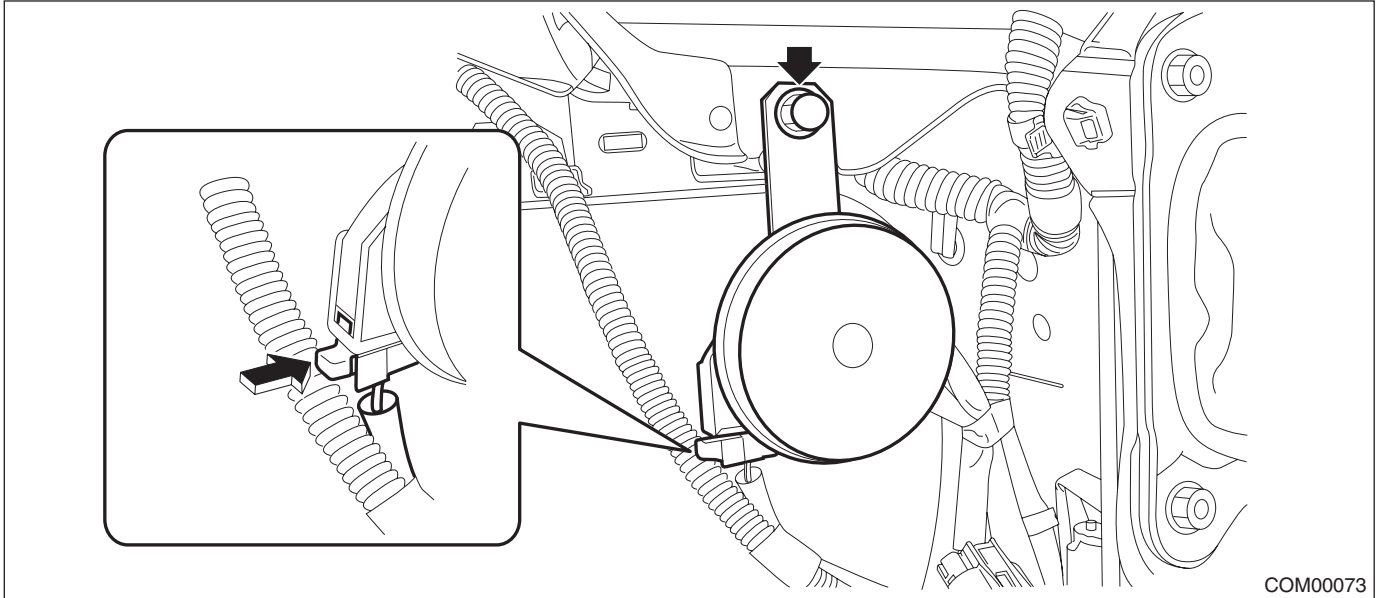

COM00073

B: INSTALLATION

1) Install each part in the reverse order of removal.

Tightening torque:

Horn assembly: 18 N·m (1.84 kgf·m, 13.3 ft·lb)

2) Adjust the fog light beam. (Model with fog light) <Ref. to LI-42, FOG LIGHT AIMING, ADJUSTMENT, Front Fog Light Assembly.>

C: INSPECTION

1. CHECK HORN ASSEMBLY

- 1) Remove the horn assembly (Hi pitch side and Lo pitch side). <Ref. to COM-5, REMOVAL, Horn.>
- 2) Check the horn sounds when applying the battery voltage to the horn assembly.

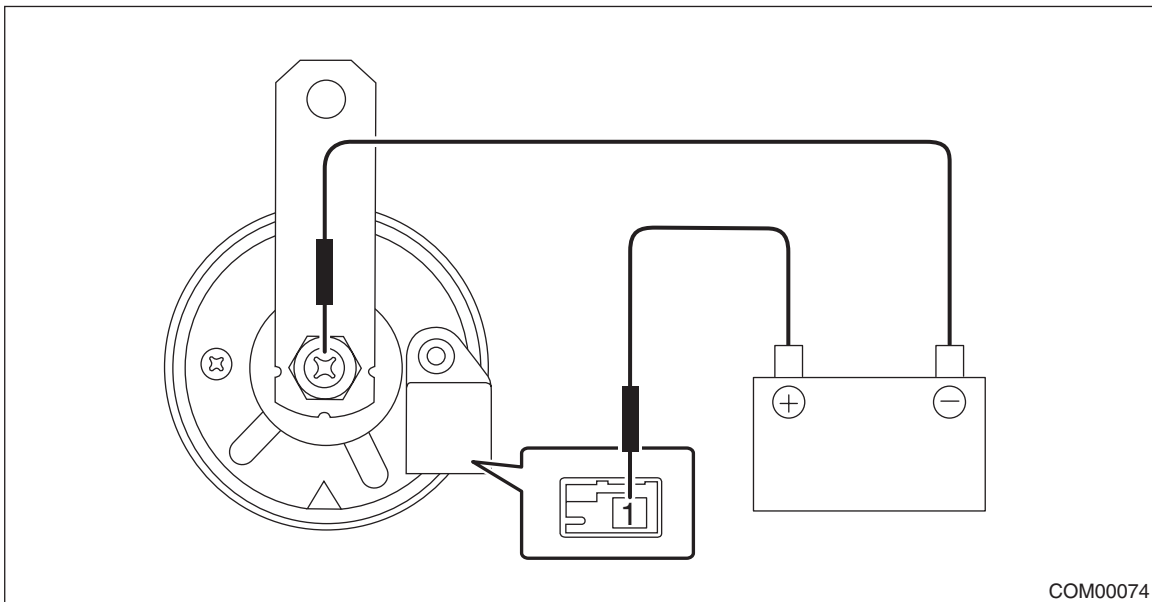

COM00074

Terminal No.	Inspection conditions	Specification
1 (+) — Horn case (-)	Connect battery to the terminals	Sounds

3) If it does not operate normally, replace the horn assembly.