

## 5. Cruise Control Command Switch

### A: REMOVAL

- 1) Position the front wheels straight ahead. (After moving a vehicle 5 m (16 ft) or more with front wheels positioned straight ahead, make sure that the vehicle moves straight ahead.)
- 2) Turn the ignition switch to OFF.
- 3) Disconnect the ground cable from battery and wait for at least 60 seconds before starting work.
- 4) Remove the driver's airbag module assembly.

#### CAUTION:

Before handling the airbag module, refer to "CAUTION" of "General Description" in "AIRBAG SYSTEM". <Ref. to AB-10, CAUTION, General Description.>

- (1) Using a hexagon wrench etc. wrapped by protective tape, insert the snap pins and release the locks (3 locations).

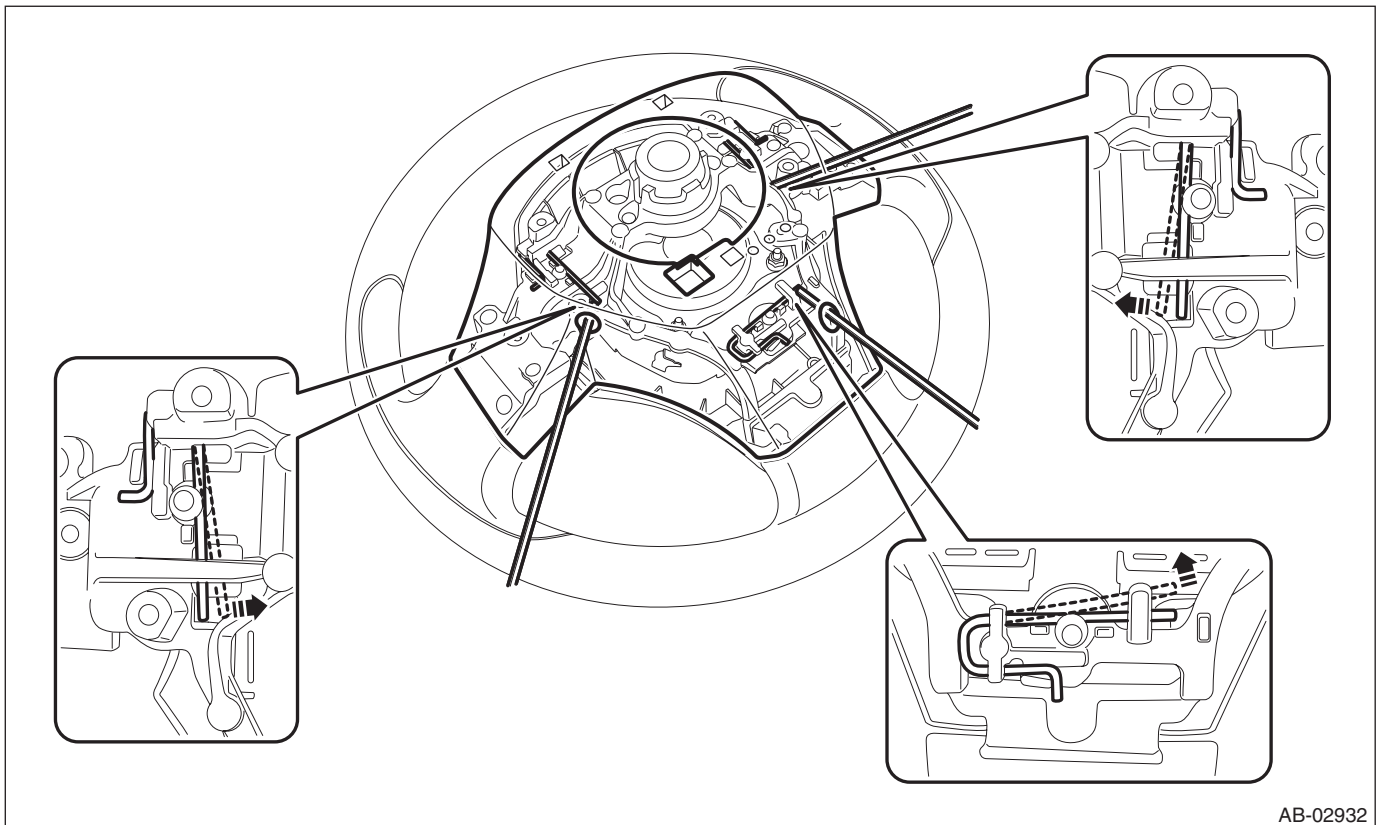

AB-02932

# Cruise Control Command Switch

## CRUISE CONTROL SYSTEM

(2) Disconnect the horn harness and airbag connector and remove the airbag module assembly. <Ref. to AB-22, DRIVER'S AIRBAG MODULE, CURTAIN AIRBAG MODULE, PRETENSIONER & LAP SEAT BELT PRETENSIONER, PROCEDURE, Airbag Connector.>

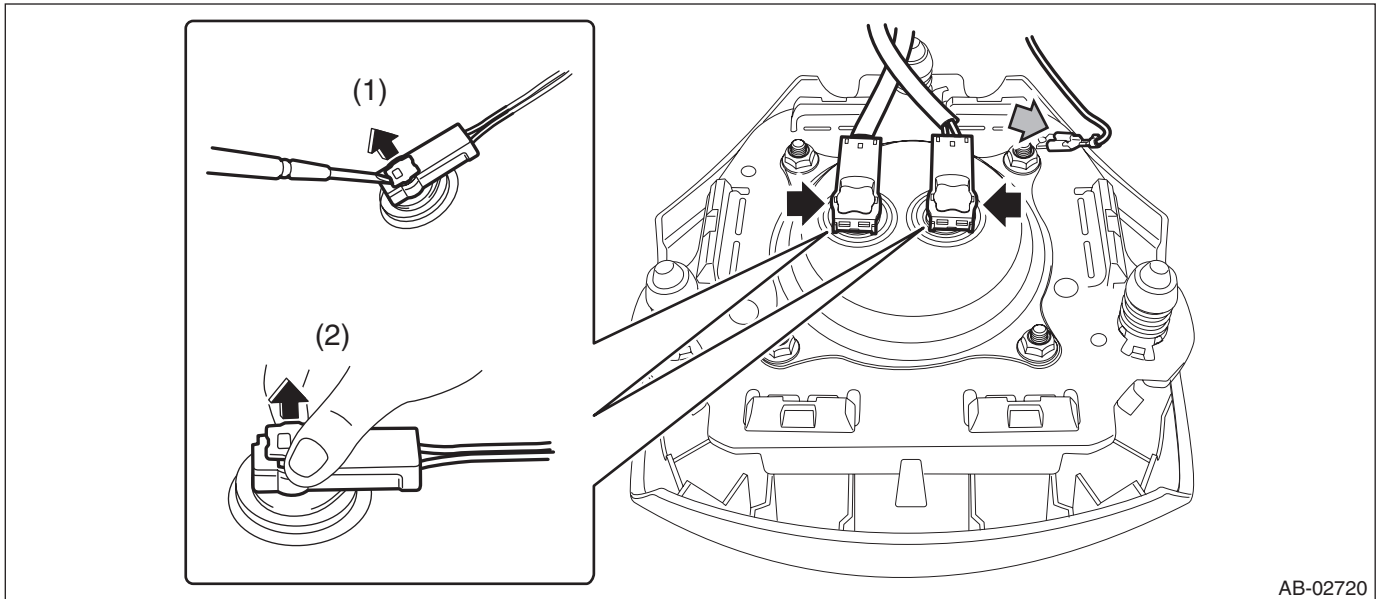

5) Remove the steering wheel.

### CAUTION:

- Always use the steering wheel puller for removal to avoid deforming the steering wheel.
- If the steering wheel has been removed, make sure that the roll connector is not turned from the original position.

(1) Disconnect the connector and remove the nut.

(2) Put alignment marks and remove the steering wheel using a steering wheel puller.

### Preparation tool:

**Steering wheel puller**

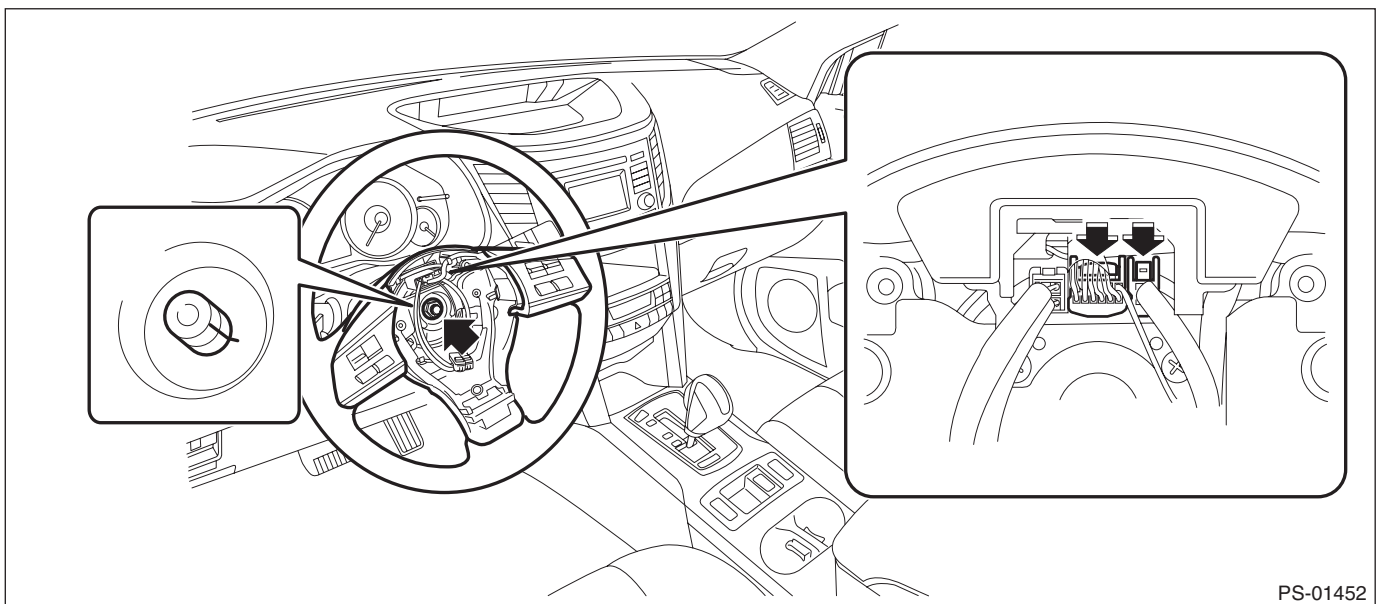

# Cruise Control Command Switch

6) Remove the cruise control command switch.

(1) Remove the screw, disconnect the connector and remove the paddle shift switch. (Model with paddle shift)

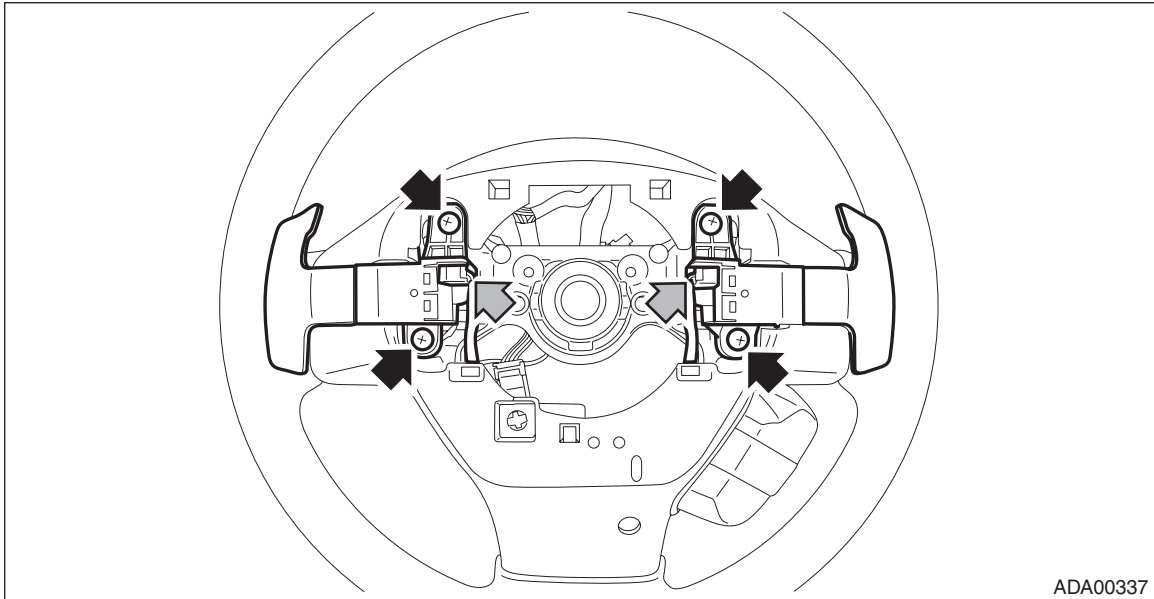

ADA00337

(2) Remove the steering switch connector and screw. (luminescent meter model)

(3) Disconnect the claws and then remove the lower cover.

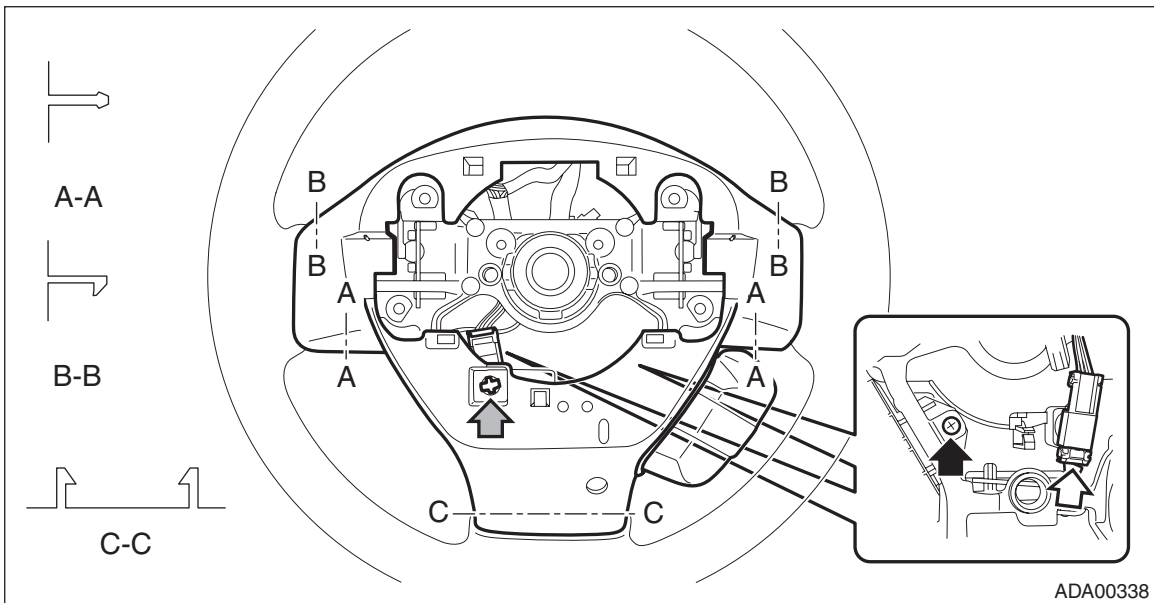

ADA00338

# Cruise Control Command Switch

## CRUISE CONTROL SYSTEM

(4) Remove the screw to remove the cruise control command switch assembly.

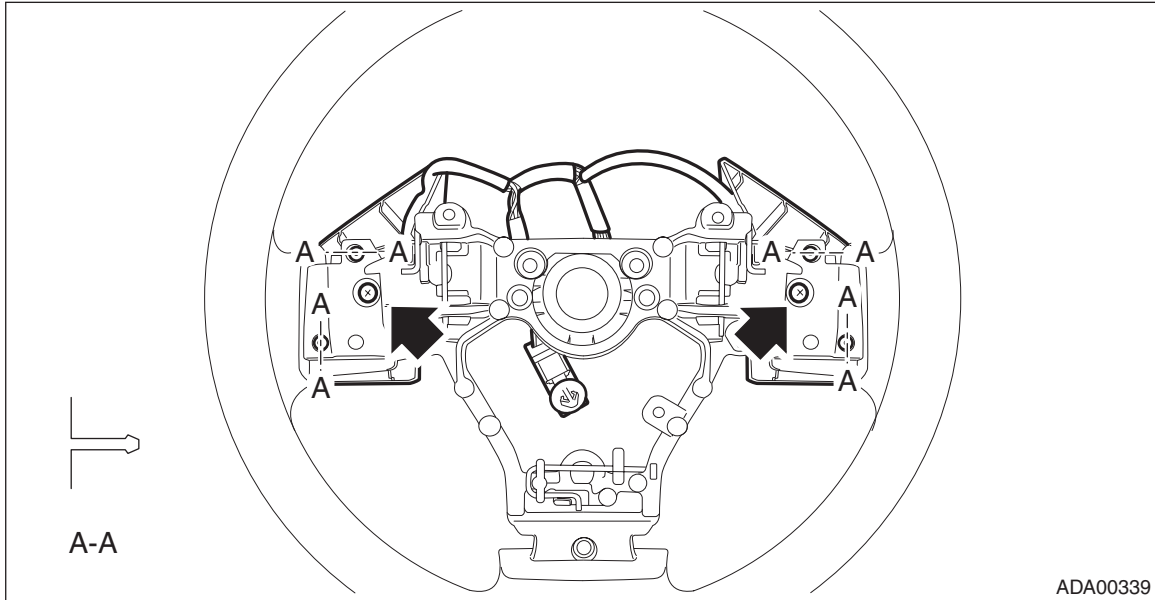

## B: INSTALLATION

### CAUTION:

- Before handling the airbag module, refer to “CAUTION” of “General Description” in “AIRBAG SYSTEM”. <Ref. to AB-10, CAUTION, General Description.>
- Do not allow harness and connectors to interfere or get tangled up with other parts.
- If the steering wheel and steering angle sensor (steering roll connector) are removed, adjust the steering angle sensor. <Ref. to VDC-20, ADJUSTMENT, VDC Control Module and Hydraulic Control Unit (VDCCM&H/U).>

1) Before installing steering wheel, be sure to adjust the direction of roll connector with steering. <Ref. to AB-109, ADJUSTMENT, Roll Connector.>

2) Install each part in the reverse order of removal.

### NOTE:

Align the alignment marks on the steering wheel and steering column.

### *Tightening torque:*

***Steering wheel: 39 N·m (3.98 kgf·m, 28.8 ft·lb)***

### *Clearance:*

***Between column cover and steering wheel: 4 — 6 mm (0.16 — 0.24 in)***

## C: INSPECTION

- 1) Disconnect the cruise control command switch connector.
- 2) Check the resistance between cruise control command switch terminals.

**Preparation tool:**  
**Circuit tester**

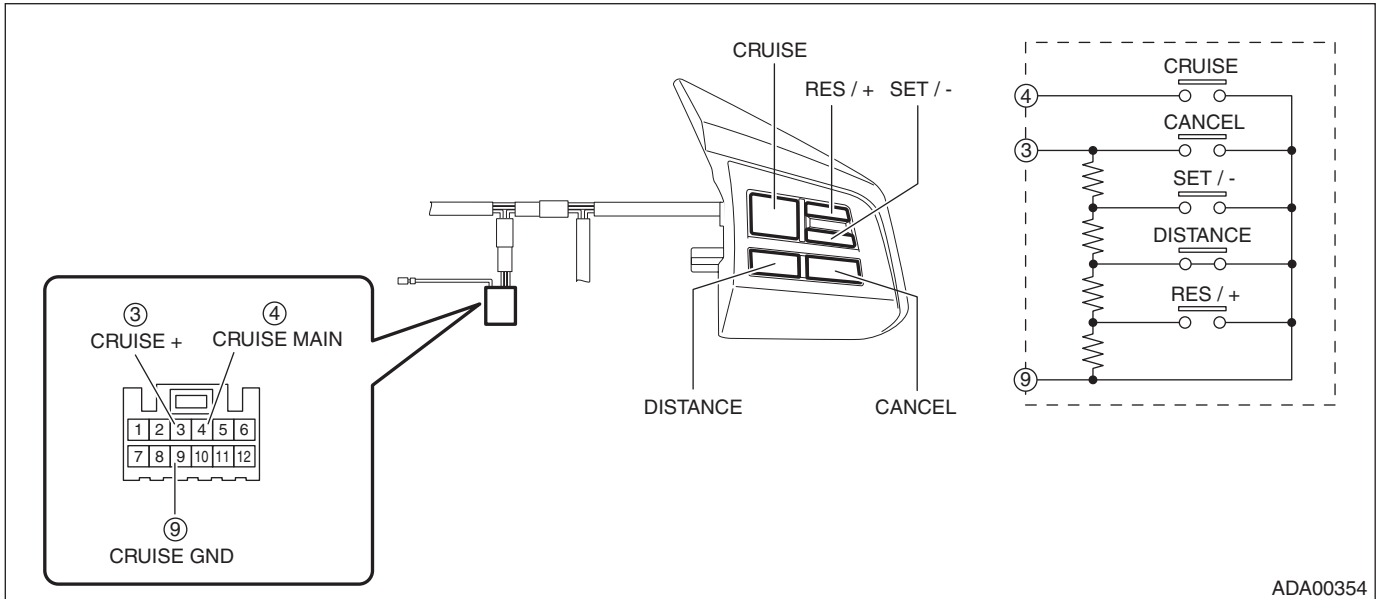

Terminal No.	Inspection conditions		Standard
3 — 9	CANCEL SET/- RES/+	All OFF	Approx. 4 kΩ
3 — 9	CANCEL	ON	Less than 1 Ω
3 — 9	SET/-	ON	Approx. 250 Ω
3 — 9	RES/+	ON	Approx. 1,470 Ω
4 — 9	CRUISE	OFF	1 MΩ or more
4 — 9	(MAIN)	ON	Less than 1 Ω

- 3) Replace the cruise control command switch if the inspection result is not within the standard.