

11. Steering Satellite Switch

A: REMOVAL

- 1) Position the front wheels straight ahead. (After moving a vehicle 5 m (16 ft) or more with front wheels positioned straight ahead, make sure that the vehicle moves straight ahead.)
- 2) Turn the ignition switch to OFF.
- 3) Disconnect the ground cable from battery and wait for at least 60 seconds before starting work.
- 4) Remove the driver's airbag module assembly.

CAUTION:

Before handling the airbag module, refer to "CAUTION" of "General Description" in "AIRBAG SYSTEM". <Ref. to AB-10, CAUTION, General Description.>

- (1) Using a hexagon wrench etc. wrapped by protective tape, insert the snap pins and release the locks (3 locations).

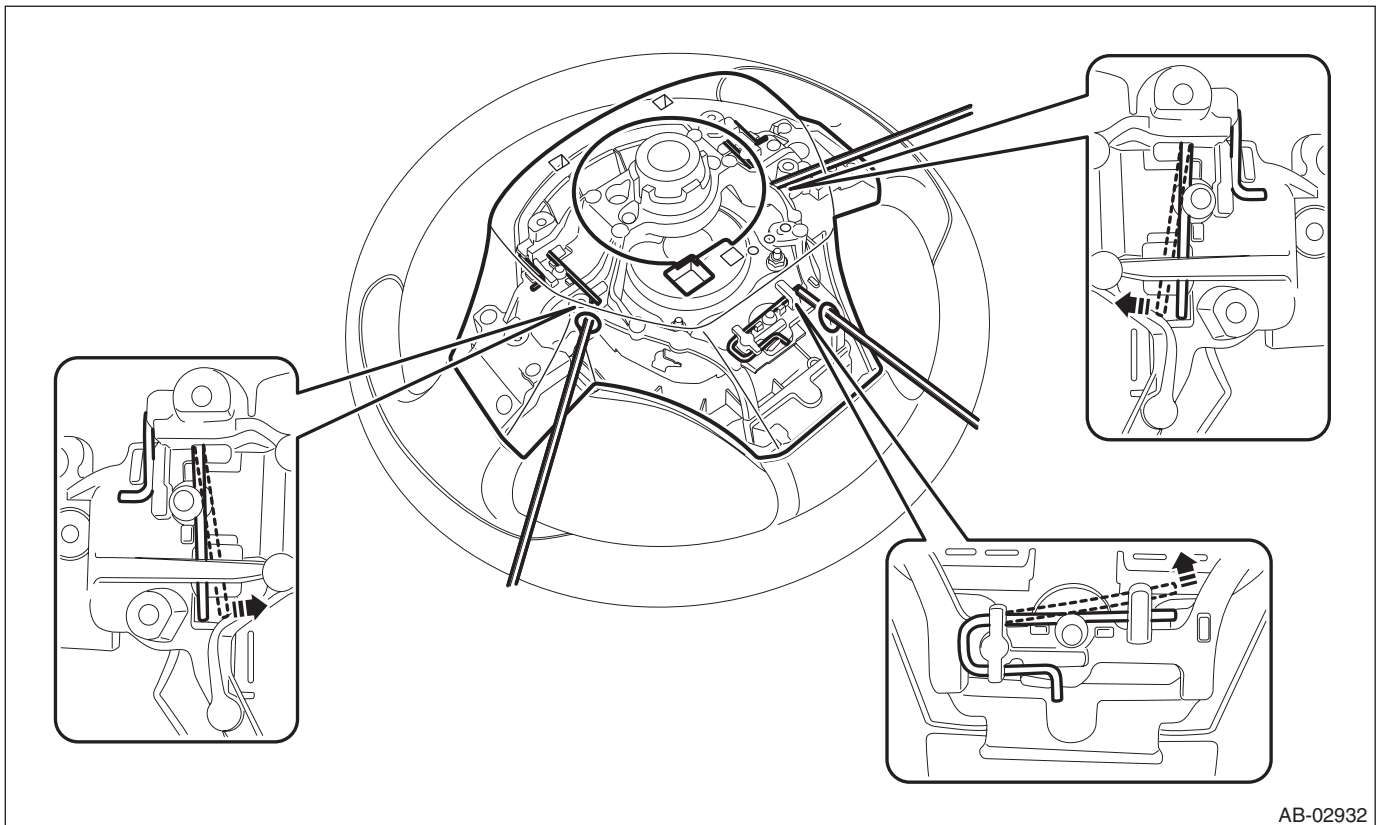

AB-02932

Steering Satellite Switch

ENTERTAINMENT

(2) Disconnect the horn harness and airbag connector and remove the airbag module assembly. <Ref. to AB-22, DRIVER'S AIRBAG MODULE, CURTAIN AIRBAG MODULE, PRETENSIONER & LAP SEAT BELT PRETENSIONER, PROCEDURE, Airbag Connector.>

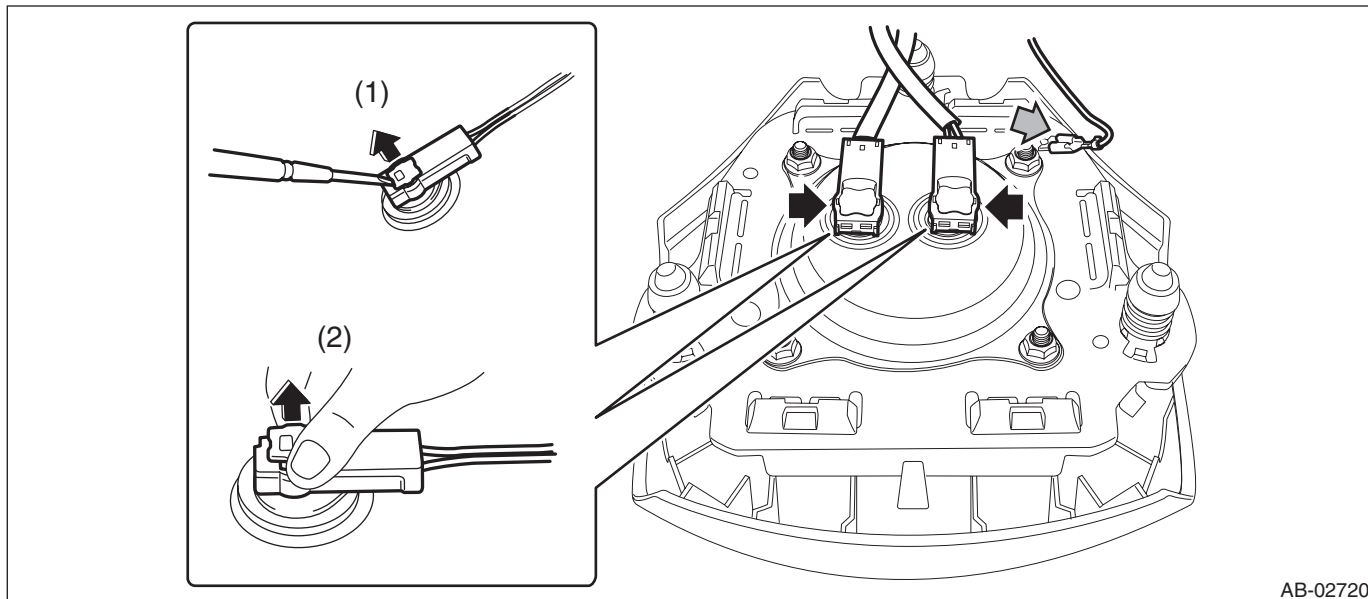

5) Remove the steering wheel.

CAUTION:

- Always use the steering wheel puller for removal to avoid deforming the steering wheel.
- If the steering wheel has been removed, make sure that the roll connector is not turned from the original position.

- (1) Disconnect the connector and remove the nut.
- (2) Put alignment marks, and remove the steering wheel using a steering wheel puller.

Preparation tool:

Steering wheel puller

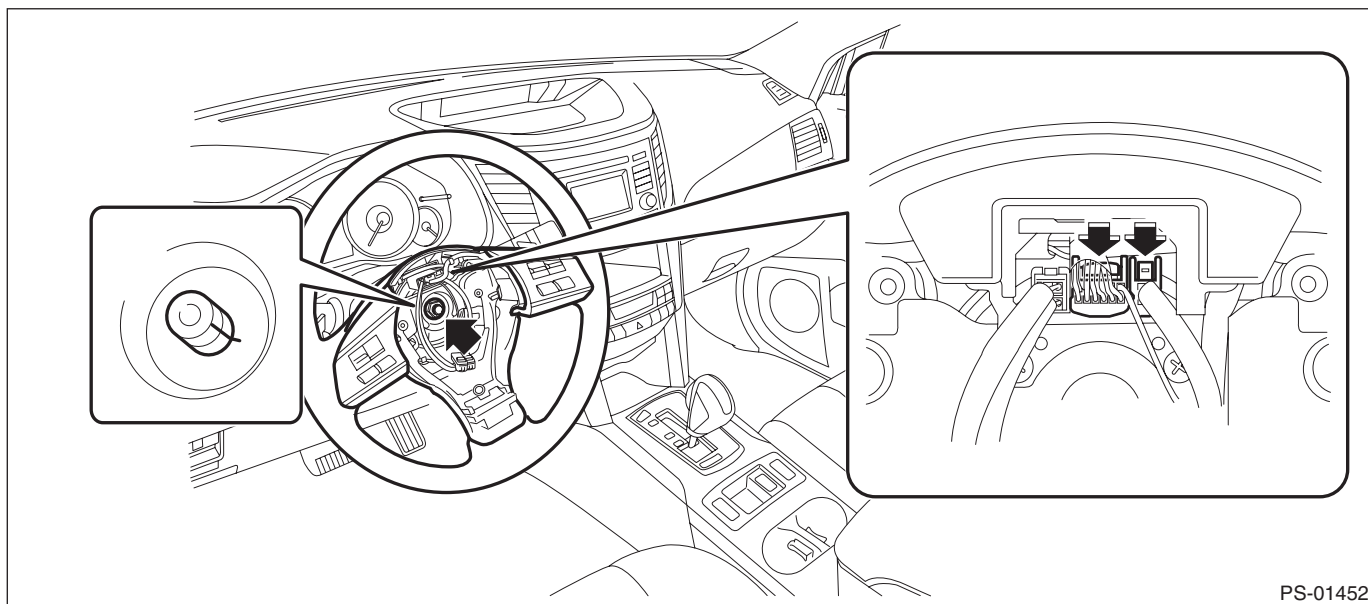

6) Remove the satellite switch.

(1) Remove the screw, disconnect the connector and remove the paddle shift switch. (Model with paddle shift)

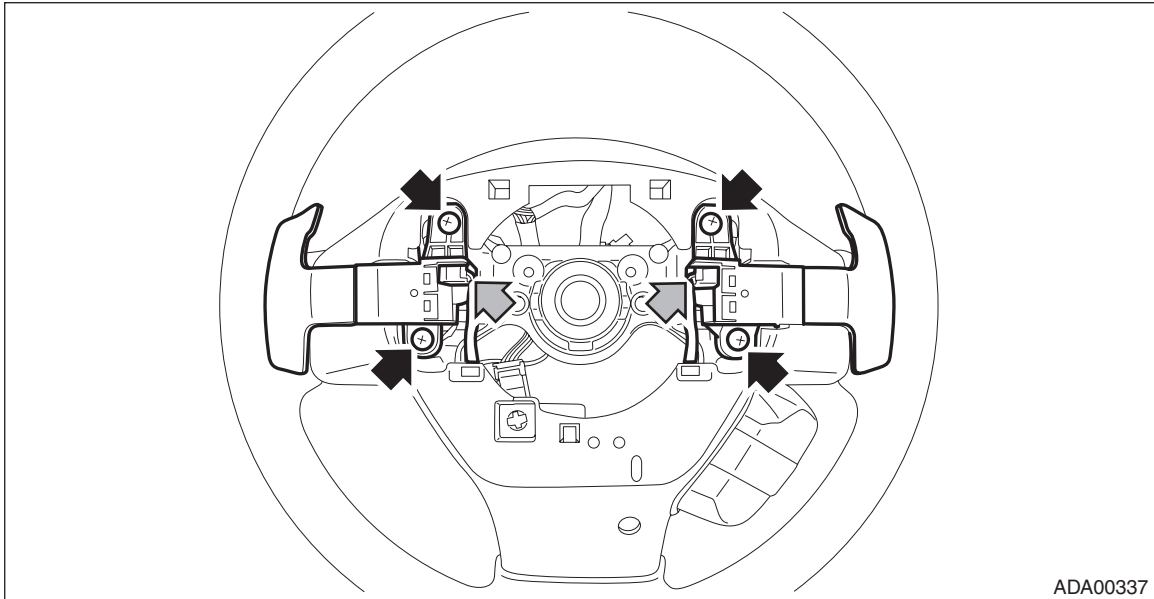

ADA00337

(2) Remove the steering switch connector and screw. (luminescent meter model)

(3) Release the claws and clips, detach the cover - steering wheel LWR.

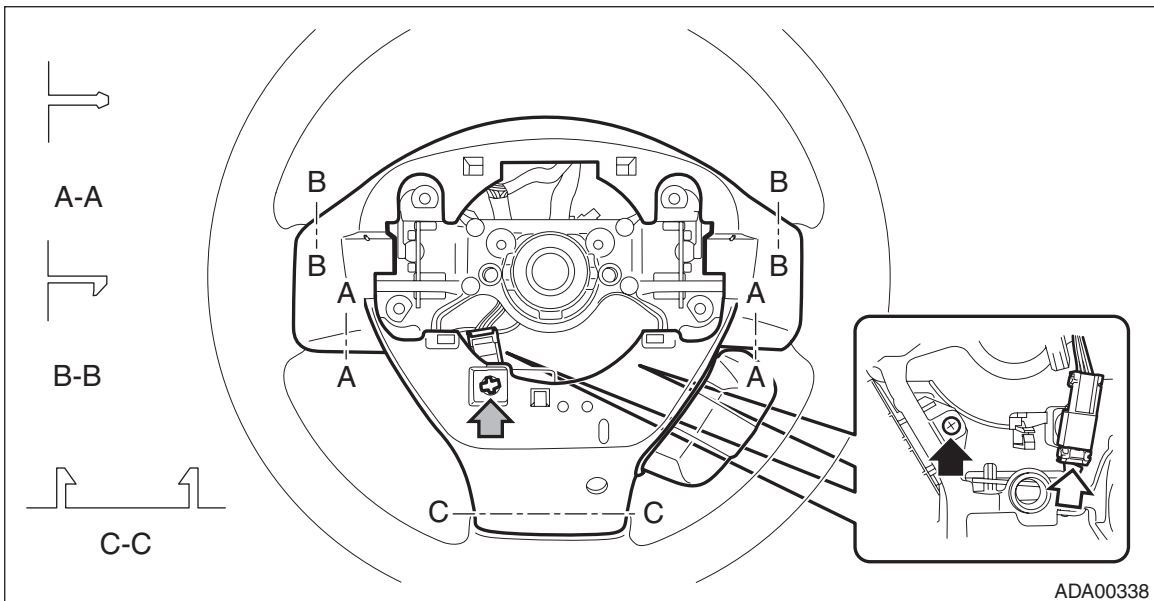

ADA00338

Steering Satellite Switch

ENTERTAINMENT

(4) Remove the screws and then remove the satellite switch assembly.

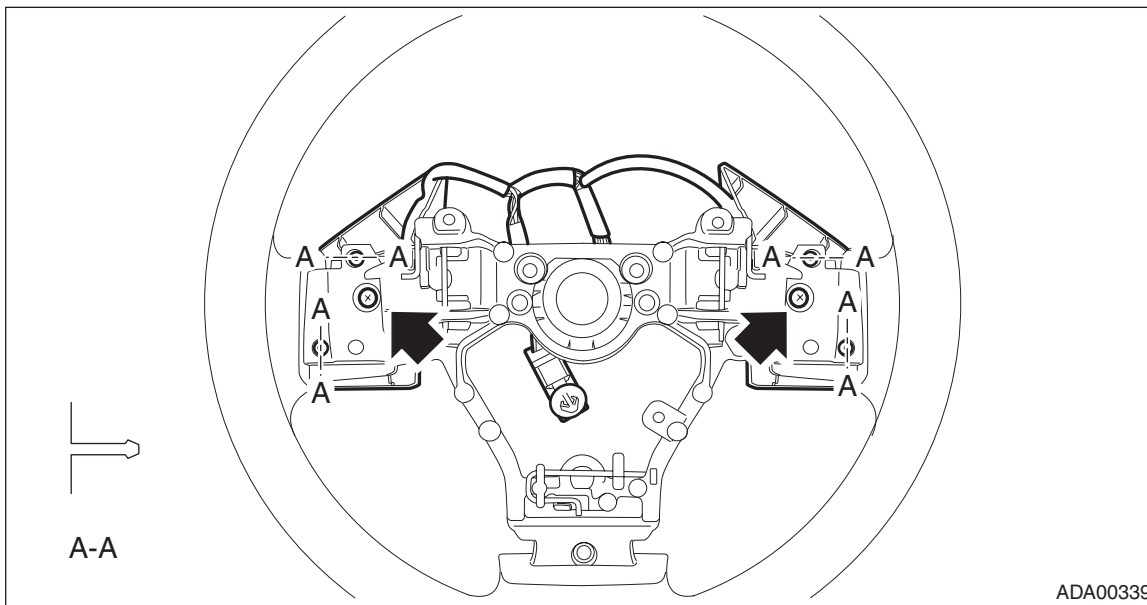

B: INSTALLATION

CAUTION:

- Before handling the airbag module, refer to “CAUTION” of “General Description” in “AIRBAG SYSTEM”. <Ref. to AB-10, CAUTION, General Description.>
- Do not allow harness and connectors to interfere or get tangled up with other parts.
- If the steering wheel and steering angle sensor (steering roll connector) are removed, adjust the steering angle sensor. <Ref. to VDC-20, ADJUSTMENT, VDC Control Module and Hydraulic Control Unit (VDCCM&H/U).>

1) Before installing steering wheel, be sure to adjust the direction of roll connector with steering. <Ref. to AB-109, ADJUSTMENT, Roll Connector.>

2) Install each part in the reverse order of removal.

NOTE:

Align the alignment marks on the steering wheel and steering column.

Tightening torque:

Steering wheel: 39 N·m (3.98 kgf·m, 28.8 ft·lb)

Clearance:

Between column cover and steering wheel: 4 — 6 mm (0.16 — 0.24 in)

C: INSPECTION

1. SATELLITE SWITCH

1) Measure the resistance between satellite switch connector terminals during switch operation.

- TYPE 1

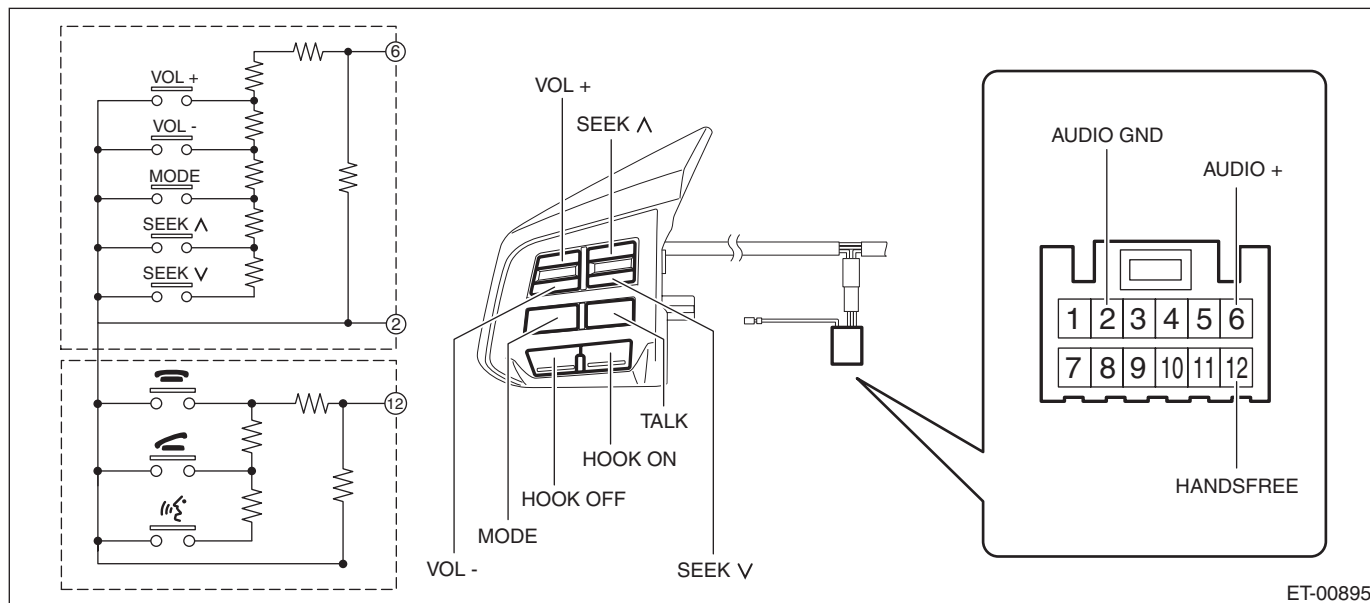

Switch	Switch operation	Terminal No.	Standard
VOL (+) VOL (-) MODE SEEK (^) SEEK (v)	All OFF	6 and 2	Approx. 4,700 Ω
VOL (+)	ON	6 and 2	Approx. 90 Ω
VOL (-)	ON	6 and 2	Approx. 192 Ω
MODE	ON	6 and 2	Approx. 334 Ω
Preset CH UP/SEEK (^)	ON	6 and 2	Approx. 602 Ω
Preset CH DOWN/SEEK (v)	ON	6 and 2	Approx. 1,143 Ω

Switch	Switch operation	Terminal No.	Standard
HOOK ON HOOK OFF TALK	All OFF	12 and 2	Approx. 100 kΩ
HOOK ON	ON	12 and 2	Approx. 329 Ω
HOOK OFF	ON	12 and 2	Approx. 1,000 Ω
TALK	ON	12 and 2	Approx. 3,110 Ω

Replace the satellite switch if the inspection result is not within the standard value.

Steering Satellite Switch

ENTERTAINMENT

• TYPE 2

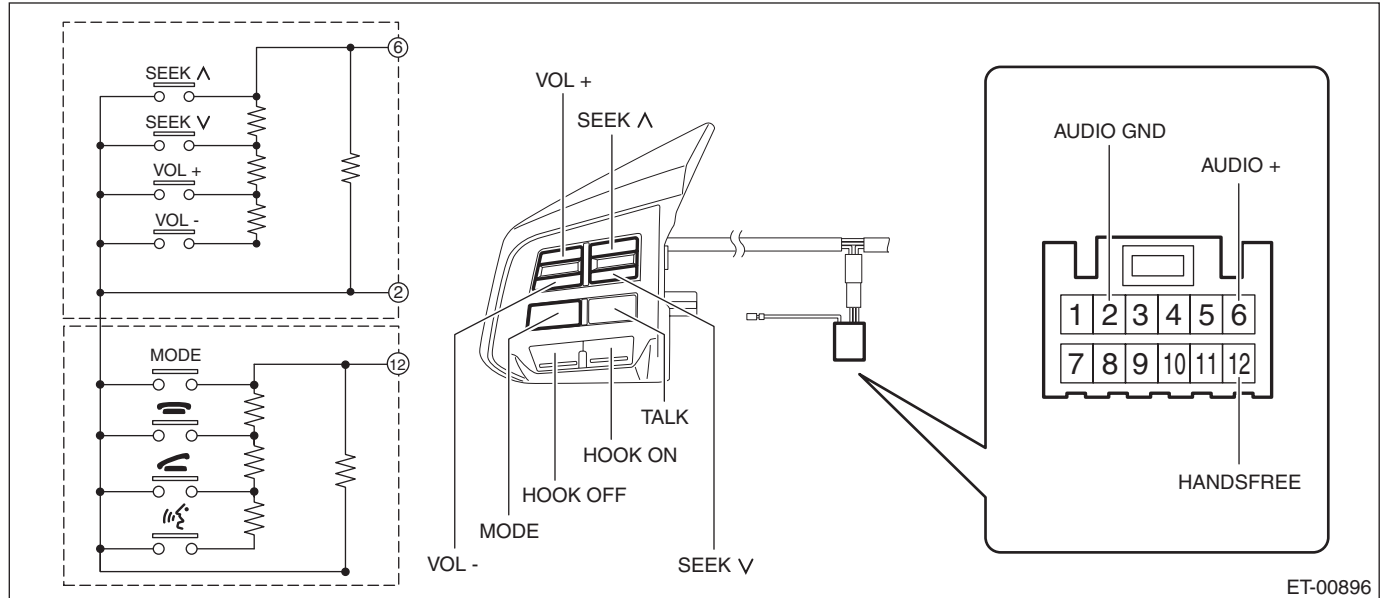

Switch	Switch operation	Terminal No.	Standard
SEEK (\wedge) SEEK (\vee) VOL (+) VOL (-)	All OFF	6 and 2	Approx. 100 k Ω
Preset CH UP/SEEK (\wedge)	ON	6 and 2	Approx. less than 1 Ω
Preset CH DOWN/SEEK (\vee)	ON	6 and 2	Approx. 330 Ω
VOL (+)	ON	6 and 2	Approx. 1,000 Ω
VOL (-)	ON	6 and 2	Approx. 3,110 Ω

Switch	Switch operation	Terminal No.	Standard
MODE HOOK ON HOOK OFF TALK	All OFF	12 and 2	Approx. 100 k Ω
MODE	ON	12 and 2	Approx. less than 1 Ω
HOOK ON	ON	12 and 2	Approx. 330 Ω
HOOK OFF	ON	12 and 2	Approx. 1,000 Ω
TALK	ON	12 and 2	Approx. 3,110 Ω

Replace the satellite switch if the inspection result is not within the standard value.

2) Check the satellite switch illumination.

(1) Connect the battery (12 V) to the satellite switch connector.

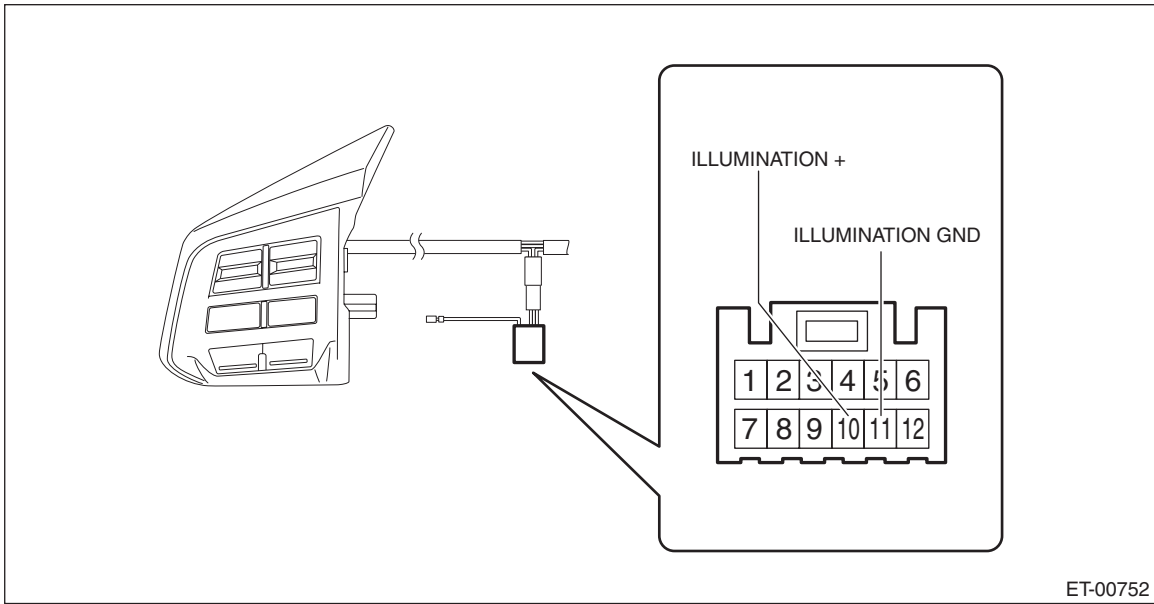

(2) If illumination does not turn on, replace the satellite switch assembly.

Steering Satellite Switch

ENTERTAINMENT

2. STEERING ROLL CONNECTOR

CAUTION:

- Do not rotate the roll connector to more than the specified number of turns. Otherwise, the roll connector internal wire may be broken.
- When determining the end stop, rotate the connector slowly without applying excessive force. Applying excessive force at the end stop may break the internal wire.

1) Adjust the roll connector. <Ref. to AB-109, ADJUSTMENT, Roll Connector.>

2) Set the roll connector to the central position.

3) Check the resistance between each connector under the following conditions:

- Measure the resistance with the roll connector at the center position (the front wheels in straight-ahead position).
- Turn the roll connector counterclockwise from the center position (with the front wheels in straight-ahead position) until it stops, and then measure the resistance while turning the connector clockwise by approximately 2.5 turns.

Preparation tool:

Circuit tester

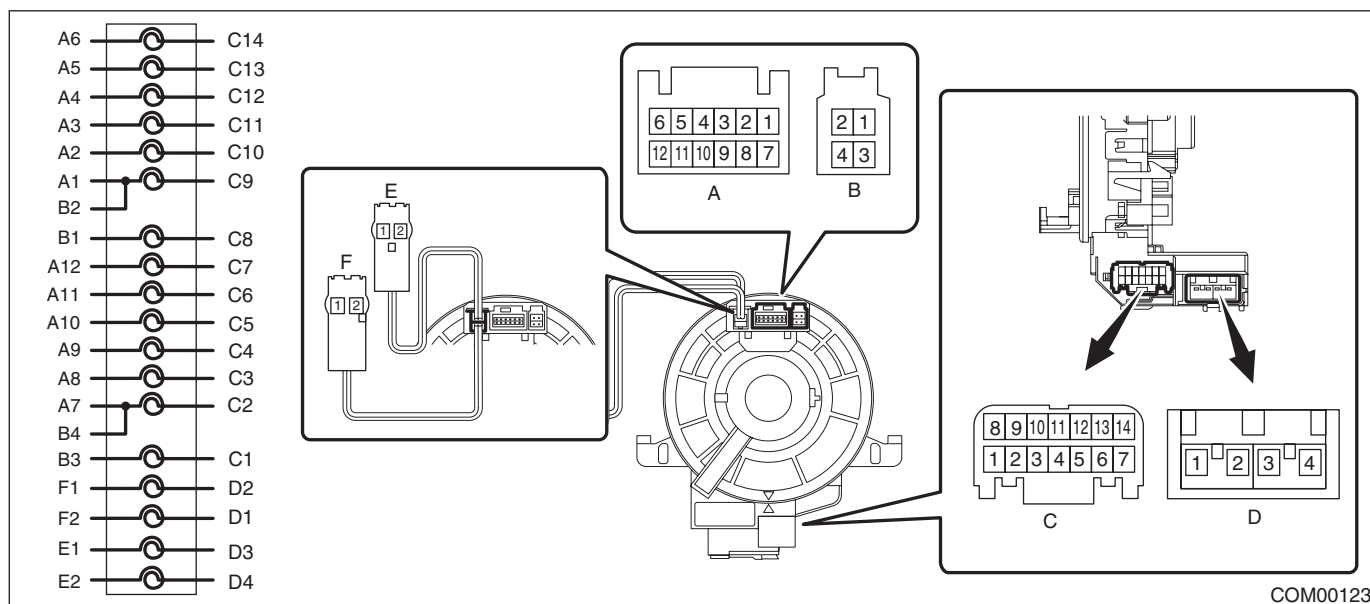

Terminal No.	Inspection conditions	Standard
A6 — C14	Always	Less than 1 Ω
A12 — C7	Always	Less than 1 Ω
A11 — C6	Always	Less than 1 Ω
A10 — C5	Always	Less than 1 Ω
A9 — C4	Always	Less than 1 Ω

4) Replace the roll connector with a new part if the inspection result is not within the standard value.