

7. Rear Sealing Cover

A: REMOVAL

- 1) Disconnect the ground cable from battery.
- 2) Remove the door trim assembly.
 - (1) Open the cover and remove the screw.
 - (2) Remove the clips in the order of (A) to (H) and remove the door trim assembly from the door panel.

CAUTION:

When removing the door trim, be sure to remove the clips in the correct order. Forcibly removing clips may damage the door panel assembly.

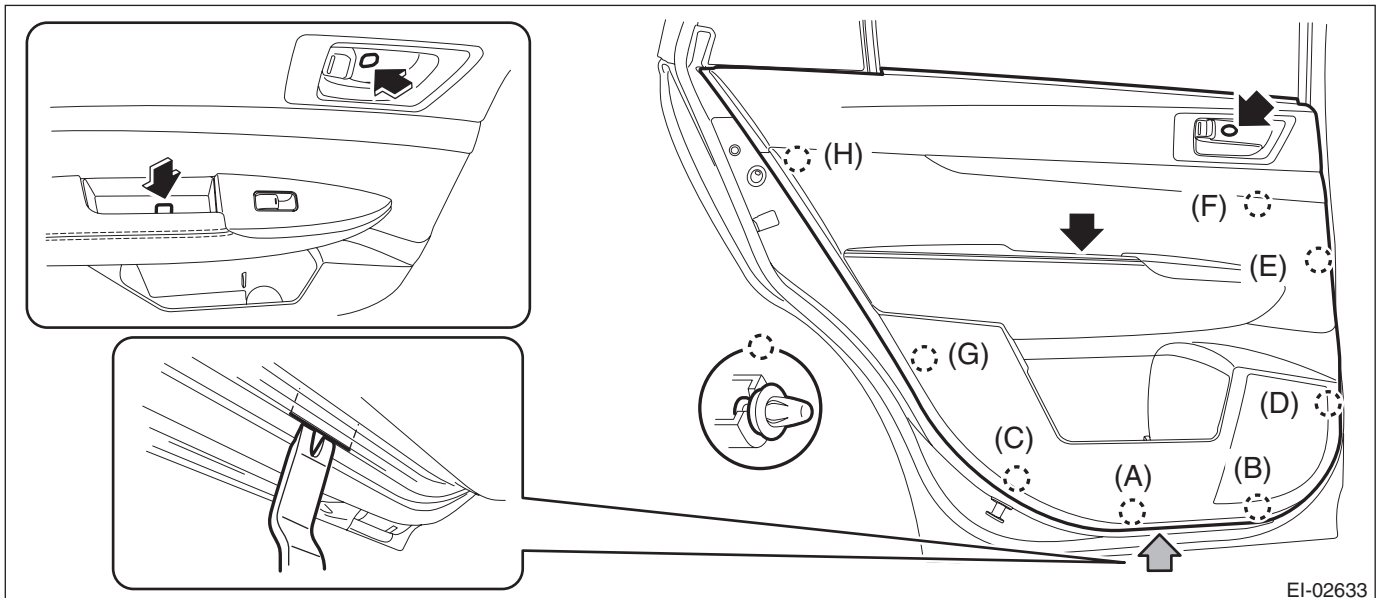

NOTE:

Insert a plastic clip remover into the slit at the bottom of the door trim, to lift the door trim.

- (3) Remove the cables (a) and (b) from the cable holder of inner remote.

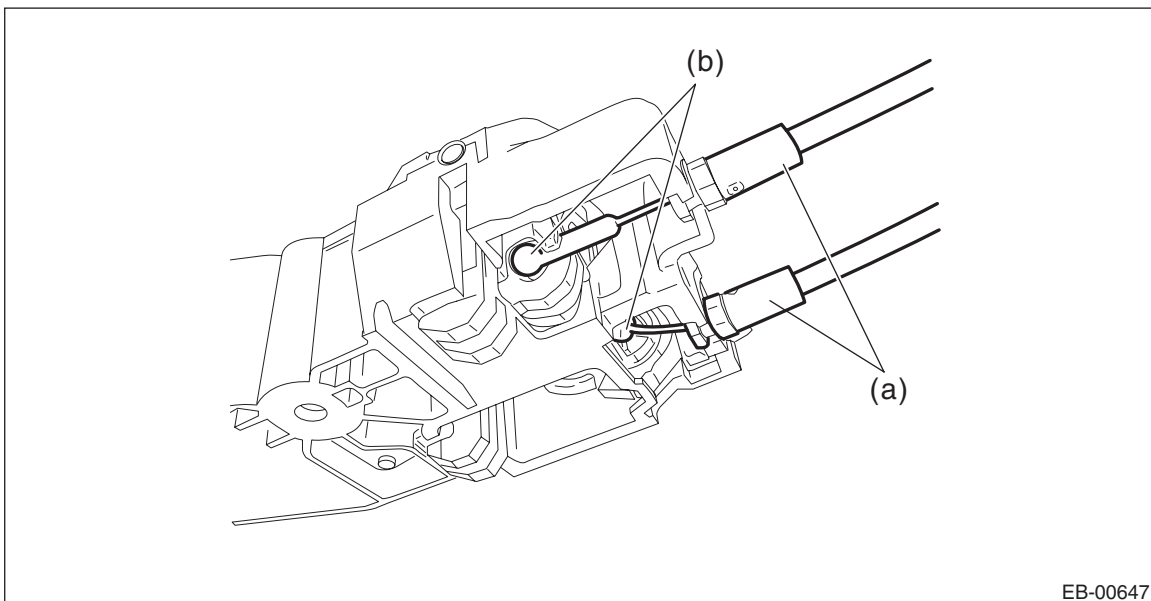

- (4) Disconnect the harness connector and remove the door trim.

Rear Sealing Cover

EXTERIOR BODY PANELS

3) Remove the sealing cover.

CAUTION:

- Carefully remove the butyl tape. Excessive force will easily break the cover.
- If the sealing cover gets broken, replace it with a new part.
 - (1) Remove the screw to remove the door trim bracket.
 - (2) Carefully remove the butyl tape to remove the sealing cover.

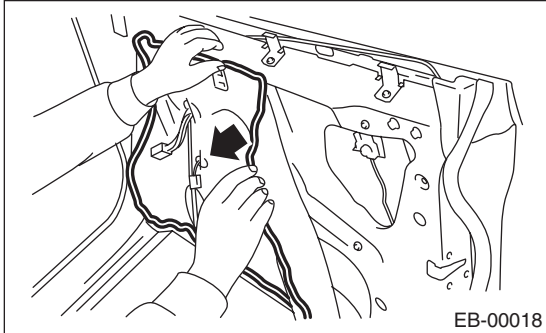

B: INSTALLATION

CAUTION:

- If the sealing cover gets broken, replace it with a new part.
 - Apply a butyl tape evenly.
 - Attach the sealing cover, keeping it from becoming wrinkled.
 - Breaks in the bead will allow water leakage and contamination.
- 1) Install each part in the reverse order of removal.
 - 2) When replacing the sealing cover, use the butyl tape.
 - 3) Press the butyl tape-applied area firmly to prevent any floating on surface.

Butyl tape:

3M8626 or equivalent

C: INSPECTION

If the sealing cover gets damaged, replace it with a new part.