

6. Subaru Select Monitor

A: OPERATION

1. GENERAL DESCRIPTION

For on-board diagnosis function of the EyeSight, use the Subaru Select Monitor.

The on-board diagnosis function operates in three categories, which are used depending on the type of problems;

1) Diagnosis with diagnostic trouble code (DTC):

When the electrical failure occurs in the EyeSight, DTC is detected from the stereo camera. If the DTC is detected, the relevant DTC is displayed by illuminating or blinking the EyeSight warning light. To check the details concerning the DTC, use the Subaru Select Monitor.

2) Diagnosis with cancel code:

(1) This category of diagnosis requires actual vehicle driving in order to determine the cause, as when cruise speed is cancelled during driving although cruise cancel condition is not entered.

(2) Cruise control memory in ECM and stereo camera stores the cancel condition (Code No.) which occurred during driving. When there are multiple cancel conditions (Code No.), they are shown on the Subaru Select Monitor.

CAUTION:

- **In the cruise control memory, not only the cruise control “cancel” occurred (although the “cancel” operation is not entered by the driver), but also the “cancel” condition input by the driver is stored.**

- **The latest memory content (latest code) is cleared when ignition switch is turned to OFF. However, memory contents set by the diagnosis of faulty switches related to the system and cruise control will remain as trouble history (memory code) after the ignition switch is turned to OFF.**

3) Real-time Diagnosis:

Real-time diagnosis function is used to determine whether or not the input signal system is in good order, according to signal emitted from switches, sensors, etc.

(1) Vehicle cannot be driven at cruise speed when the problem occurs in the cruise control system or relevant circuits.

(2) Monitor the signal conditions from switches and sensors.

2. BASIC OPERATION

For operation procedures, refer to the “PC application help for Subaru Select Monitor”.

Subaru Select Monitor

EyeSight (DIAGNOSTICS)

B: INSPECTION

1. COMMUNICATION FOR INITIALIZING IMPOSSIBLE

- Communication error with stereo camera

DETECTING CONDITION:

- Defective harness connector
- Power supply circuit malfunction
- Defective stereo camera
- Defective CAN system
- Defective Subaru Select Monitor

TROUBLE SYMPTOM:

- EyeSight warning light blinks.

WIRING DIAGRAM:

EyeSight System <Ref. to WI-182, WIRING DIAGRAM, EyeSight System.>

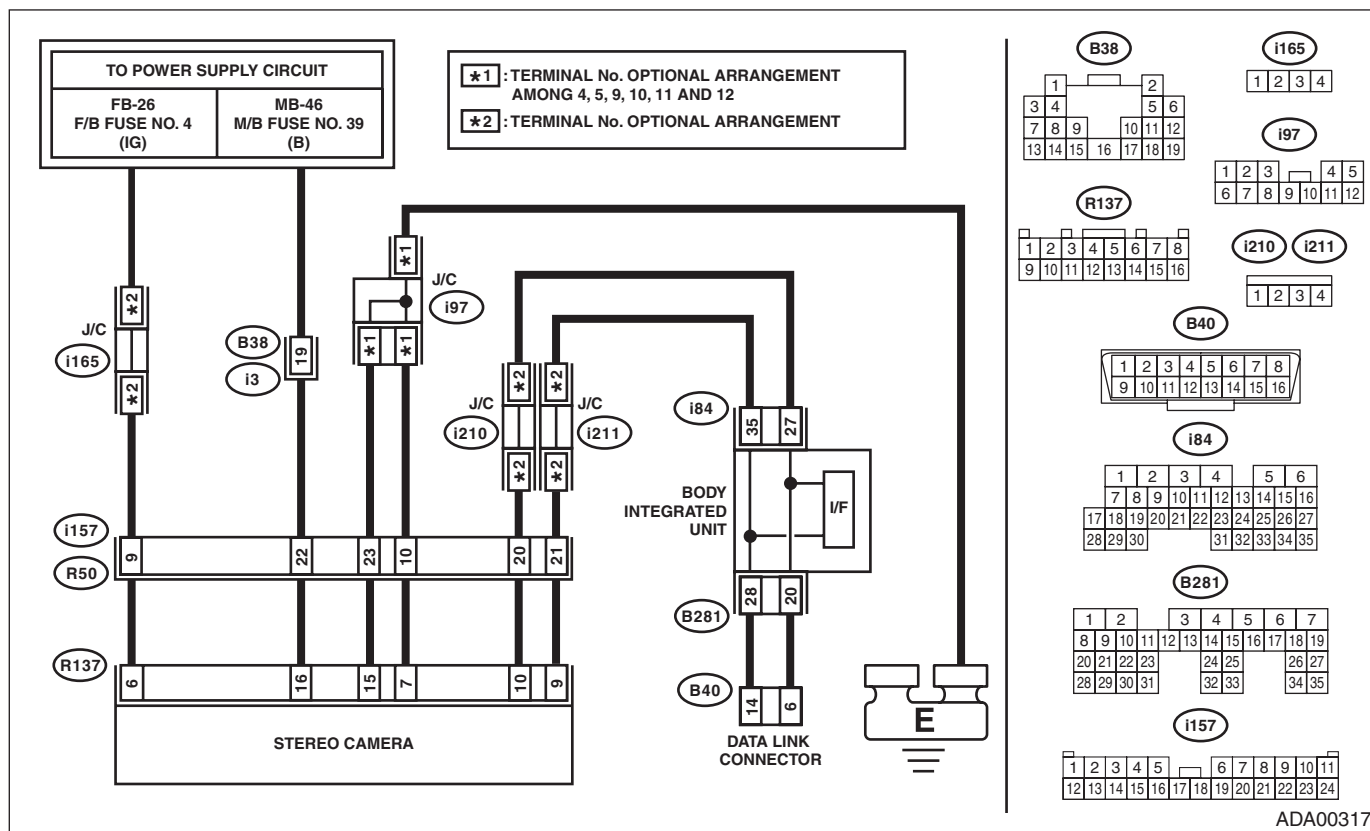

ADA00317

Step	Check	Yes	No
1	CHECK IGNITION SWITCH.	Is the ignition switch ON?	Go to step 2.
2	CHECK BATTERY. 1) Turn the ignition switch to OFF. 2) Measure the battery voltage.	Is the voltage 10 V or more?	Go to step 3.
3	CHECK BATTERY TERMINAL.	Is the battery terminal contact proper?	Go to step 4.
			Turn the ignition switch to ON, and select {ADA adaptive cruise control system} using the Subaru Select Monitor.
			Charge or replace the battery.
			Connect the battery terminal securely or replace it.

Subaru Select Monitor

EyeSight (DIAGNOSTICS)

Step	Check	Yes	No
4 CHECK SUBARU SELECT MONITOR COMMUNICATION. 1) Turn the ignition switch to ON. 2) Using the Subaru Select Monitor, check whether the communication can be executed normally.	Is the communication between Subaru Select Monitor and other unit normal?	Go to step 5.	Check the connection of Subaru Select Monitor.
5 READ DTC OF BODY INTEGRATED UNIT. Select {Integ. unit mode}, and check DTC.	Is there any fault?	Repair according to diagnosis for LAN system.	Go to step 6.
6 CHECK HARNESS CONNECTOR BETWEEN STEREO CAMERA AND DATA LINK CONNECTOR. 1) Turn the ignition switch to OFF. 2) Disconnect the stereo camera connector. 3) Measure the resistance between the stereo camera and the data link connector. Connector & terminal (R137) No. 10 — (B40) No. 6: (R137) No. 9 — (B40) No. 14:	Is the resistance less than 10 Ω ?	Go to step 7.	Repair or replace the harness and connectors between the stereo camera and data link connector.
7 CHECK POWER SUPPLY CIRCUIT. 1) Turn the ignition switch to ON. 2) Measure the voltage between stereo camera and chassis ground. Connector & terminal (R137) No. 6 (+) — Chassis ground (-):	Is the voltage 10 V or more?	Go to step 8.	Check the harness from battery to stereo camera.
8 CHECK GROUND CIRCUIT. 1) Turn the ignition switch to OFF, then disconnect the ground cable from battery. 2) Measure the resistance between harness connector of stereo camera and chassis ground. Connector & terminal (R137) No. 7 — Chassis ground: (R137) No. 15 — Chassis ground:	Is the resistance less than 10 Ω ?	Go to step 9.	Check the harness from stereo camera to chassis ground.
9 CHECK CONNECTOR.	Is there poor contact of stereo camera connector?	Repair the connector, or replace harness.	Replace the stereo camera. <Ref. to ES-8, REMOVAL, Stereo Camera.>