

# Power Window Control Switch

GLASS/WINDOWS/MIRRORS

## 4. Power Window Control Switch

### A: REMOVAL

#### 1. MAIN SWITCH

- 1) Remove the front door trim. <Ref. to EI-59, FRONT DOOR, REMOVAL, Door Trim.>
- 2) Remove the power window switch panel.

#### CAUTION:

**Do not damage the door trim with the switch panel.**

- (1) Insert a sheet of protective paper (a) between switch panel and door trim.
- (2) Remove the screws and disconnect the connector.
- (3) Disconnect the claws and then remove the power window switch panel.

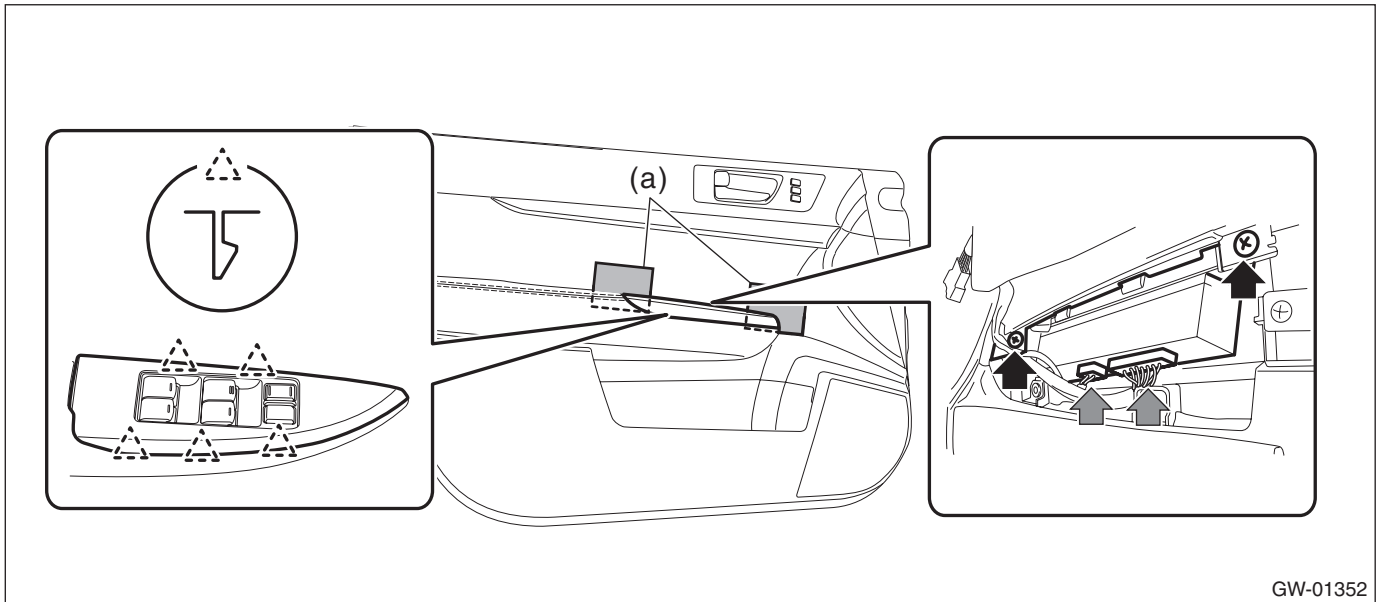

- (4) Remove the screws and remove the power window main switch.

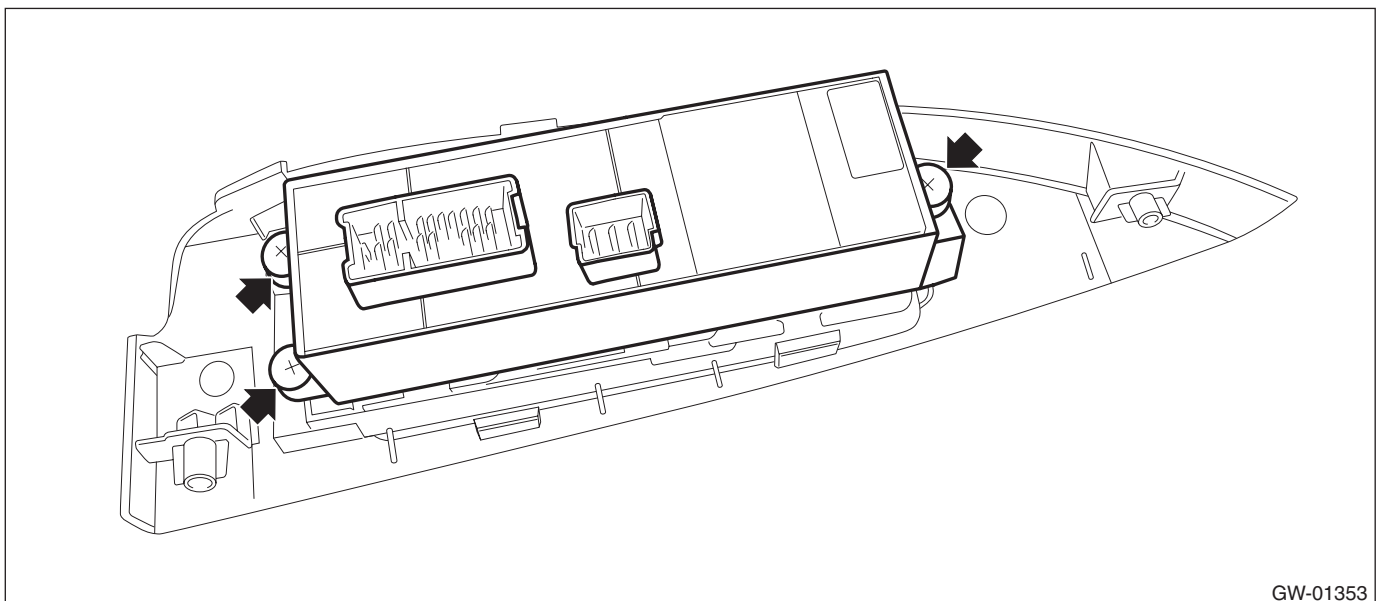

#### 2. SUB-SWITCH

- 1) Remove the rear door trim. <Ref. to EI-60, REAR DOOR, REMOVAL, Door Trim.>

2) Remove the power window switch panel.

**CAUTION:**

**Do not damage the door trim with the switch panel.**

- (1) Insert a sheet of protective paper (a) between switch panel and door trim.
- (2) Remove the screws and disconnect the connector.
- (3) Disconnect the claws and then remove the power window switch panel.

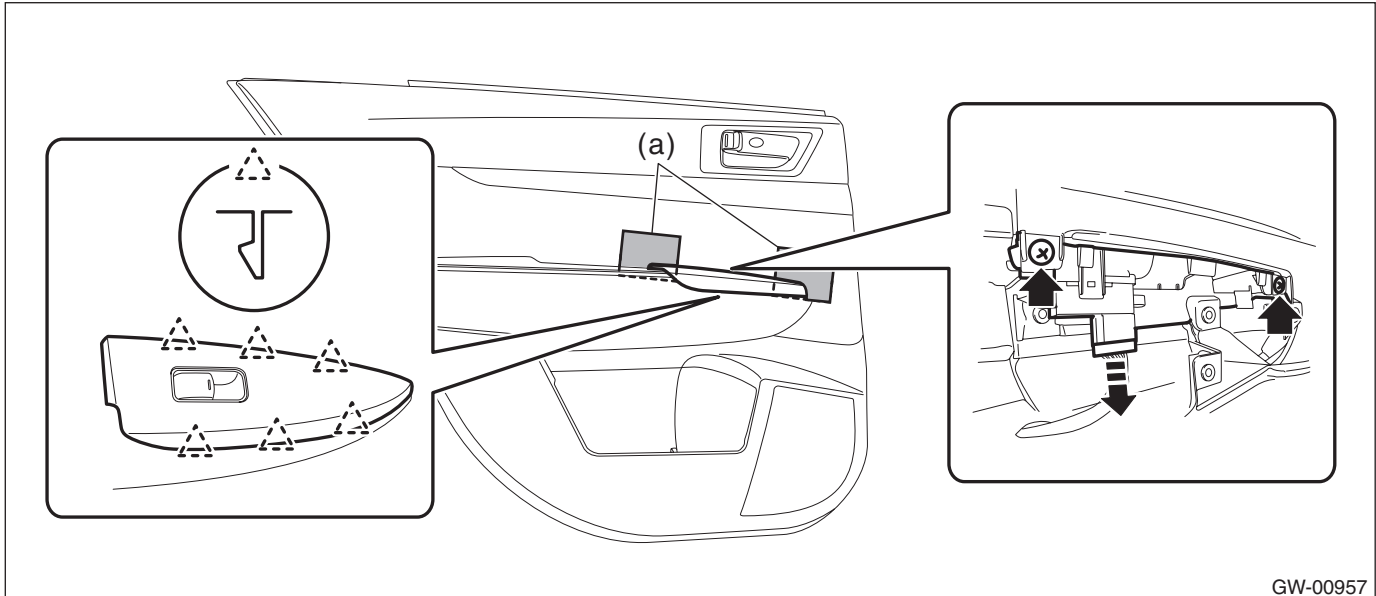

3) Disconnect the claws and then remove the power window sub-switch.

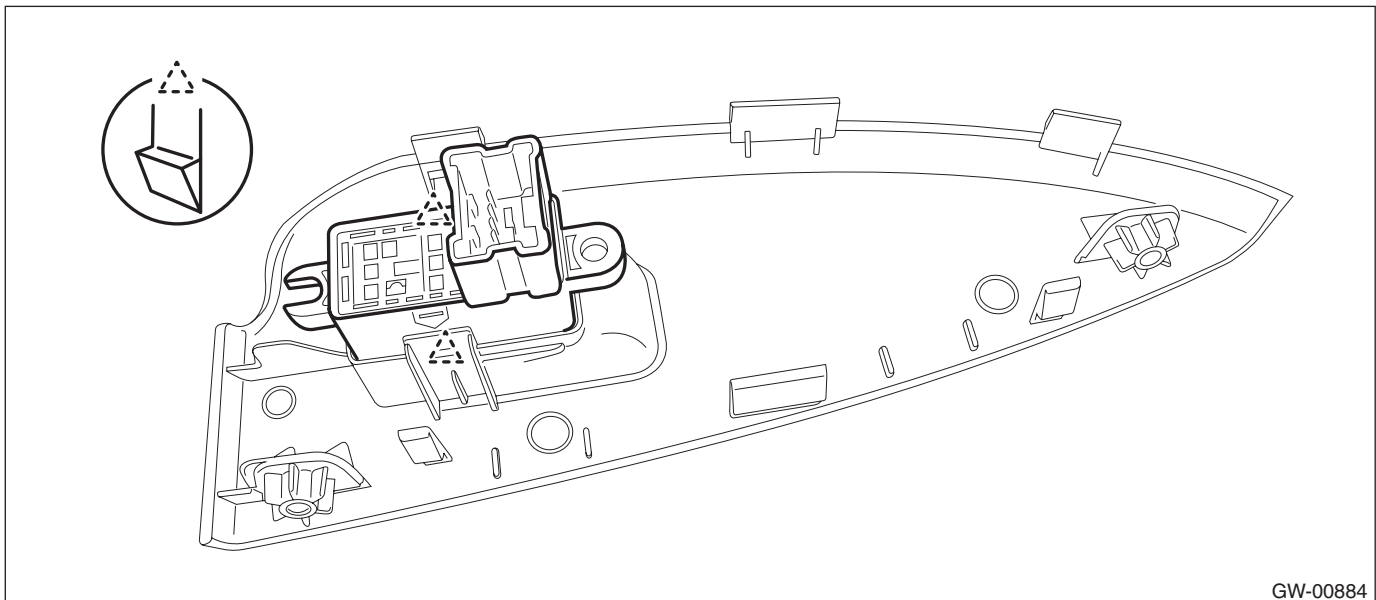

## B: INSTALLATION

**CAUTION:**

• After installation of main switch, always perform the initial setting. (model with driver's side AUTO UP function)

Failure to do so may cause the improper activation of auto-reverse operation for pinching hazard prevention.

• Use protective paper to avoid damage to the door trim.

- 1) Install each part in the reverse order of removal.
- 2) Perform initial setting operation (reset operation A). <Ref. to GW-10, RESET OPERATION A, OPERATION, Power Window System.>

# Power Window Control Switch

GLASS/WINDOWS/MIRRORS

## C: INSPECTION

### 1. MAIN SWITCH

- Driver's seat

#### CAUTION:

Since the driver's side power window switch is controlled by CPU, do not check continuity for switch alone with the circuit tester. Performing continuity check with circuit tester may damage the driver's side power window switch circuit.

Check output from the power window main switch to driver's side motor using the oscilloscope function in the Subaru Select Monitor.

- 1) Remove the power window main switch.
- 2) Connect the battery and the Subaru Select Monitor to the power window main switch terminal.

#### CAUTION:

Never mix up the terminals when connecting the power window main switch connector and battery. If connected to a wrong terminal, the power window main switch may be damaged.

#### NOTE:

- When the battery is connected to the power window main switch terminal, the mark on the switch knob illuminates.
- For detailed procedures, refer to "Subaru Select Monitor Operation Manual".

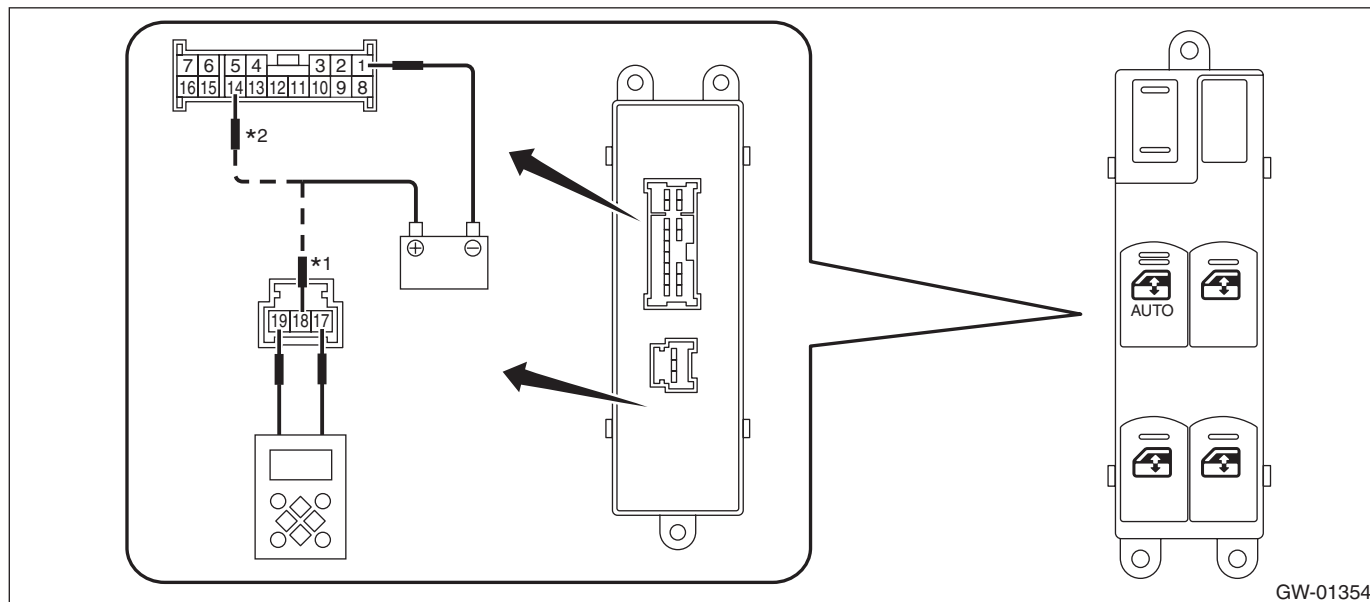

\*1: Model with driver's side AUTO UP function

\*2: Model without driver's side AUTO UP function

- 3) Operate the main switch and check the output.

#### NOTE:

Since output time during window UP operation is extremely short, it cannot be checked without using a measuring instrument such as oscilloscope. Output is constantly produced while the switch is operated for window DOWN operation.

Inspection conditions	Output time (model without driver's side AUTO UP function)	Output time (model with driver's side AUTO UP function)	Standard
AUTO UP	600 ms	Approx. 130 ms	Battery voltage
UP	During switch operation		
OFF	—	—	0 V
DOWN	During switch operation	During switch operation	Battery voltage
AUTO DOWN	600 ms	Approx. 300 ms	

# Power Window Control Switch

4) Replace the power window main switch if the inspection result is not within the standard value.

• **Except for driver's seat**

1) Check the resistance between main switch terminals.

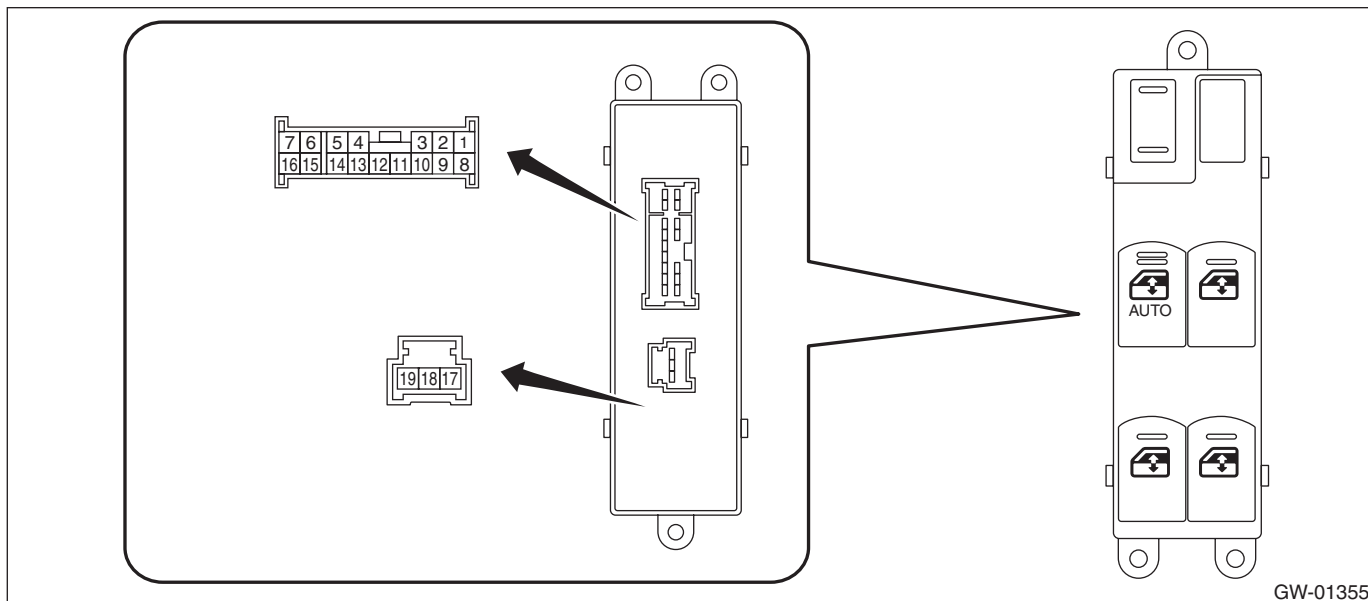

	Terminal No.	Inspection conditions	Standard
Passenger's seat	14 — 8 2 — 1	UP	Less than 1 Ω
	14 — 2 14 — 8	OFF	1 MΩ or more
	1 — 2 1 — 8 2 — 8		Less than 1 Ω
	14 — 2 1 — 8	DOWN	Less than 1 Ω
Rear LH	14 — 15 1 — 16	UP	Less than 1 Ω
	14 — 15 14 — 16	OFF	1 MΩ or more
	1 — 15 1 — 16 15 — 16		Less than 1 Ω
	14 — 16 1 — 15	DOWN	Less than 1 Ω
Rear RH	14 — 6 1 — 6	UP	Less than 1 Ω
	14 — 6 14 — 7	OFF	1 MΩ or more
	1 — 6 1 — 7 6 — 7		Less than 1 Ω
	14 — 6 7 — 1	DOWN	Less than 1 Ω

2) Replace the main switch if the inspection result is not within the standard value.

# Power Window Control Switch

GLASS/WINDOWS/MIRRORS

## 2. SUB-SWITCH

- 1) Remove the sub-switch.
- 2) Check the resistance between sub-switch terminals.

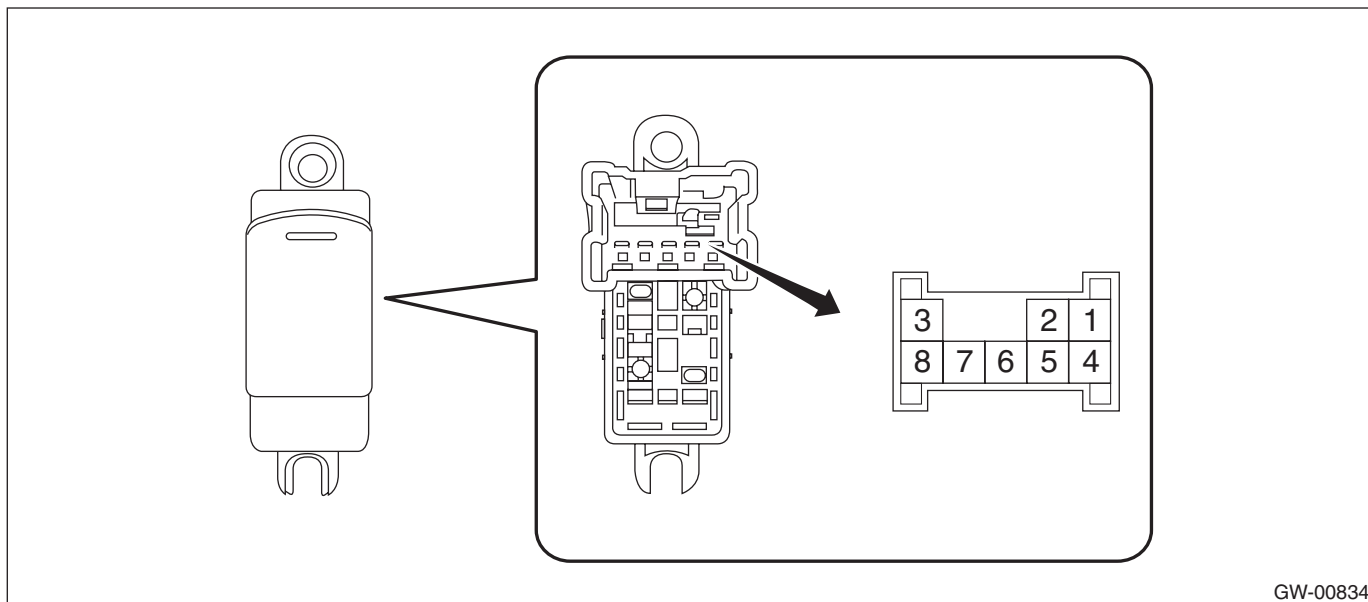

GW-00834

	Terminal No.	Inspection conditions	Standard
Passenger seat, rear	4 — 5 6 — 7	OFF	Less than 1 Ω
	5 — 6 6 — 8		1 MΩ or more
	5 — 6 6 — 7	UP	Less than 1 Ω
	4 — 5 4 — 8		1 MΩ or more
	6 — 7 6 — 8	DOWN	Less than 1 Ω
	4 — 6 7 — 8		1 MΩ or more

# Power Window Control Switch

3) Check the switch light illumination condition.

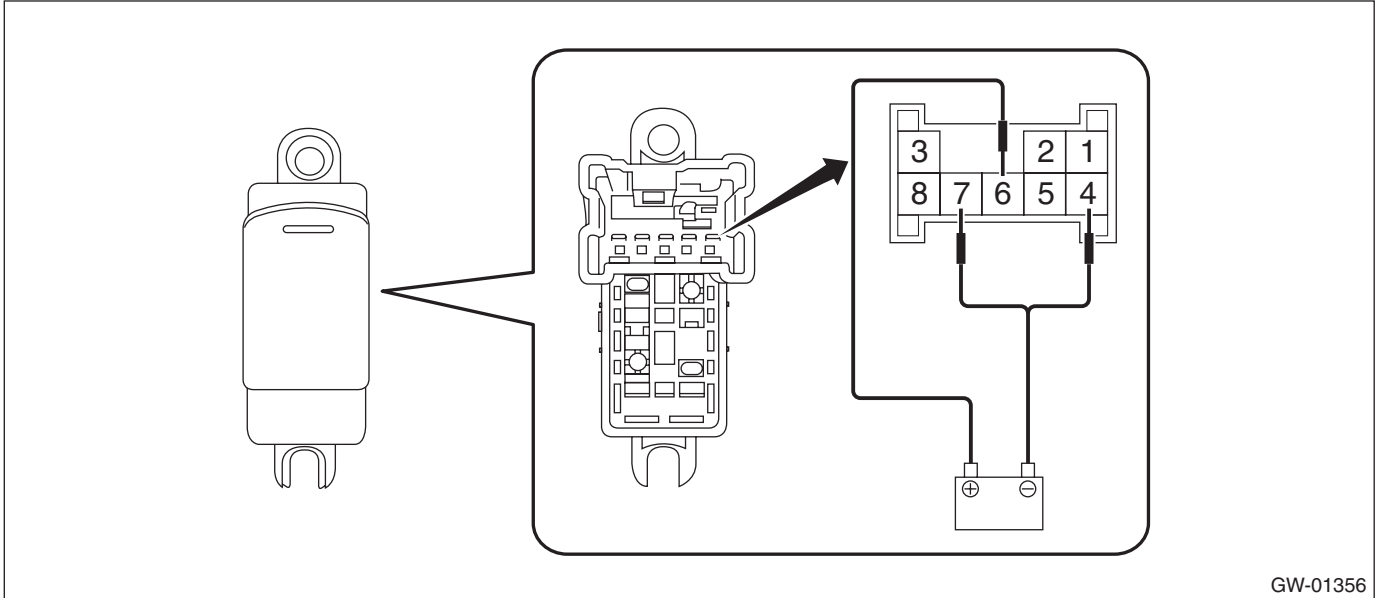

	Terminal No.	Inspection conditions	Specification
Passenger seat, rear	6 — 7, 4	Battery connection between terminals	Light ON

4) Replace the sub-switch if the inspection result is not within the standard value.