

11. Combination Switch (Light)

A: REMOVAL

- 1) Position the front wheels straight ahead. (After moving a vehicle 5 m (16 ft) or more with front wheels positioned straight ahead, make sure that the vehicle moves straight ahead.)
- 2) Turn the ignition switch to OFF.
- 3) Disconnect the ground cable from battery and wait for at least 60 seconds before starting work.
- 4) Remove the driver's airbag module assembly.

CAUTION:

Before handling the airbag module, refer to "CAUTION" of "General Description" in "AIRBAG SYSTEM". <Ref. to AB-10, CAUTION, General Description.>

- (1) Using a hexagon wrench etc. wrapped by protective tape, insert the snap pins and release the locks (3 locations).

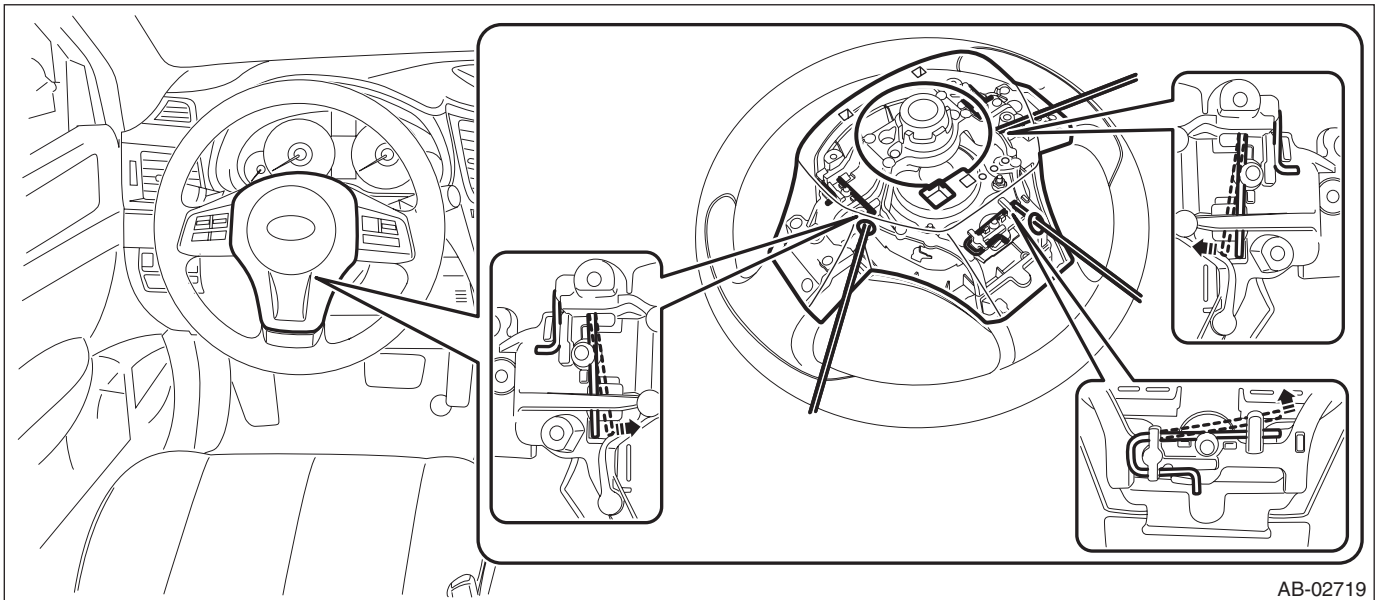

AB-02719

- (2) Disconnect the horn harness and airbag connector and remove the airbag module assembly. <Ref. to AB-19, PROCEDURE, Airbag Connector.>

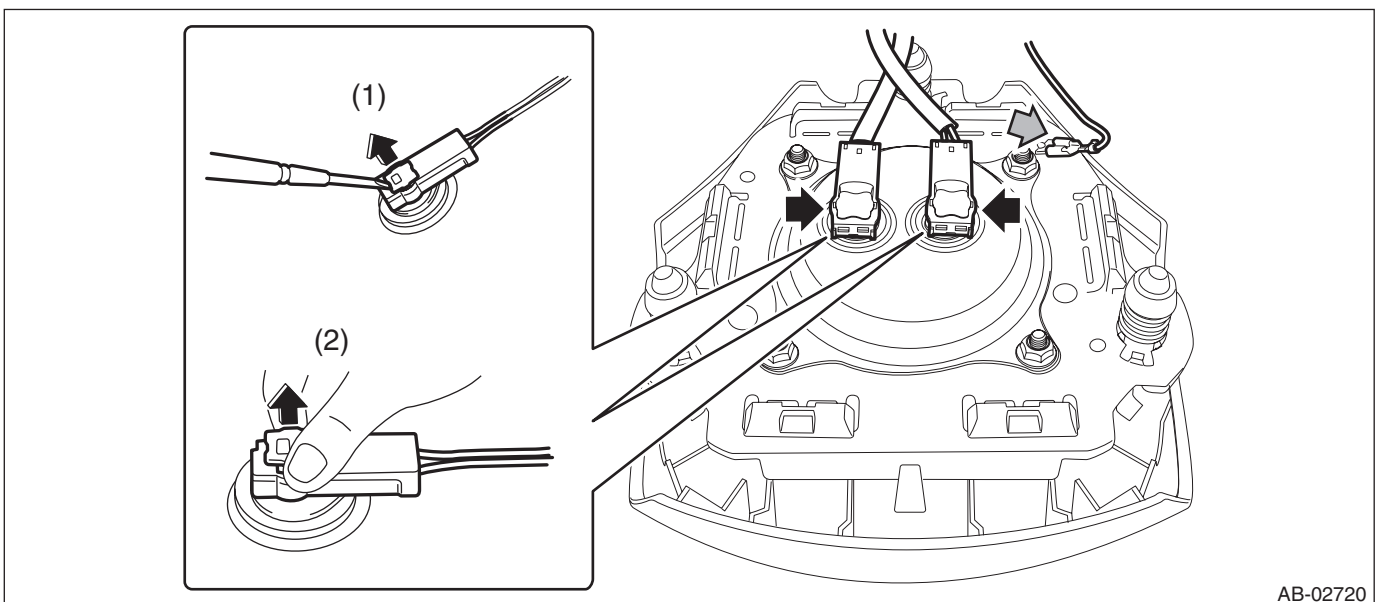

AB-02720

Combination Switch (Light)

LIGHTING SYSTEM

5) Remove the steering wheel.

CAUTION:

- Always use the steering wheel puller for removal to avoid deforming the steering wheel.
- If the steering wheel has been removed, make sure that the roll connector is not turned from the original position.

- (1) Disconnect the connector and remove the nut.
- (2) Put alignment marks and remove the steering wheel using a steering wheel puller.

Preparation tool:

Steering wheel puller

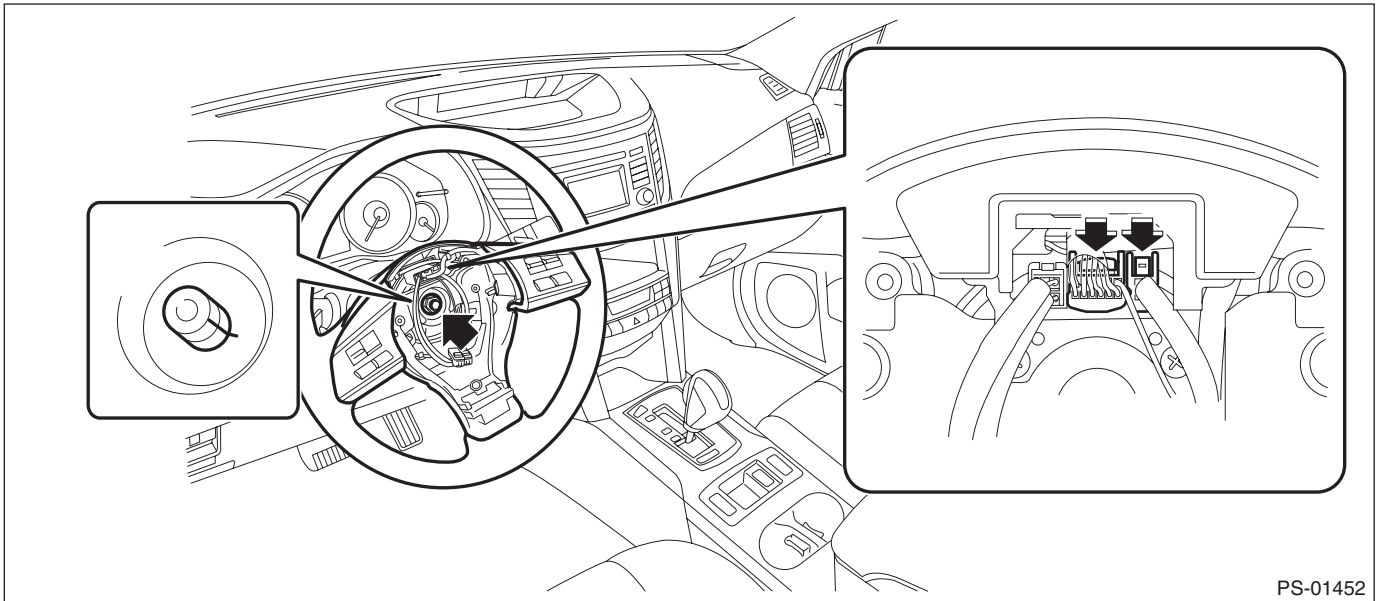

6) Remove the steering column cover.

- (1) Lower the lever of the steering column.
- (2) Release the claws and remove the screws, then detach the steering column lower cover.

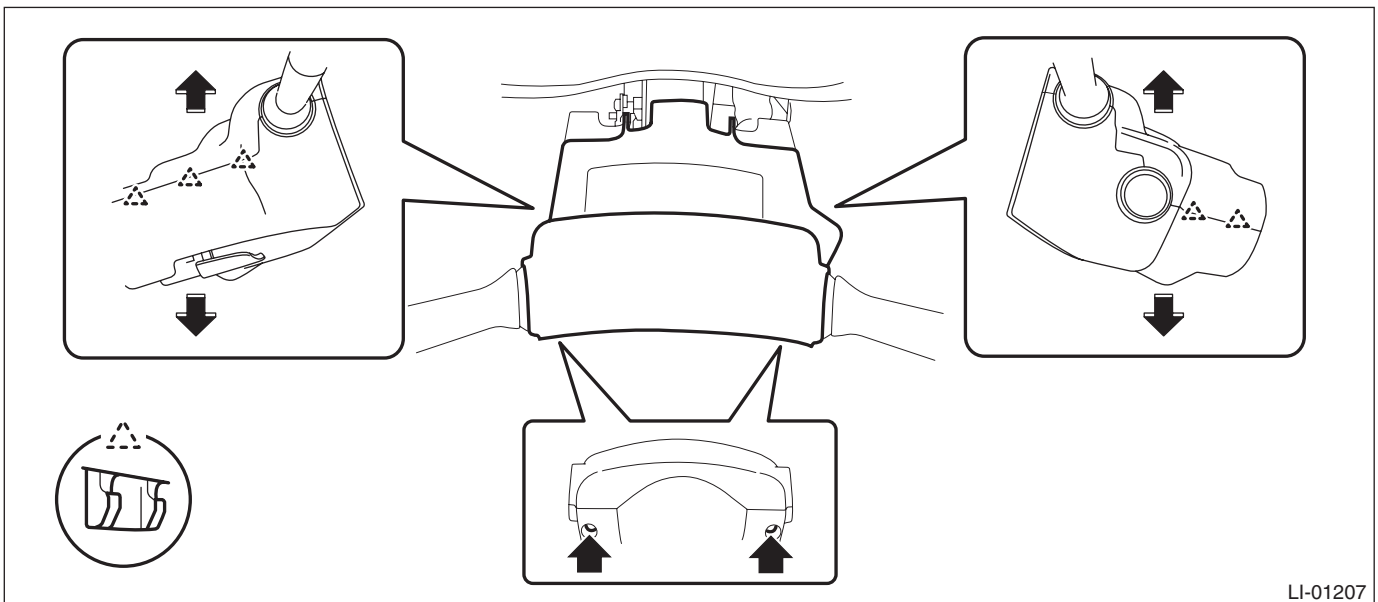

Combination Switch (Light)

(3) Separate the steering column upper cover and steering upper cover, and remove the steering column upper cover.

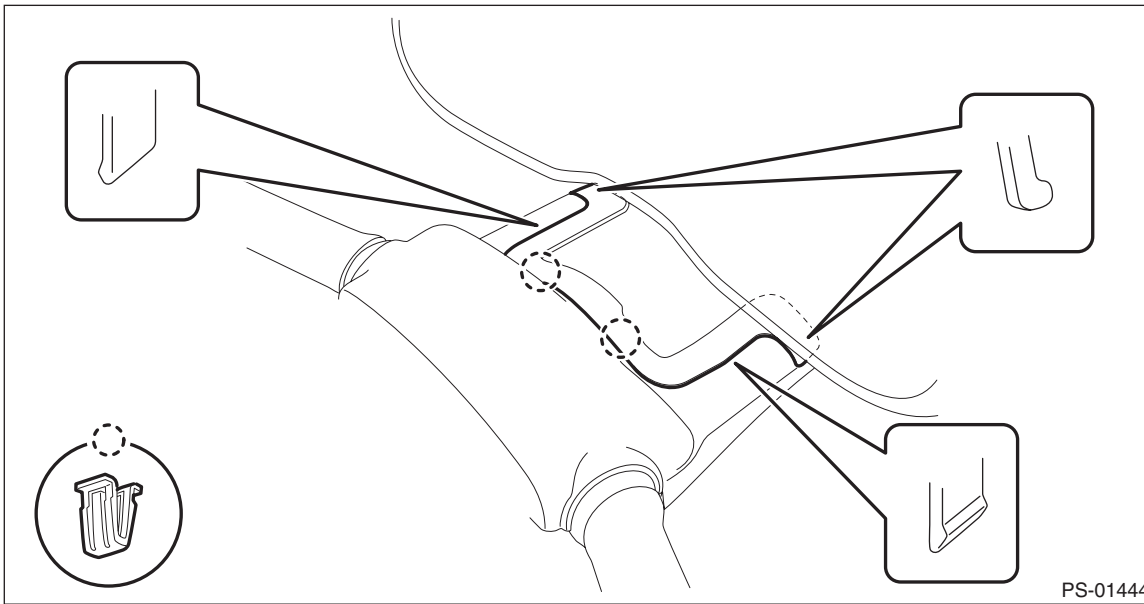

7) Remove the roll connector.

CAUTION:

Make sure that the roll connector is not turned from the original position.

- (1) Disconnect the connector under the roll connector.
- (2) Release the claws and remove the roll connector.

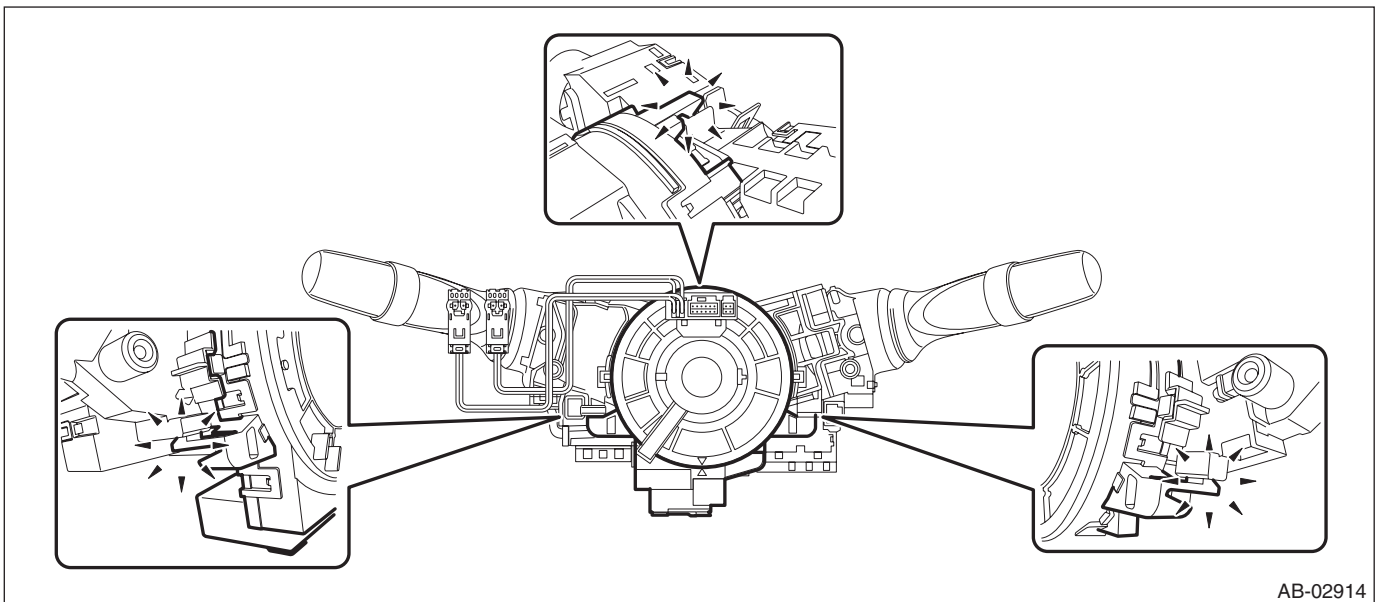

Combination Switch (Light)

LIGHTING SYSTEM

8) Remove the wiper switch assembly.

- (1) Disconnect the connector from wiper switch.
- (2) Release the claws, and pull out the wiper switch assembly.

CAUTION:

Do not press the claws with excessive force. They may be damaged.

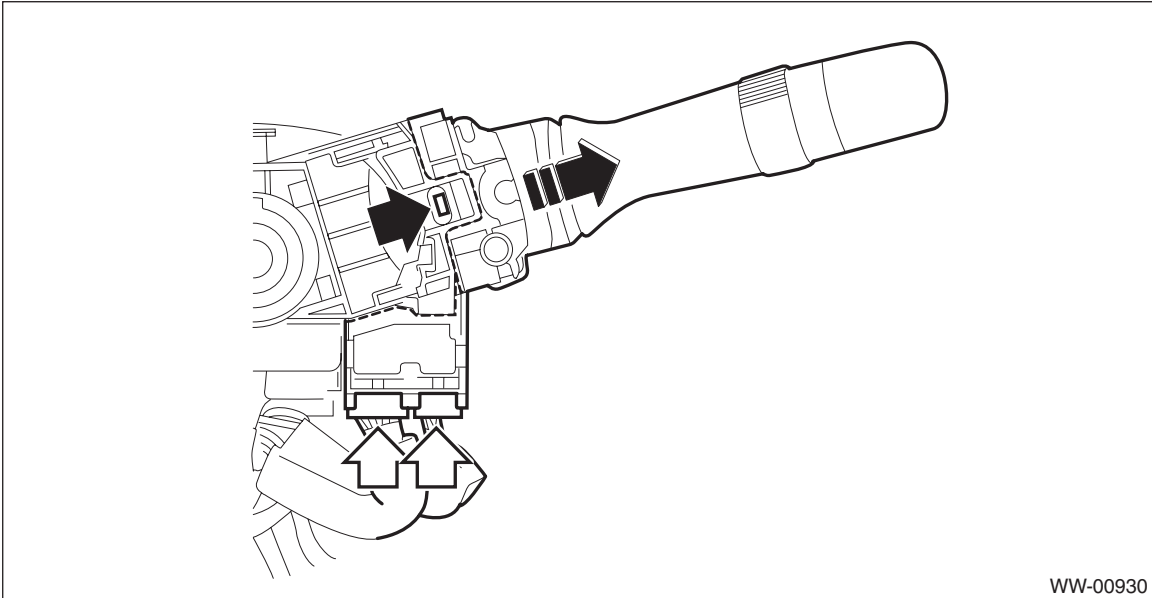

WW-00930

9) Remove the combination switch (light).

- (1) Disconnect the connector of combination switch.
- (2) Remove the screws and detach the combination switch (light).

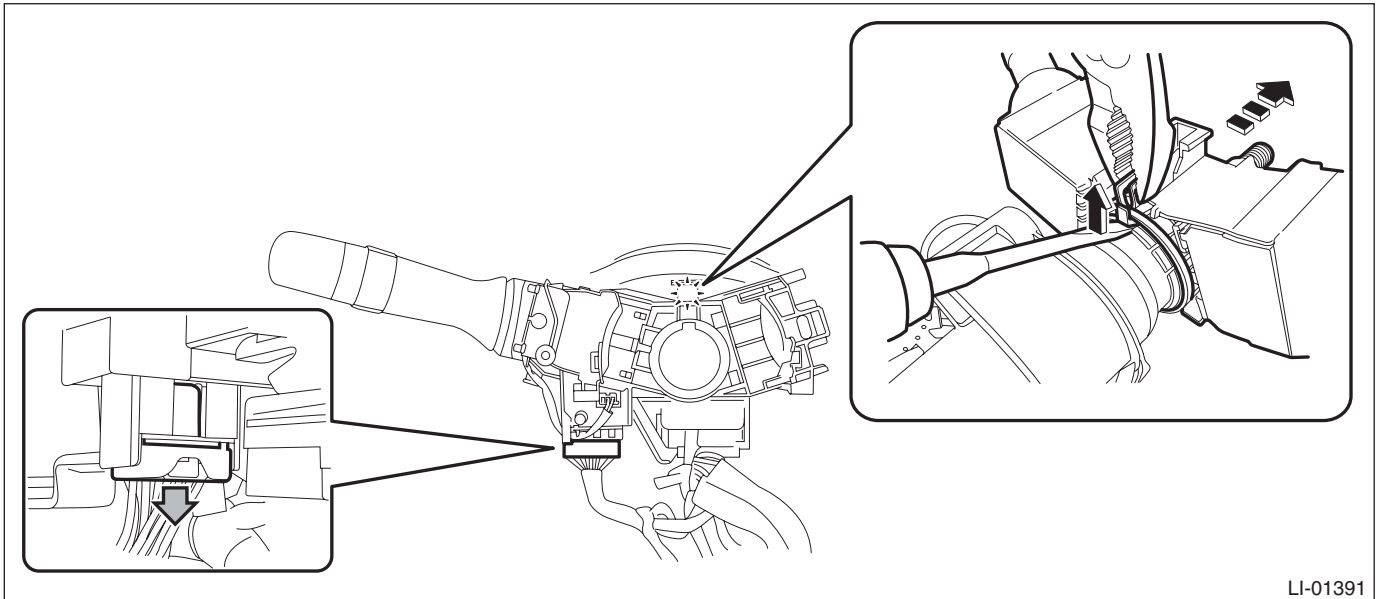

LI-01391

B: INSTALLATION

CAUTION:

- Before handling the airbag module, refer to “CAUTION” of “General Description” in “AIRBAG SYSTEM”. <Ref. to AB-10, CAUTION, General Description.>
 - Do not allow harness and connectors to interfere or get tangled up with other parts.
 - If the steering wheel and steering angle sensor (steering roll connector) are removed, adjust the steering angle sensor. <Ref. to VDC-20, ADJUSTMENT, VDC Control Module and Hydraulic Control Unit (VDCCM&H/U).>
- 1) Before installing steering wheel, be sure to adjust the direction of roll connector with steering. <Ref. to AB-109, ADJUSTMENT, Roll Connector.>
 - 2) Install each part in the reverse order of removal.

NOTE:

Align the alignment marks on the steering wheel and steering column.

Tightening torque:

Steering wheel: 39 N·m (3.98 kgf·m, 28.8 ft·lb)

Clearance:

Between column cover and steering wheel: 4 — 6 mm (0.16 — 0.24 in)

C: INSPECTION

- 1) Disconnect the combination switch (light) connector.
- 2) Measure the resistance between combination switch (light) connector terminals.

Preparation tool:

Circuit tester

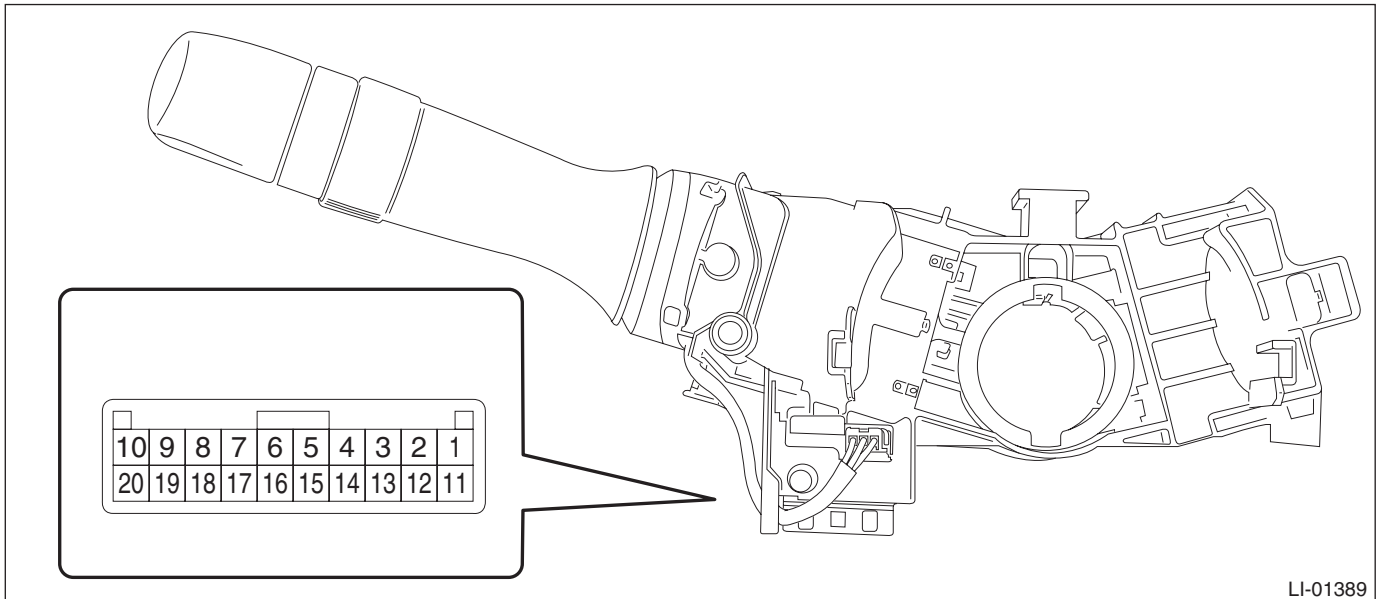

LI-01389

- 3) Replace the combination switch (light) if the inspection result is not within the standard value.

Combination Switch (Light)

LIGHTING SYSTEM

1. LIGHTING SWITCH

Terminal No.	Inspection Conditions	Standard
18, 19, 20 — 12	Switch OFF	1 M Ω or more
19 — 12	Switch AUTO	Less than 1 Ω
18 — 12	Switch 1 (TAIL)	Less than 1 Ω
20, 18 — 12	Switch 2 (HEAD)	Less than 1 Ω

2. DIMMER & PASSING SWITCH

Terminal No.	Inspection Conditions	Standard
11, 17 — 12	Switch PASS	Less than 1 Ω
11 — 12	Switch UP	Less than 1 Ω

3. TURN SIGNAL SWITCH

Terminal No.	Inspection Conditions	Standard
13 — 12	Switch TURN (RH)	Less than 1 Ω
15 — 12	Switch TURN (LH)	Less than 1 Ω

4. FRONT FOG LIGHT SWITCH

Terminal No.	Inspection Conditions	Standard
4 — 3	Switch OFF	1 M Ω or more
	Switch ON	Less than 1 Ω