

# Relay and Fuse

## LIGHTING SYSTEM

### 2. Relay and Fuse

#### A: LOCATION

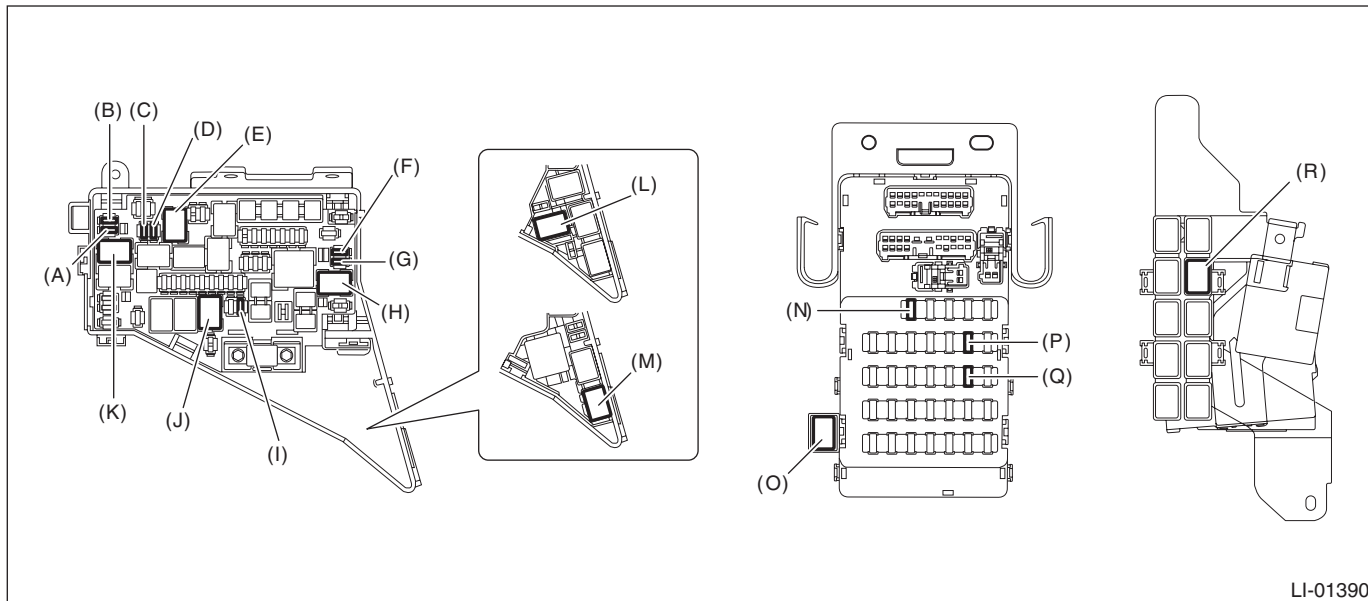

LI-01390

Main fuse box	Fuse 15A (front combination light RH)	(A)
	Fuse 15A (front combination light LH)	(B)
	Fuse 10A (front combination light LH)	(C)
	Fuse 10A (front combination light RH)	(D)
	Headlight relay (Hi)	(E)
	Fuse 10A (front fog light LH)	(F)
	Fuse 10A (front fog light RH)	(G)
	Front fog light relay	(H)
	Fuse 10A (rear combination light)	(I)
	Tail & Illumination relay	(J)
	Headlight relay (Lo)	(K)
A/C relay holder (in main fuse box)	Daytime running light relay (H4 model)	(L)
	Daytime running light relay (H6 model)	(M)
Relay & fuse box	Fuse 15A (trailer connector)	(N)
	Back-up light relay (model without keyless access) (5AT model)	(O)
	Fuse 7.5A (turn signal & hazard unit)	(P)
	Fuse 7.5A (inhibitor switch, back-up light relay)	(Q)
Smart module bracket	Back-up light relay (model with keyless access) (5AT model)	(R)

#### NOTE:

For other related fuses, refer to the wiring diagram. <Ref. to WI-15, Power Supply Circuit.>

## B: INSPECTION

### 1. CHECK FUSE

- 1) Remove the fuse and inspect visually.
- 2) If the fuse is blown out, replace the fuse.

NOTE:

If the fuse is blown again, check the system wiring harness.

### 2. CHECK RELAY

- 1) Check the resistance between relay terminals.

Terminal No.	Inspection conditions	Specification	Circuit
1 — 2	Always	1 MΩ or more	<p style="text-align: right; margin-top: 10px;">SR-00180</p>
1 — 2	Apply battery voltage between 4 — 3 terminals.	Less than 1 Ω	

Terminal No.	Inspection conditions	Specification	Circuit
1 — 2	Always	1 MΩ or more	<p style="text-align: right; margin-top: 10px;">SL-01085</p>
1 — 4	Always	Less than 1 Ω	
1 — 2	Apply battery voltage between 3 — 5 terminals.	Less than 1 Ω	

- 2) Replace the relay if the inspection result is not within the standard value.