

13. Rear Door Latch and Door Lock Actuator Assembly

A: REMOVAL

- 1) Disconnect the ground cable from battery.
- 2) Remove the rear door trim. <Ref. to EI-60, REAR DOOR, REMOVAL, Door Trim.>
- 3) Remove the sealing cover.

CAUTION:

- Carefully remove the butyl tape. Excessive force will easily break the cover.
- If the sealing cover gets broken, replace it with a new part.

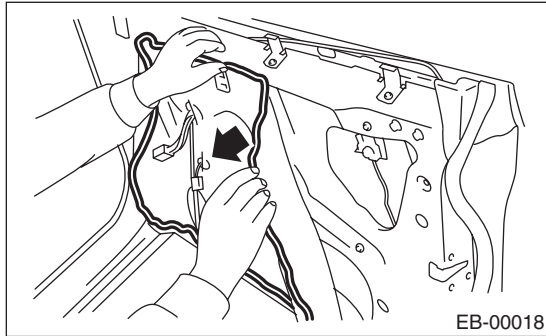

- 4) Remove the rear door glass. <Ref. to GW-30, REMOVAL, Rear Door Glass.>
- 5) Remove the rear door latch and door lock actuator assembly.
 - (1) Disconnect the connector.
 - (2) Remove the screws, and remove the rear door latch & door lock actuator assembly.

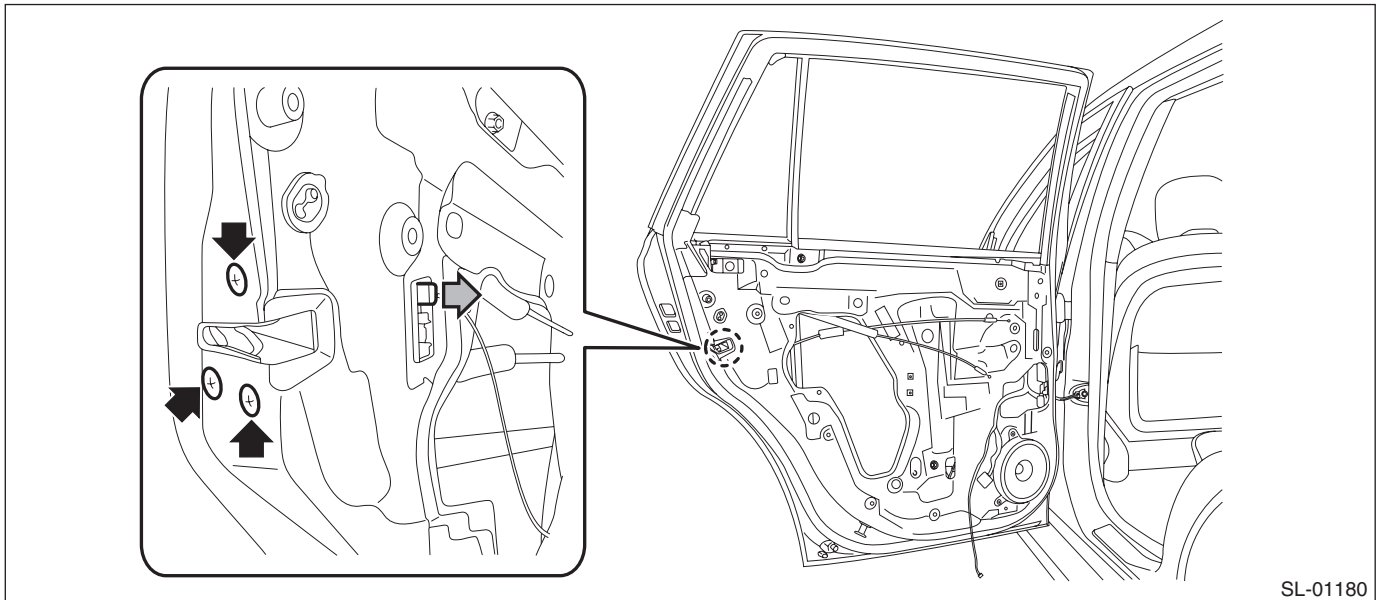

B: INSTALLATION

- 1) Before installation, check the following items.
 - Cable is free from deformation.
 - Grease is applied sufficiently to lever joints.
 If grease is insufficient, add it as necessary before assembling.
- 2) Install each part in the reverse order of removal.

Tightening torque:

Refer to “COMPONENT” of “General Description”. <Ref. to SL-2, DOOR LOCK ASSEMBLY, COMPONENT, General Description.>

NOTE:

Make sure the child safety lock works correctly after installation.

Rear Door Latch and Door Lock Actuator Assembly

SECURITY AND LOCKS

C: INSPECTION

1. REAR DOOR LATCH

Check if the rear door latch operates normally.

If the cable is faulty, replace the rear door latch & door lock actuator assembly.

2. REAR DOOR LOCK ACTUATOR

1) Disconnect the rear door lock actuator connector.

2) Check the door lock operation by applying battery voltage between the terminals of rear door lock actuator.

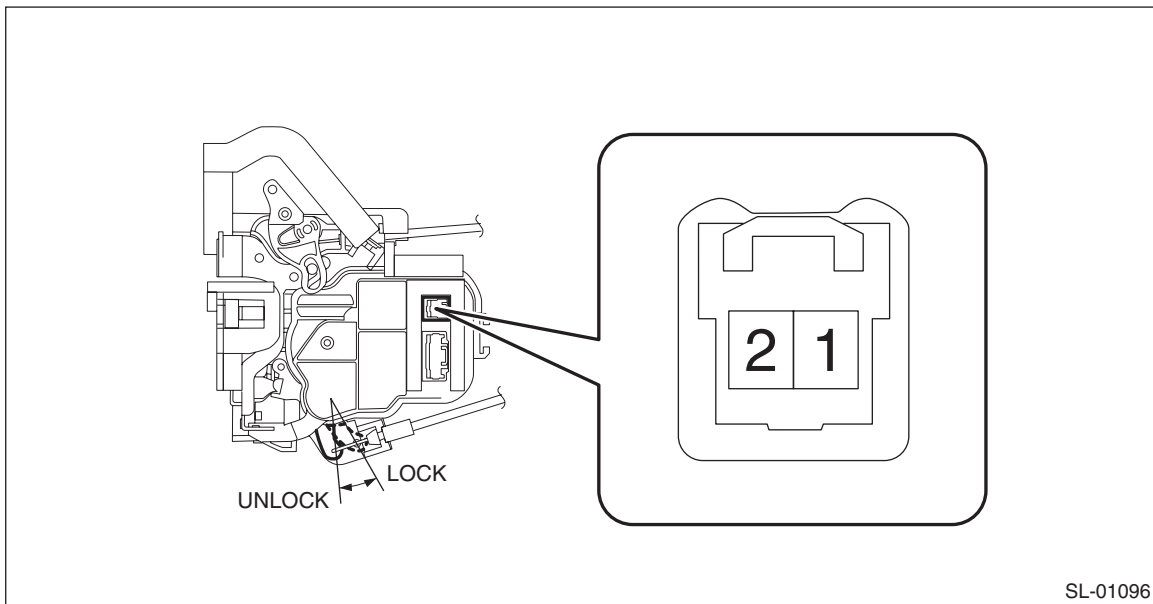

Inspection conditions	Terminal No.	
	1	2
LOCK → UNLOCK	-	+
UNLOCK → LOCK	+	-

3) If the actuator does not operate normally, replace the rear door latch & door lock actuator assembly.