

30. Immobilizer Antenna

A: REMOVAL

1. MODEL WITHOUT KEYLESS ACCESS

- 1) Disconnect the ground cable from battery.
- 2) Remove the steering column cover.
 - (1) Remove the screws by turning the steering wheel to right and left.

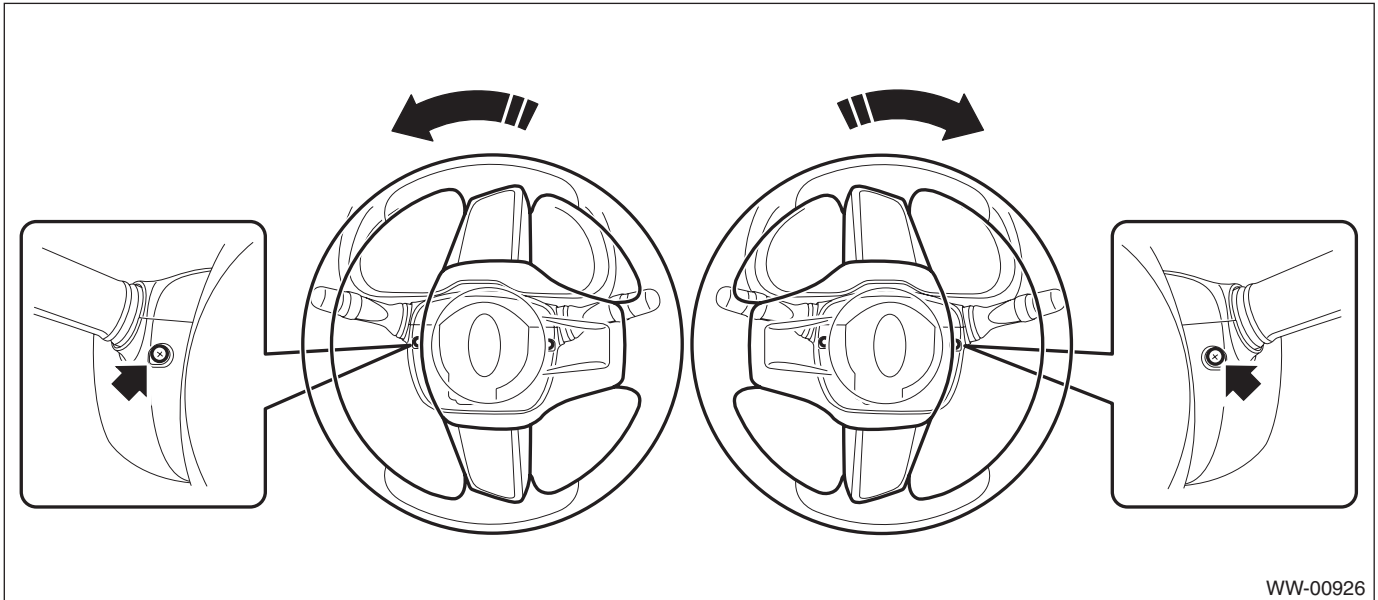

- (2) Release the claws and remove the steering column lower cover.

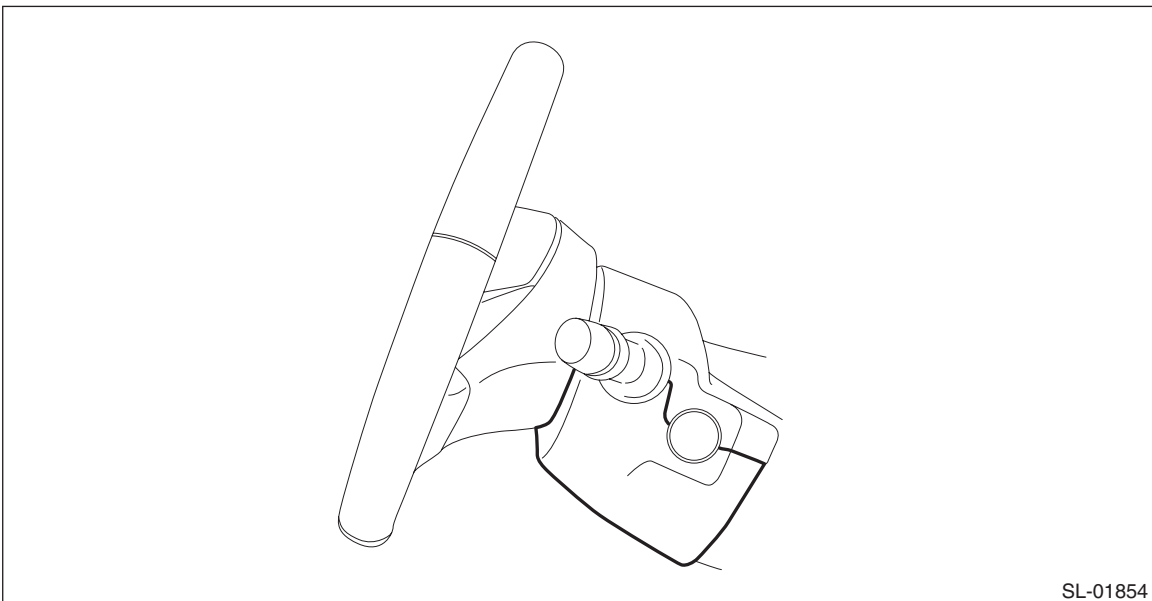

(3) Separate the steering column upper cover and steering upper cover, and remove the steering column upper cover.

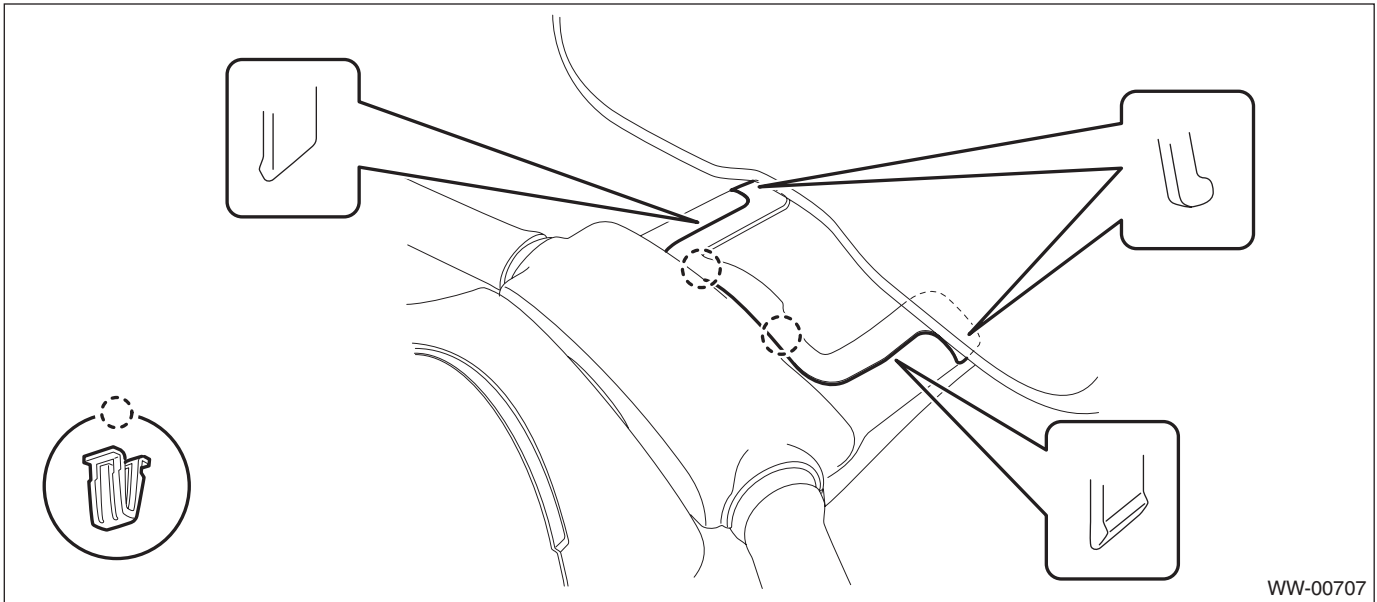

3) Remove the immobilizer antenna.

CAUTION:

Do not apply excessive force to remove the immobilizer antenna and lock. Otherwise they may be broken because those parts are the products made of a plastic.

- (1) Disconnect the connector and remove the screw.
- (2) Remove the ignition illumination light and release the claws, then detach the immobilizer antenna.

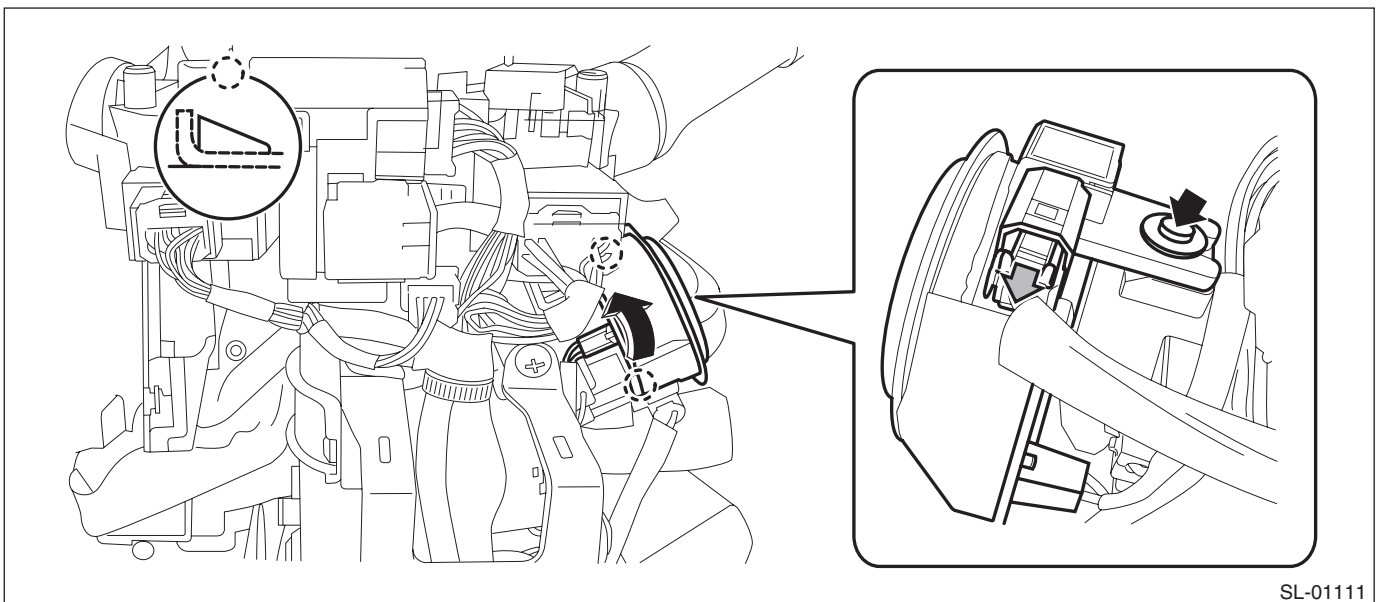

2. MODEL WITH KEYLESS ACCESS

- 1) Remove the instrument panel lower cover. <Ref. to EI-63, REMOVAL, Instrument Panel Lower Cover.>
- 2) Remove the center panel assembly.

CAUTION:

Do not put your finger on the fin of the air vent grille. Doing so may damage the fin.

Immobilizer Antenna

SECURITY AND LOCKS

(1) Attach the protective tape (a) to the meter visor.

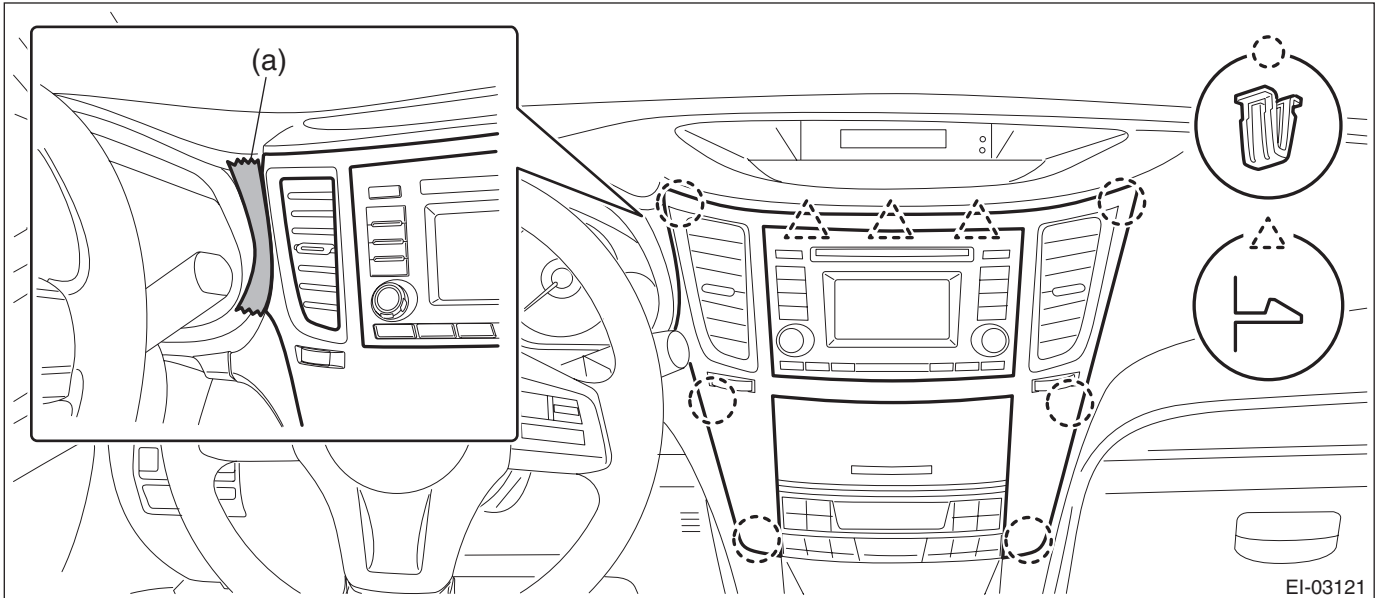

(2) Insert a finger into the air vent grille and release the left and right clips at the top of the center panel. (A), (B)

(3) Insert a finger into the air vent grille and release the left and right clips at the center of the center panel. (C), (D)

(4) Release the clips at the bottom of the center panel and remove the center panel assembly.

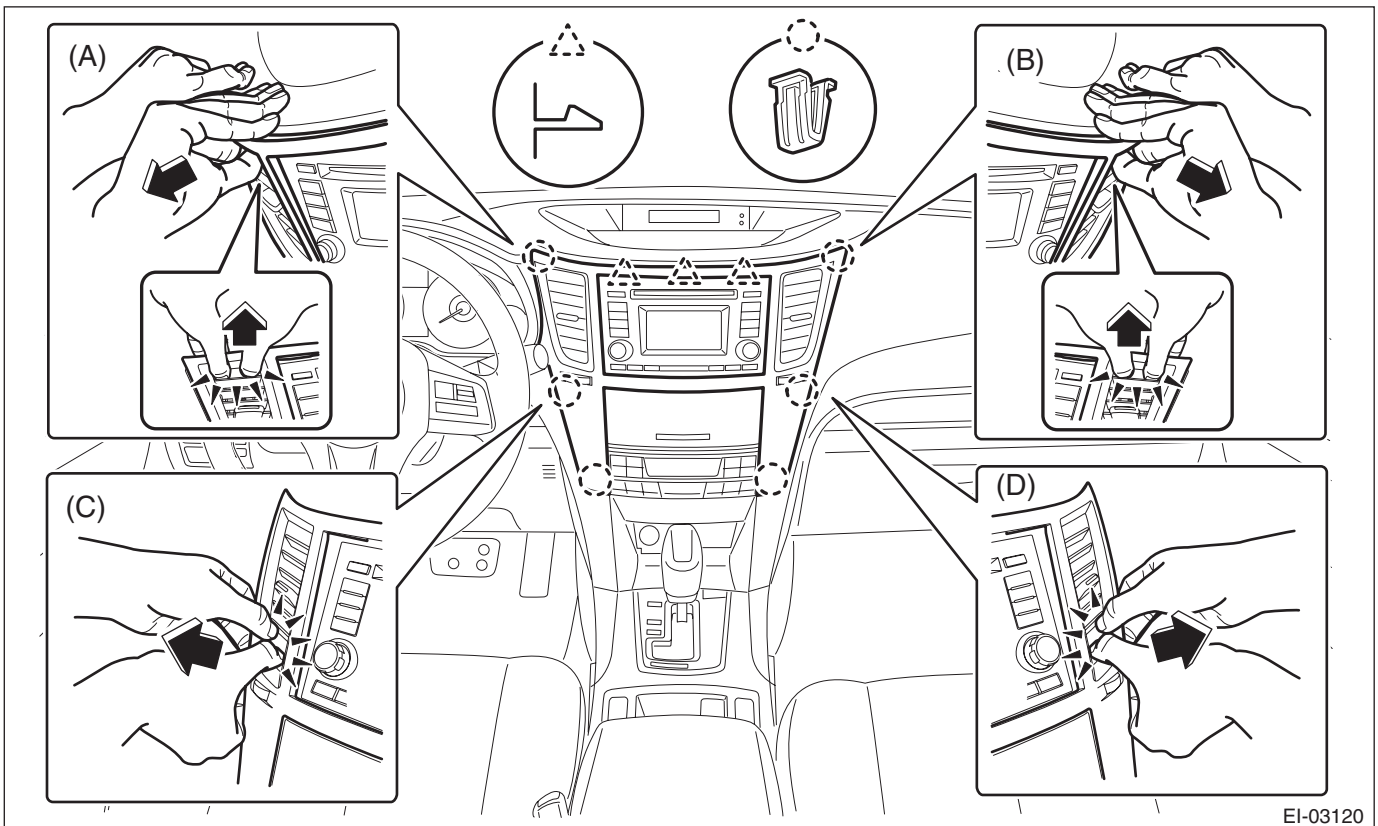

- 3) Remove the screws and release the claws, then detach the starter cover assembly.

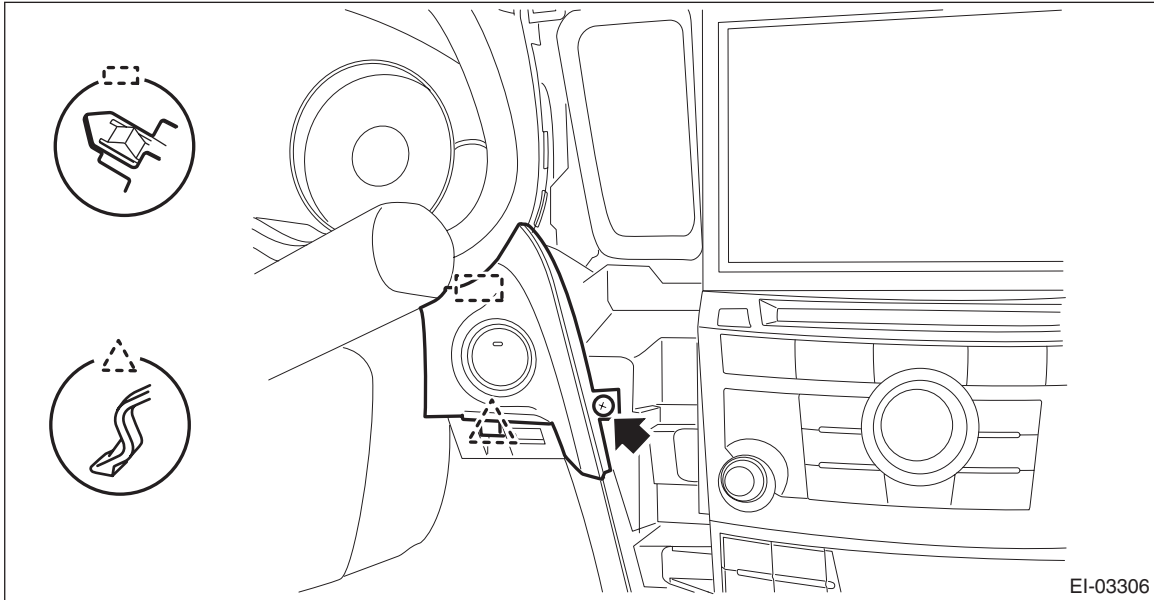

- 4) Release the claws and remove the push button ignition switch from the starter cover assembly.

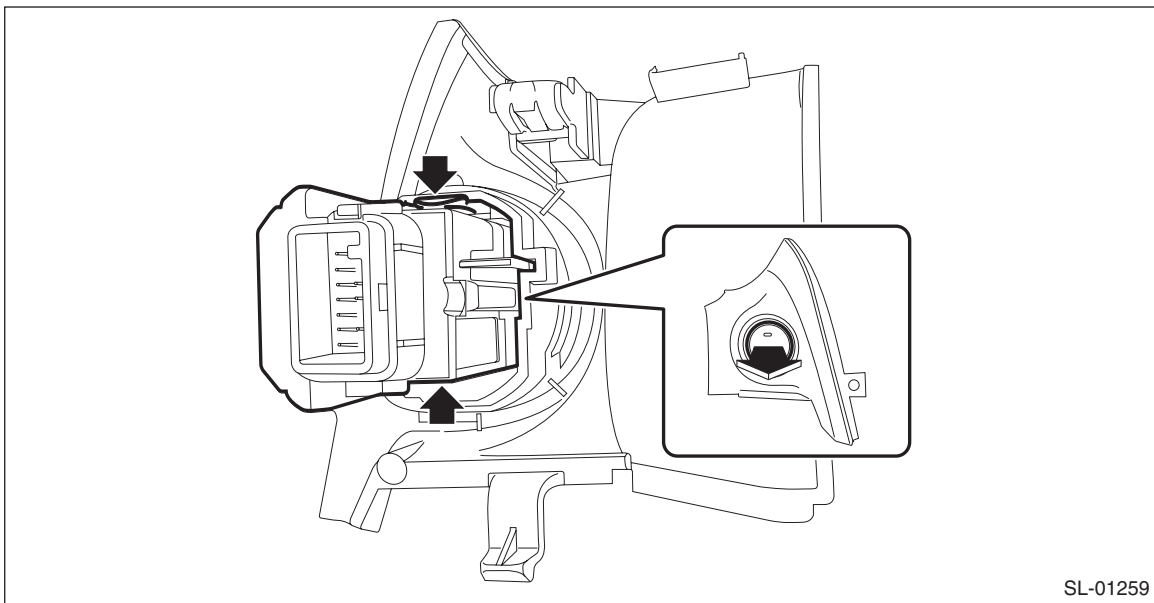

B: INSTALLATION

Install each part in the reverse order of removal.