

# General Description

## WIPER AND WASHER SYSTEMS

---

### 1. General Description

#### A: SPECIFICATION

Front wiper motor	Input	12 V — 72 W or less
Rear wiper motor	Input	12 V — 42 W or less
Front washer motor	Pump type	Centrifugal
	Input	12 V — 36 W or less
Rear washer motor	Pump type	Centrifugal
	Input	12 V — 36 W or less

### B: COMPONENT

#### 1. FRONT WIPER

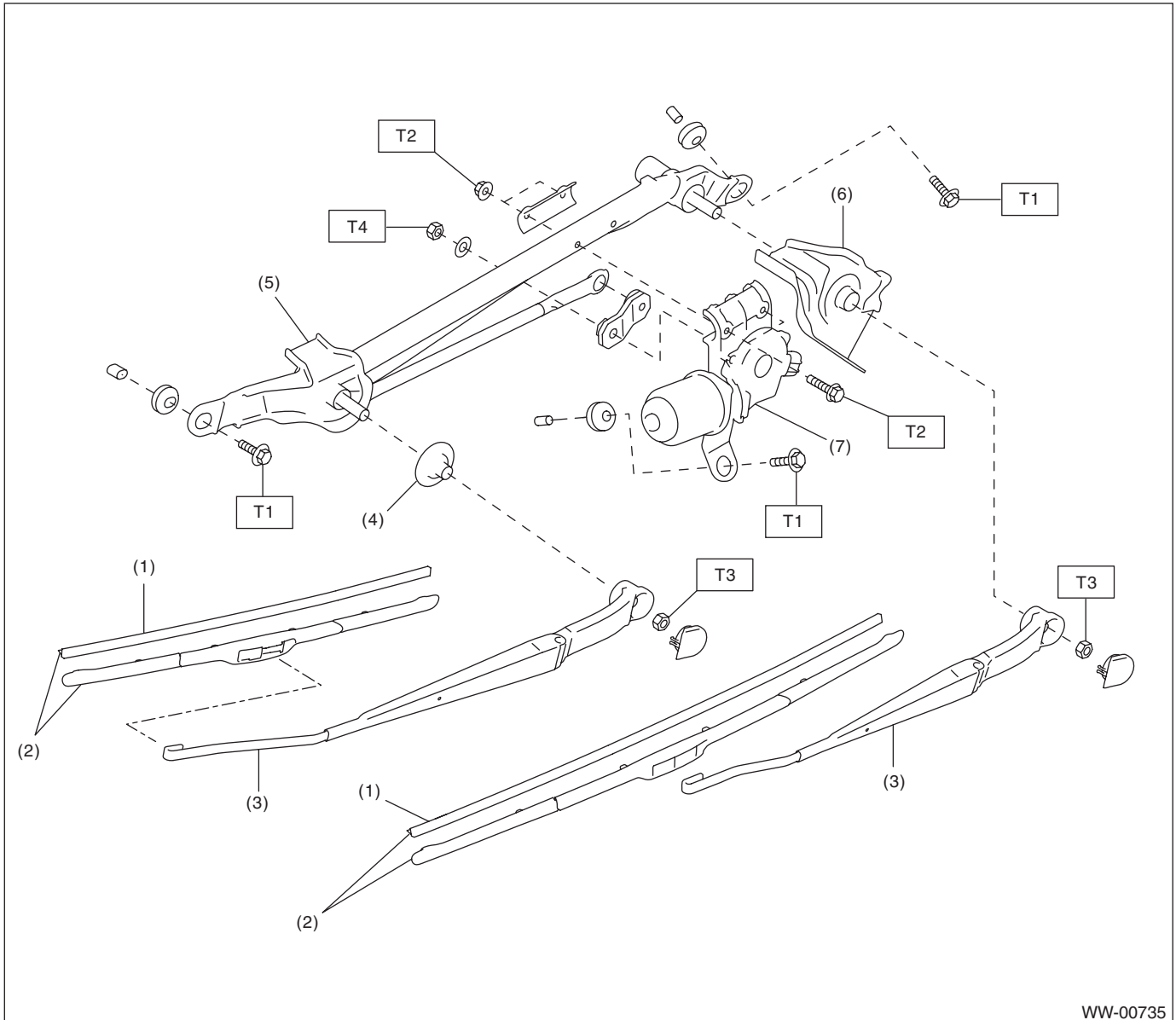

WW-00735

- |                      |                          |
|----------------------|--------------------------|
| (1) Wiper rubber     | (5) Wiper link ASSY      |
| (2) Wiper blade ASSY | (6) Pivot cover C        |
| (3) Wiper arm ASSY   | (7) Wiper motor assembly |
| (4) Pivot cover B    |                          |

**Tightening torque: N-m (kgf-m, ft-lb)**

**T1: 6 (0.61, 4.4)**

**T2: 7.5 (0.76, 5.5)**

**T3: 22 (2.24, 16.2)**

**T4: 32.1 (3.27, 23.7)**

# General Description

## WIPER AND WASHER SYSTEMS

### 2. REAR WIPER

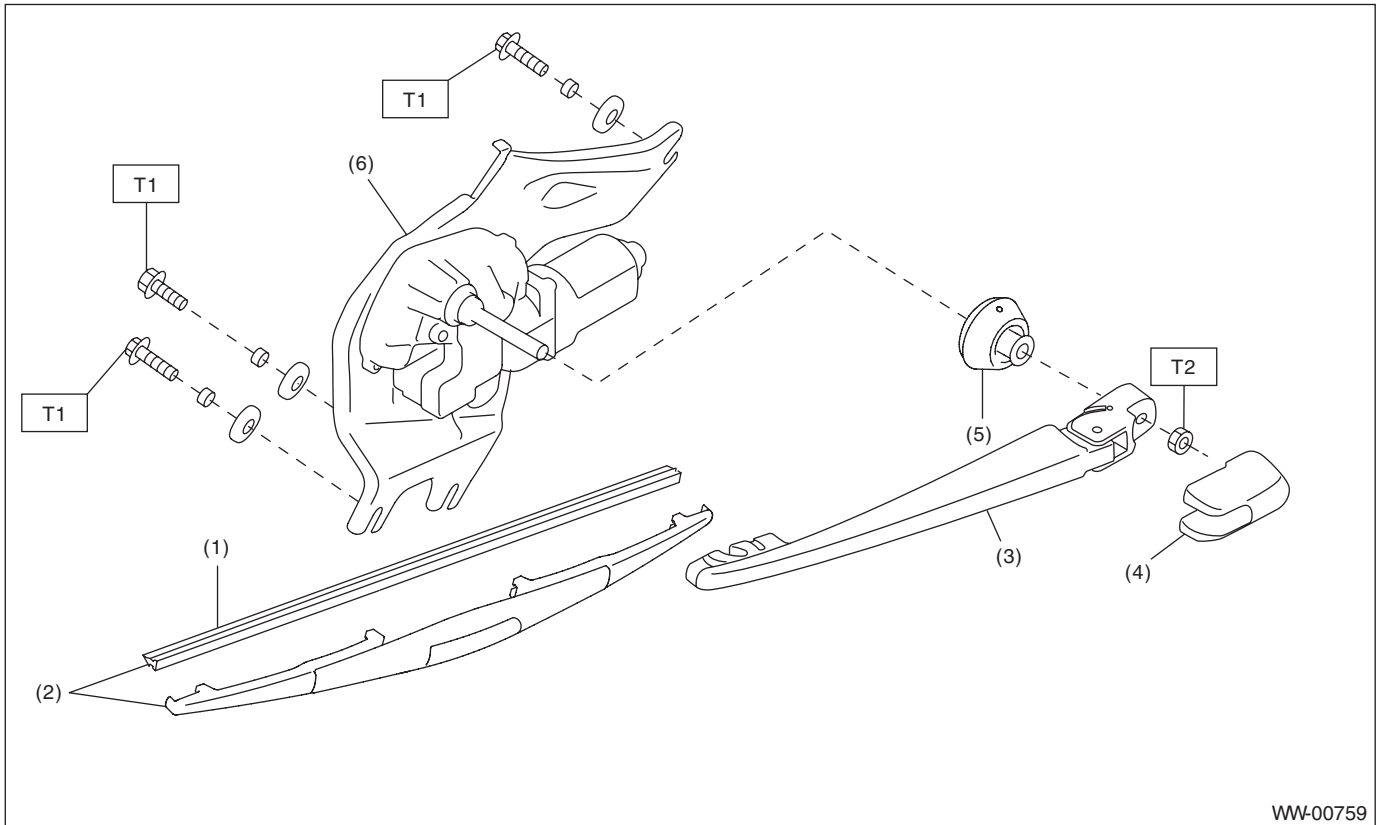

- |                      |                      |
|----------------------|----------------------|
| (1) Wiper rubber     | (4) Wiper arm cover  |
| (2) Wiper blade ASSY | (5) Pivot cap        |
| (3) Wiper arm        | (6) Wiper motor ASSY |

**Tightening torque: N·m (kgf·m, ft·lb)**

**T1: 7 (0.71, 5.2)**

**T2: 8 (0.82, 5.9)**

### 3. WASHER TANK

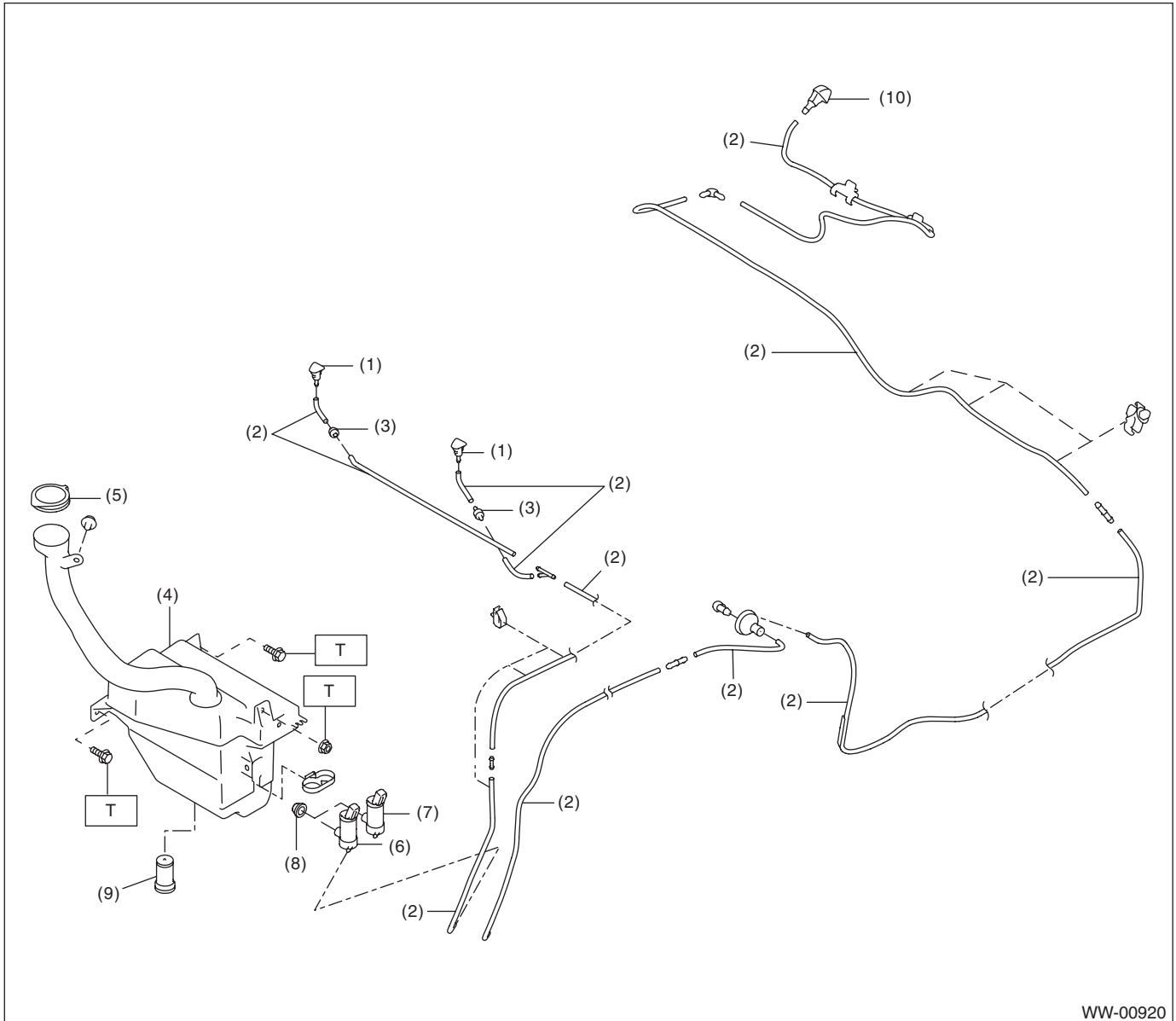

WW-00920

- |                         |  |
|-------------------------|--|
| (1) Front washer nozzle | (6) Front washer motor                       |
| (2) Washer hose         | (7) Rear washer motor (OUTBACK model only)   |
| (3) Check valve         | (8) Grommet                                  |
| (4) Washer tank         | (9) Washer fluid level sensor                |
| (5) Washer tank cap     | (10) Rear washer nozzle (OUTBACK model only) |

**Tightening torque: N·m (kgf·m, ft·lb)**

**T: 6 (0.61, 4.4)**

# General Description

## WIPER AND WASHER SYSTEMS

### C: CAUTION

- Connect the connectors and hoses securely during reassembly.
- After reassembly, make sure functional parts operates smoothly.
- Be careful with the airbag system wiring harness which passes near electrical parts and switches.
- Yellow connectors and harnesses with yellow tapes around them are the connectors and harnesses for the airbag system. Using a tester above such circuits may cause malfunction of airbag system. Follow the cautions for the airbag system in this case. <Ref. to AB-10, CAUTION, General Description.>
- When connecting the pipe hoses, be careful not to cause bend or blockage.
- If even a small amount of silicon oil or grease enters tank and washer fluid passages, an oil film will be formed on the glass and will cause the wiper to chatter and judder. Make sure that no oil comes into contact with the system.

### D: PREPARATION TOOL

#### 1. SPECIAL TOOL

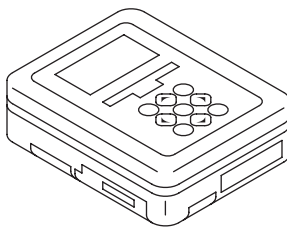
ILLUSTRATION	TOOL NUMBER	DESCRIPTION	REMARKS
 <p>ST1B022XU0</p>	1B022XU0	SUBARU SELECT MONITOR III KIT	Used for setting of each function and trouble-shooting for electrical system.

#### 2. GENERAL TOOL

TOOL NAME	REMARKS
Circuit tester	Used for checking voltage and continuity.

#### NOTE:

Refer to the data described below, prepare the materials to make a front washer nozzle adjustment tool.

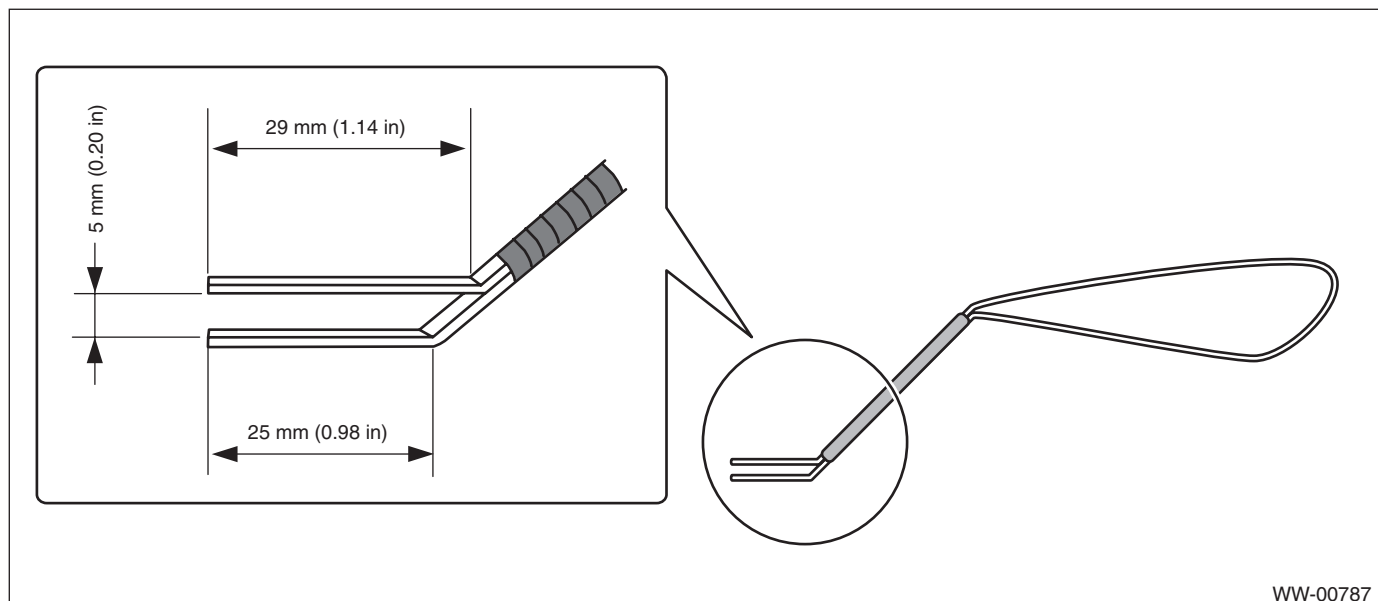

## Materials

- Vertebra of wiper blade which is to be discarded
- Vinyl tape

## Steps of making a front washer nozzle adjustment tool

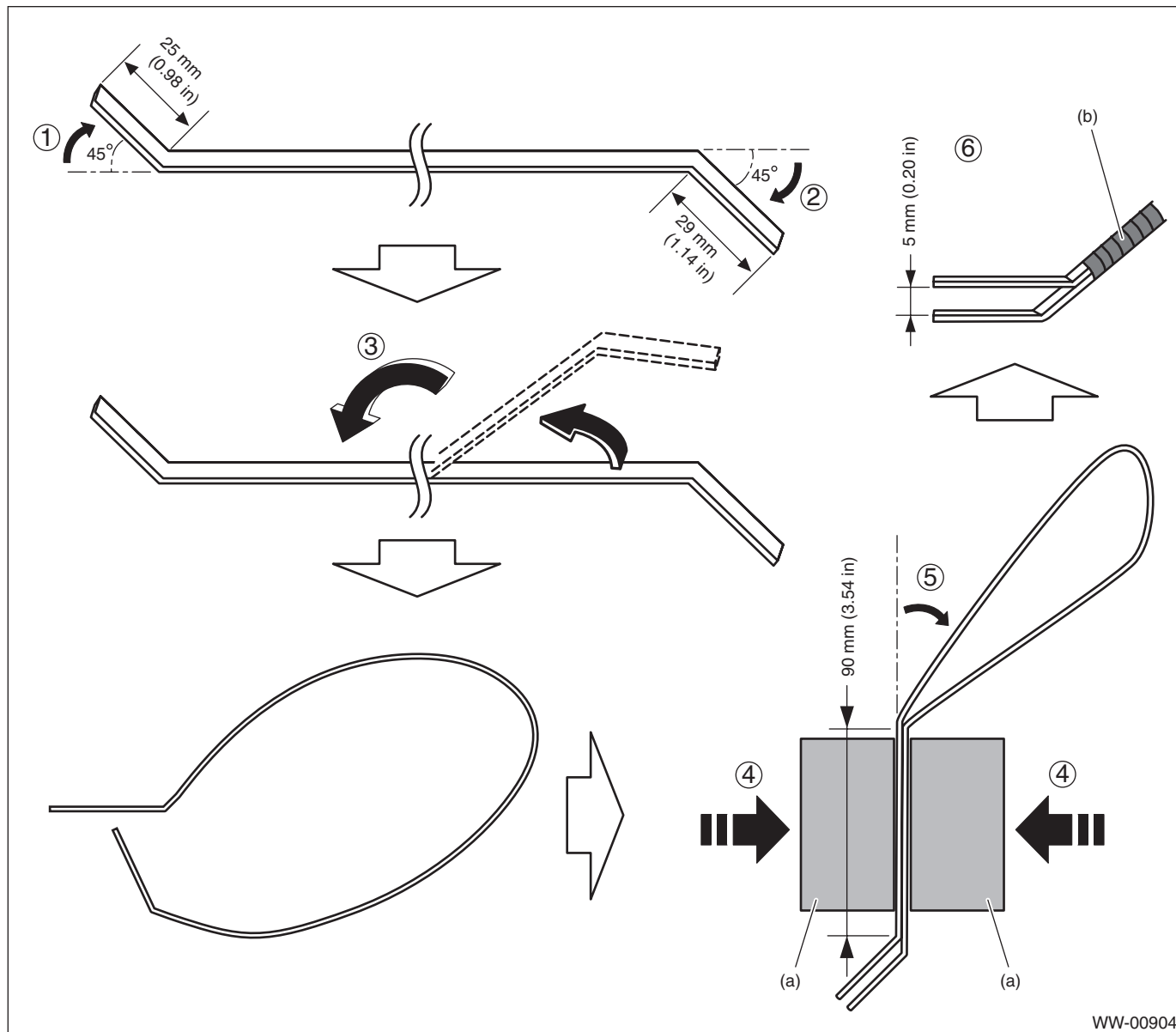

WW-00904

1. Bend the vertebra at the position 25 mm (0.98 in) away from its end by 45°.
2. Bend the vertebra at the position 29 mm (1.14 in) away from the other end by 45°.
3. Double up the vertebra so that the longer end (29 mm (1.14 in)) comes upward.
4. Secure the vertebra with a vise (a) so that the tip clearance becomes 5 mm (0.20 in).
5. Bend the vertebra at the position approximately 90 mm (3.54 in) away from the bending point for the longer end.
6. Check that the tip clearance is 5 mm (0.20 in), and secure the vertebra with vinyl tape (b).