

3. Combination Switch (Wiper)

A: REMOVAL

- 1) Disconnect the ground cable from battery.
- 2) Remove the steering column cover.
 - (1) Remove the screws by turning the steering wheel to right and left.

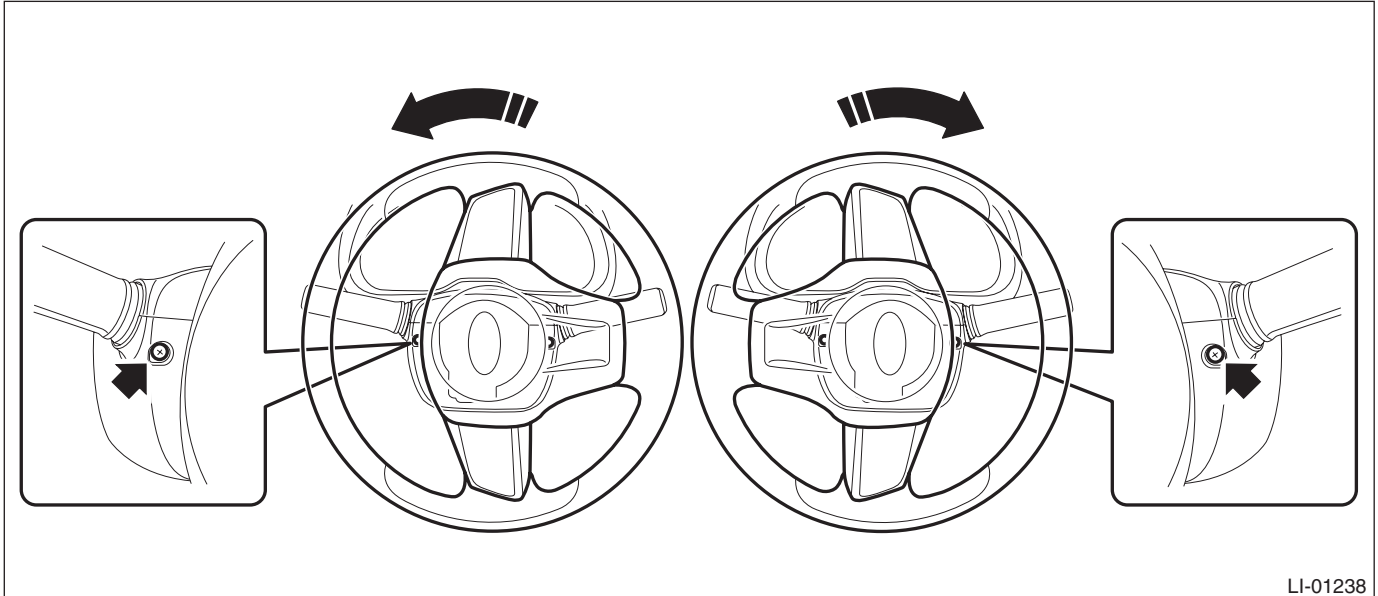

- (2) Release the claws and remove the steering column lower cover.

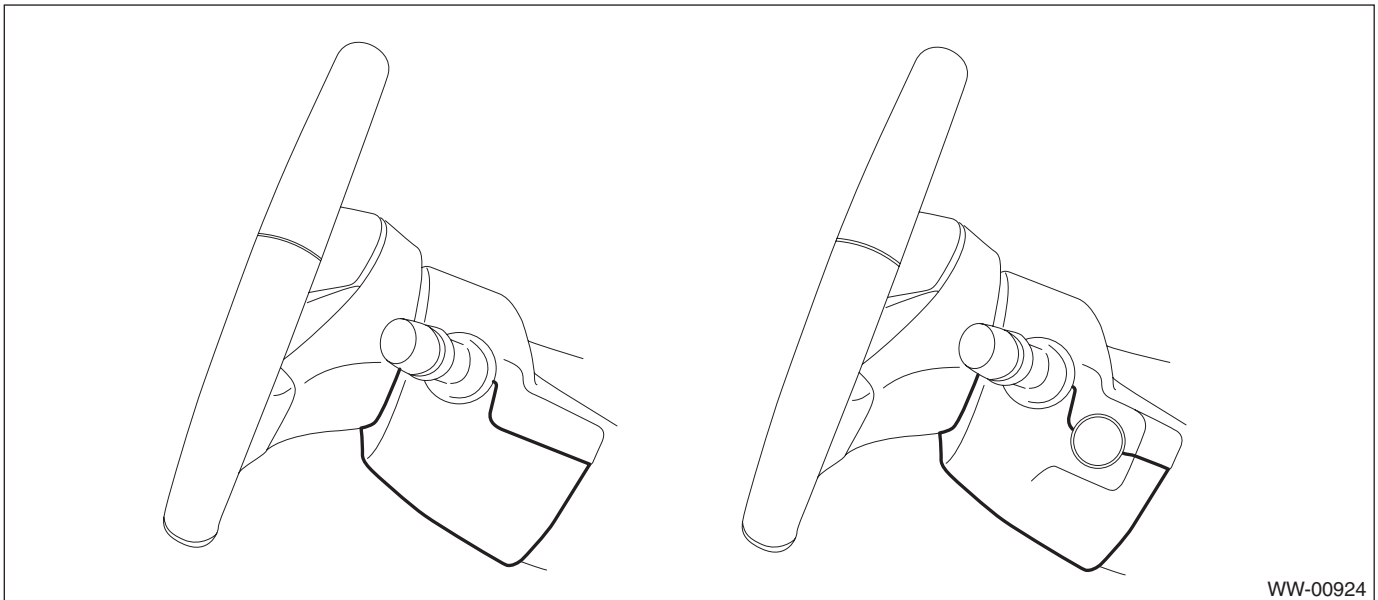

Combination Switch (Wiper)

WIPER AND WASHER SYSTEMS

(3) Separate the steering column upper cover and steering upper cover, and remove the steering column upper cover.

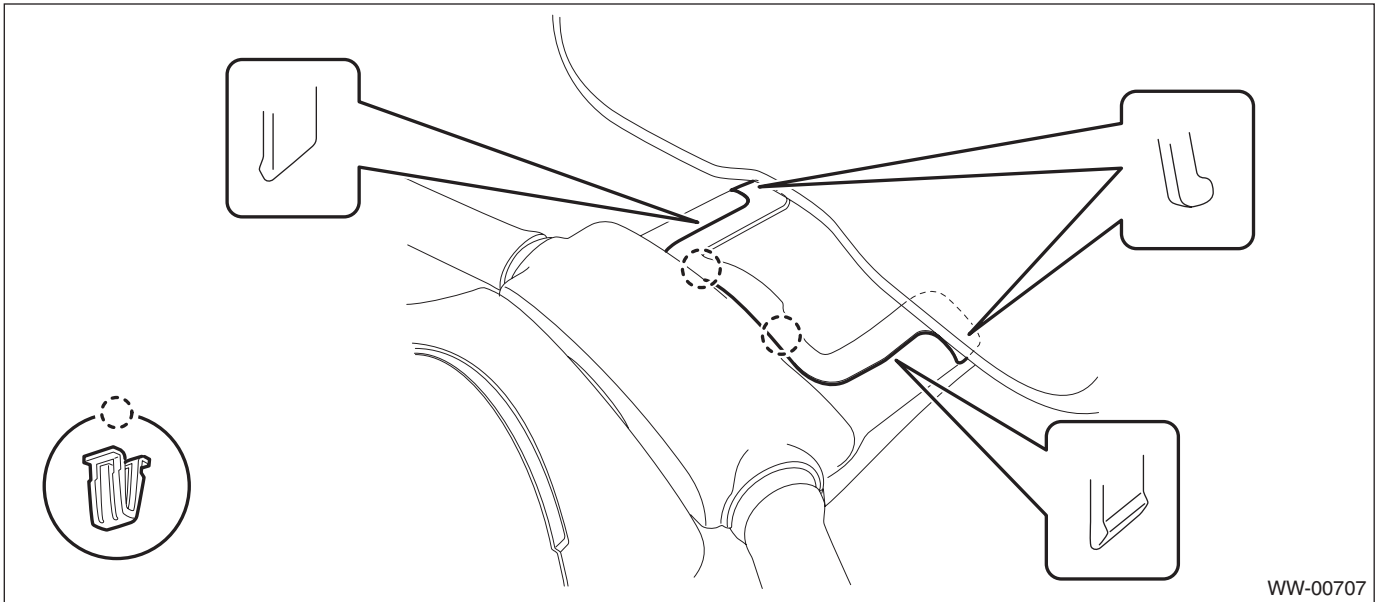

WW-00707

3) Remove the wiper switch assembly.

(1) Disconnect the connector from wiper switch.

(2) Release the claws, and pull out the wiper switch assembly.

CAUTION:

Do not press the claws with excessive force. They may be damaged.

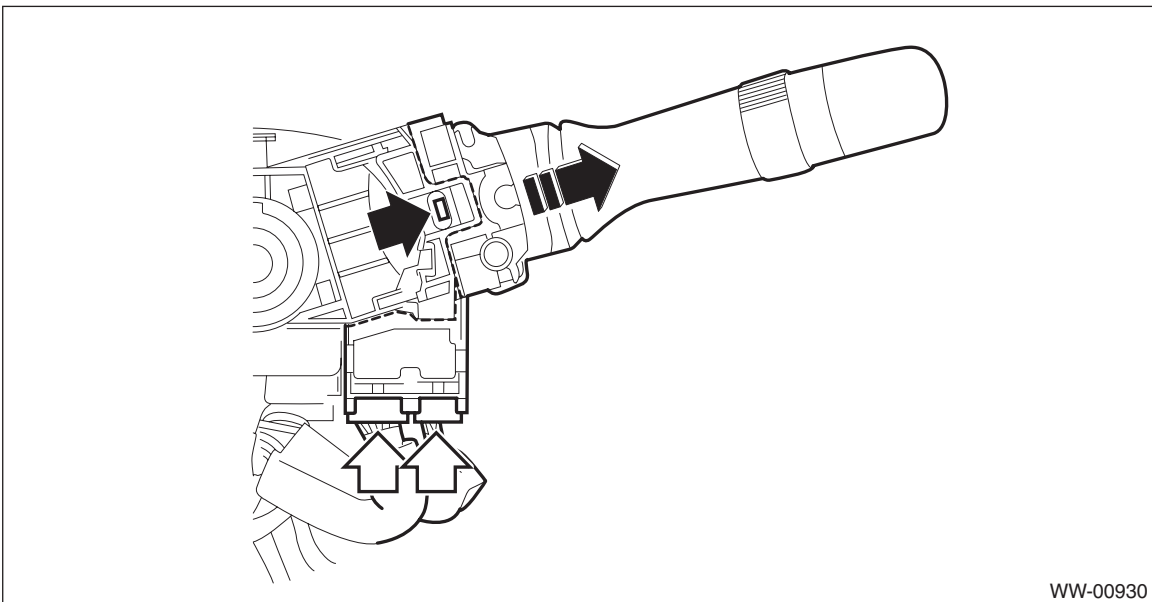

WW-00930

B: INSTALLATION

Install each part in the reverse order of removal.

C: INSPECTION

1. INSPECTION OF SWITCH UNIT

1) Operate the switches to check the continuity between terminals.

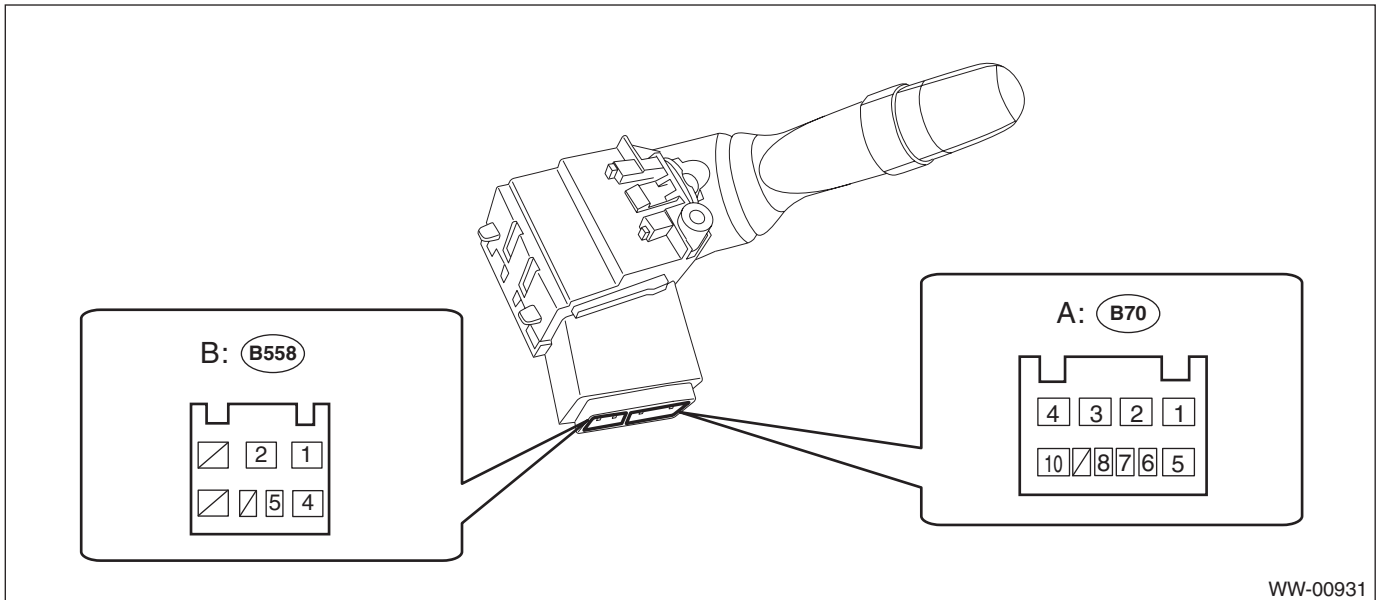

	Switch position	Terminal No.	Standard
Front	Washer ON	B1 and B2	Less than 1 Ω
	OFF	A2 and A4	Less than 1 Ω
	INT	A2 and A4	Less than 1 Ω
	LO	A2 and A3	Less than 1 Ω
	HI	A3 and A1	Less than 1 Ω
Rear	Washer ON (wiper interlock operation)	A10 and B2 B4 and B2	Less than 1 Ω
	ON	B4 and B2	Less than 1 Ω
	INT	B5 and B2	Less than 1 Ω
	OFF	A10 and B2 B5 and B2 B4 and B2	1 MΩ or more
	Washer ON	A10 and B2	Less than 1 Ω

2) Replace the switch if the inspection result is not within the standard value.

2. FRONT WIPER

1) Check with Subaru Select Monitor

(1) Check the input signal when the front wiper switch is turned to LO or HI, using the current data display of body integrated unit.

(2) Does the input signal change corresponding to the switch operation?

- **Yes** → Finish the diagnosis.
- **No** →
 1. Check the harness.
 2. Check the input voltage of body integrated unit.

Connector & terminal

(B280) No. 2 (+) — Chassis ground (-):

3. Replace the body integrated unit. <Ref. to SL-80, Body Integrated Unit.>

Combination Switch (Wiper)

WIPER AND WASHER SYSTEMS

2) Check the intermittent operation (inspection of the wiper switch alone).

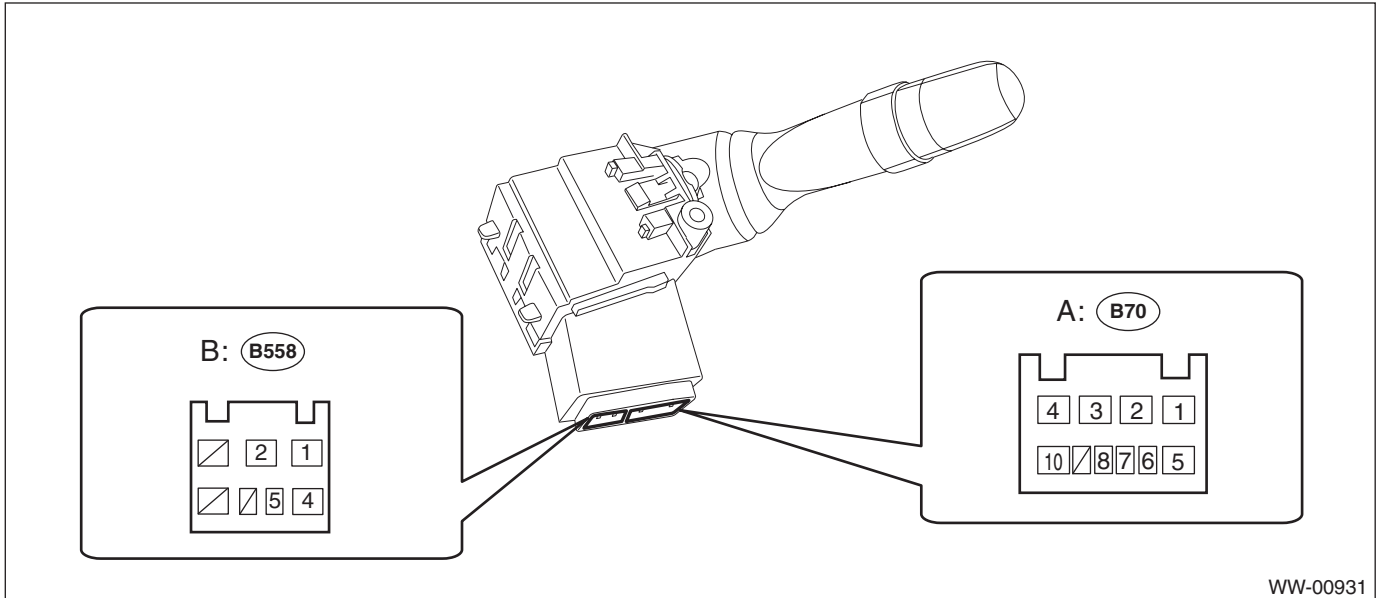

WW-00931

- (1) Set the voltmeter between terminals No. A3 (+) and No. B2 (-).
- (2) Connect the battery to connector. (Terminal No. A3 (+), terminal No. A2 & B2 (-))
- (3) Turn the front wiper switch to INT.
- (4) Connect the battery (+) to the terminal No. A3 for 5 seconds.
- (5) Connect the battery (-) to the terminal No. B2, and check the voltage between terminals No. A3 and No. A2 during intermittent operation.
- (6) Perform step (1) to (5) above when intermittent control switch is in MIN or MAX, and replace the switch if the operation is not as specified.

Intermittent stationary time

MIN: Approx. 2 seconds

MAX: Approx. 16 seconds

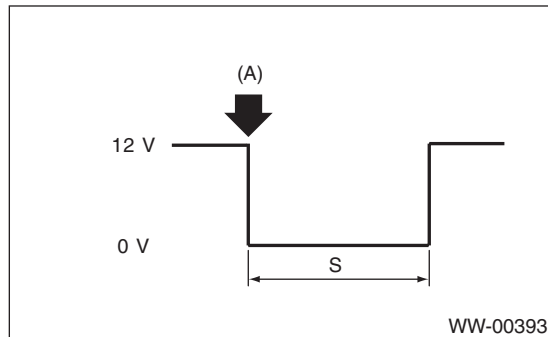

WW-00393

(A): Connect the battery (-) to the terminal No. B2.

S: Intermittent downtime (sec.)

3. REAR WIPER

1) Check input of body integrated unit

Check the input signal when the rear wiper switch is operated using Subaru Select Monitor.

- (1) Turn the ignition switch to ON.
- (2) Operate the rear wiper switch to each position of ON, INT and Washer ON.
- (3) Does the input signal change corresponding to the switch operation?
 - **Yes** → Go to step 4.
 - **No** → Go to step 2.

Combination Switch (Wiper)

2) Check harness

- (1) Turn the ignition switch to OFF, disconnect the ground cable from battery.
- (2) Disconnect the connector of body integrated unit and wiper switch.
- (3) Measure the resistance between body integrated unit and wiper switch.

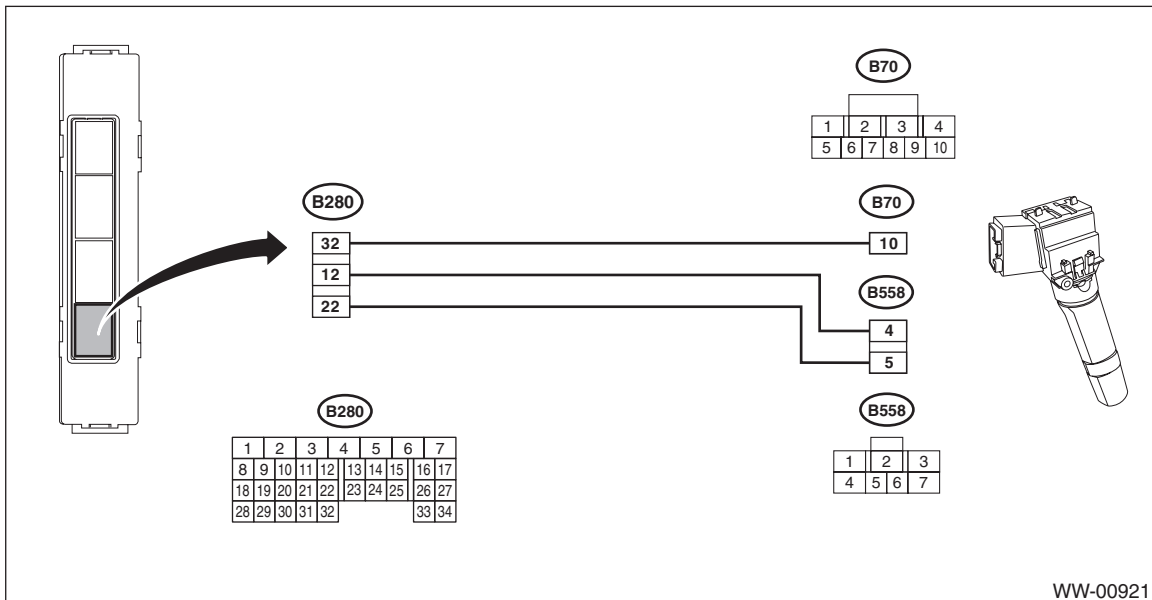

WW-00921

Connector & terminal

(B280) No. 32 — (B70) No. 10:

(B280) No. 12 — (B558) No. 4:

(B280) No. 22 — (B558) No. 5:

(4) Is the resistance less than 10 Ω?

• **Yes** → Go to step 3.

• **No** → Repair the harness between the body integrated unit and wiper switch.

3) Check input voltage of body integrated unit

(1) Connect the ground cable to battery.

(2) Turn the ignition switch to ON and check the input voltage of body integrated unit.

Connector & terminal

(B280) No. 5 (+) — Chassis ground (-):

(i171) No. 17 (+) — Chassis ground (-):

(3) Is the voltage 10 V or more?

• **Yes** → Go to step 4.

• **No** → Check the harness and fuse.

4) Check output of body integrated unit

Check the output signal when the rear wiper switch is operated using Subaru Select Monitor.

(1) Turn the ignition switch to ON.

(2) Operate the rear wiper switch to ON and Washer ON.

(3) When the operation in step (2) is performed, check the output signal of body integrated unit to rear wiper motor.

(4) When the rear wiper switch is set to ON, is ON output continuous? Also, when the washer is set to ON, is ON output?

• **Yes** → Go to step 5.

• **No** → Replace the body integrated unit. <Ref. to SL-80, Body Integrated Unit.>

Combination Switch (Wiper)

WIPER AND WASHER SYSTEMS

5) Check output of body integrated unit

Check the output signal when the rear wiper switch is operated using Subaru Select Monitor.

- (1) Turn the ignition switch to ON.
- (2) Set the rear wiper switch to INT.
- (3) When the operation in step (2) is performed, check the output signal of body integrated unit.
- (4) When the rear wiper switch is set to INT, is ON/OFF output repeated? (INT OFF time (when vehicle parked): 12 seconds)
 - **Yes** → Go to step 8.
 - **No** → Go to step 6.

6) Check harness between body integrated unit and rear wiper motor.

- (1) Turn the ignition switch to OFF, disconnect the ground cable from battery.
- (2) Disconnect the connector of body integrated unit and wiper switch.
- (3) Measure the resistance between the harness connector terminals of the body integrated unit and rear wiper motor.

Connector & terminal

(B280) No. 6 — (D43) No. 2:

- (4) Is the resistance less than 10 Ω ?
 - **Yes** → Go to step 7.
 - **No** → Repair the open circuit of the harness between body integrated unit and rear wiper motor.

7) Check stop position circuit of the rear wiper motor.

- (1) Disconnect the harness connector of the rear wiper motor.
- (2) Check the continuity of the circuit of rear wiper motor stop position.

Connector & terminal

(D43) No. 1 (+) — (D43) No. 4 (-):

- (3) Is there continuity between terminals?
 - **Yes** → Go to step 8.
 - **No** → Replace the rear wiper motor assembly.

8) Check power supply circuit of the rear wiper motor.

- (1) Disconnect the harness connector of the rear wiper motor.
- (2) Turn the ignition switch to ON.
- (3) Measure the voltage between the rear wiper motor harness connector terminal and chassis ground.

Connector & terminal

(D43) No. 3 (+) — Chassis ground (-):

- (4) Is the voltage 10 V or more?
 - **Yes** → Go to step 9.
 - **No** → Check the fuse (No. 27 in main fuse box).

9) Check ground circuit of rear wiper motor.

- (1) Turn the ignition switch to OFF.
- (2) Measure the resistance between the rear wiper motor harness connector terminal and chassis ground.

Connector & terminal

(D43) No. 4 — Chassis ground:

- (3) Is the resistance less than 10 Ω ?
 - **Yes** → Go to step 10.
 - **No** → Repair the open circuit of the rear wiper motor ground circuit.

Combination Switch (Wiper)

- 10) Check harness between body integrated unit and rear wiper motor.
- (1) Turn the ignition switch to OFF.
 - (2) Disconnect the harness connector of body integrated unit.
 - (3) Disconnect the harness connector of the rear wiper motor.
 - (4) Measure the resistance between the harness connector terminals of the body integrated unit and rear wiper motor.

Connector & terminal

(B280) No. 7 — (D43) No. 1:

- (5) Is the resistance less than 10 Ω ?
- **Yes** → Go to step 11.
 - **No** → Repair the open circuit of the harness between body integrated unit and rear wiper motor.
- 11) Check output of body integrated unit
- (1) Connect the harness connector of body integrated unit.
 - (2) Disconnect the connector of the rear wiper motor.
 - (3) Turn the ignition switch to ON.
 - (4) Measure the voltage between rear wiper motor connector and chassis ground.

Connector & terminal

(D43) No. 2 (+) — Chassis ground (-):

- (5) Is the voltage less than 1.5 V when the rear wiper switch is OFF, and is the voltage 10 V or more when the rear wiper switch is ON?
- **Yes** → Go to step 12.
 - **No** → Replace the body integrated unit. <Ref. to SL-80, Body Integrated Unit.>
- 12) Check operation of rear wiper motor.
- (1) Remove the rear wiper motor.
 - (2) Check the rear wiper motor. <Ref. to WW-44, INSPECTION, Rear Wiper Motor.>
 - (3) Does the rear wiper motor rotate normally?
- **Yes** → Finished.
 - **No** → Replace the rear wiper motor assembly.

NOTE:

Rear wiper intermittent time

Select lever position	Vehicle speed (km/h (MPH))	Intermittent stopping time (sec.)
Rev.	—	Continuous operation
Except for reverse mode	80 — (50 —)	3
	50 — 80 (31 — 50)	6
	20 — 50 (12 — 31)	9
	0 — 20 (0 — 12)	12