

7. Front Wiper Motor and Link

A: REMOVAL

- 1) Disconnect the ground cable from battery.
- 2) Remove the front wiper arm assembly.

CAUTION:

Follow the steps below when standing up the wiper arm. Not following the steps may cause contacting of wiper arms and damages of wiper arms.

1. Stand up the driver's side wiper arm.
2. Stand up the passenger's side wiper arm.

Fold the wiper arms in the reverse order.

- (1) Remove the cap.
- (2) Remove the nuts, and remove the front wiper arm assembly.

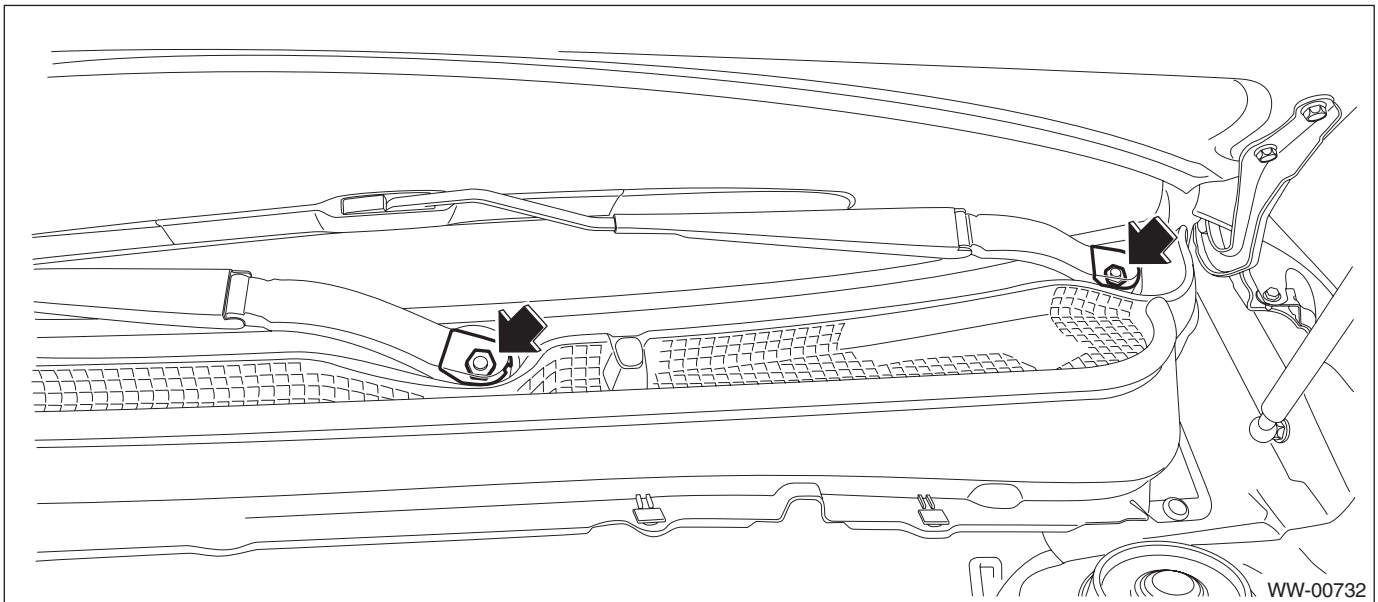

Front Wiper Motor and Link

WIPER AND WASHER SYSTEMS

3) Remove the cowl panel side.

- (1) Detach the pins of the cowl panel side.
- (2) Remove the cowl panel side from inside the fender panel by pulling it.

CAUTION:

Applying excessive pulling force may damage the cowl panel side. If it is difficult to remove, use a plastic remover or equivalent tool.

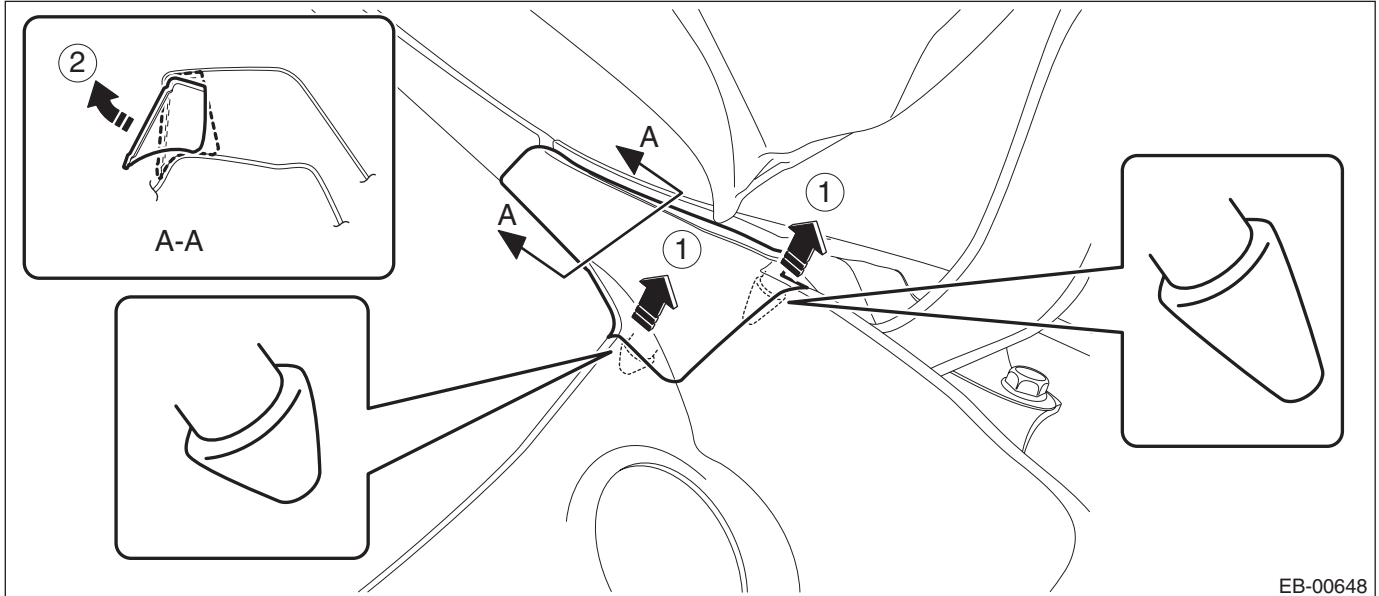

4) Remove the cowl panel.

- (1) Remove clips (A).
- (2) Push the claw of the clip (B) from both sides to remove it.

CAUTION:

- Before removing the cowl panel, use an air blower and nylon brush to sweep gravel from the lower area of the front side of the glass.
 - When removing the clip (B), push the claw of the clip from both sides.
- Be careful because the clip can be damaged if you pull unnecessarily hard on them.

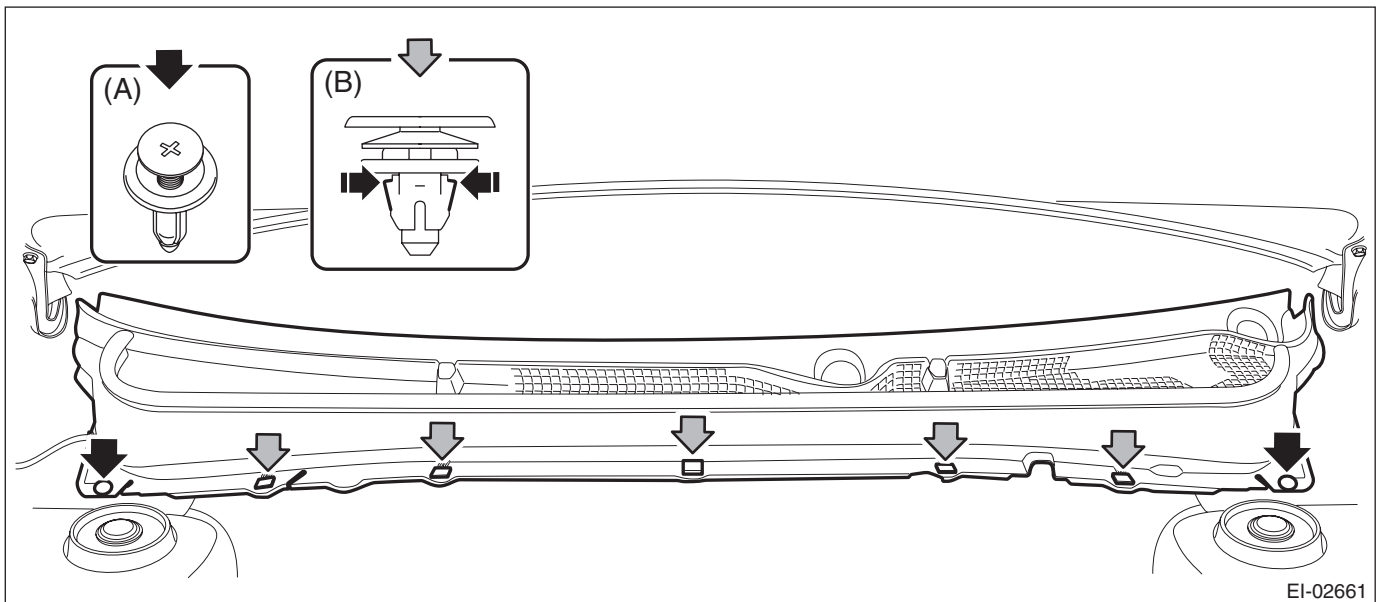

- (3) Disconnect the washer hose.

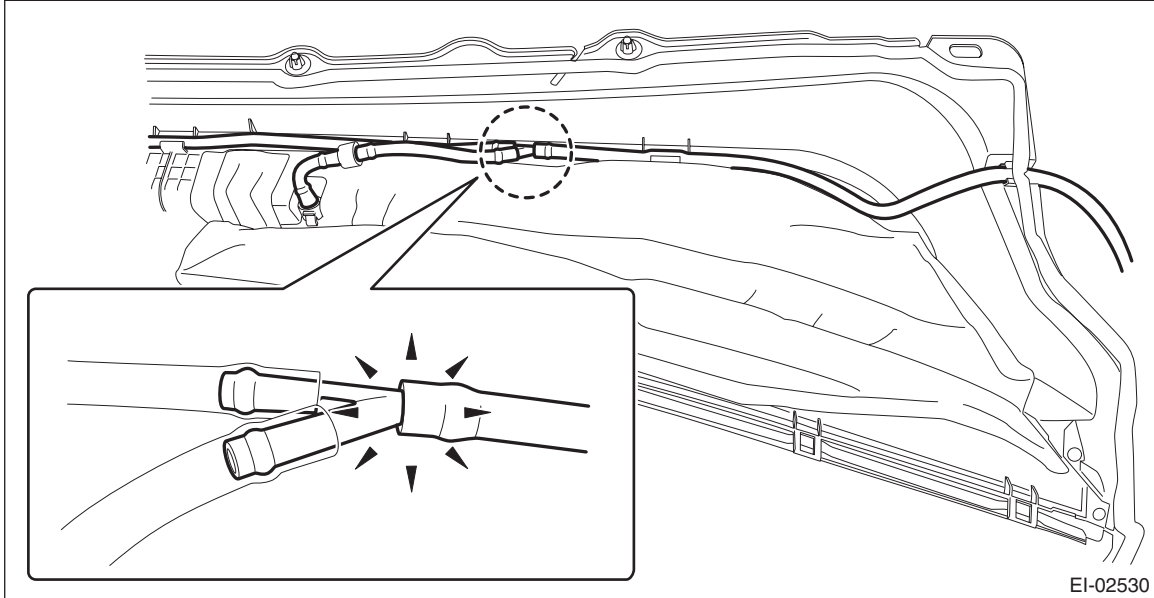

- 5) Remove the wiper link assembly.

- (1) Disconnect the connector of motor.
(2) Remove the bolts and harness clips and remove the wiper link assembly.

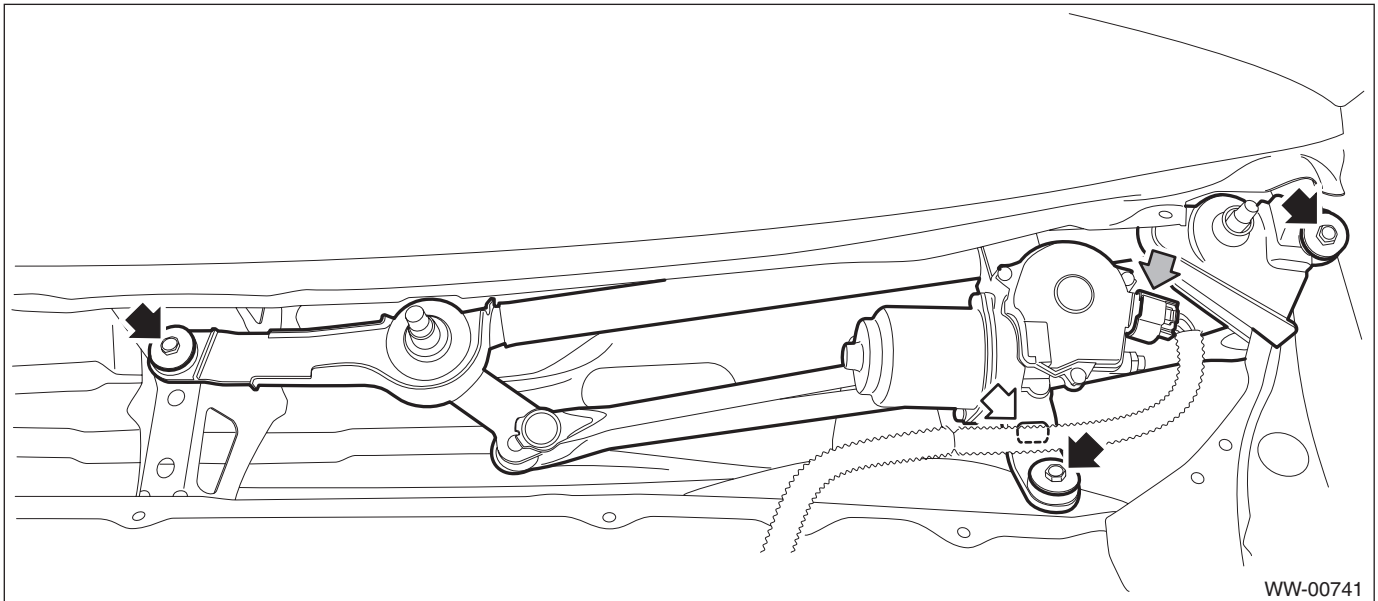

Front Wiper Motor and Link

WIPER AND WASHER SYSTEMS

6) Remove the wiper motor assembly.

(1) Remove the nuts on the link plate and motor assembly to be disconnected from the link assembly.

(2) Remove the nuts and remove the wiper motor assembly.

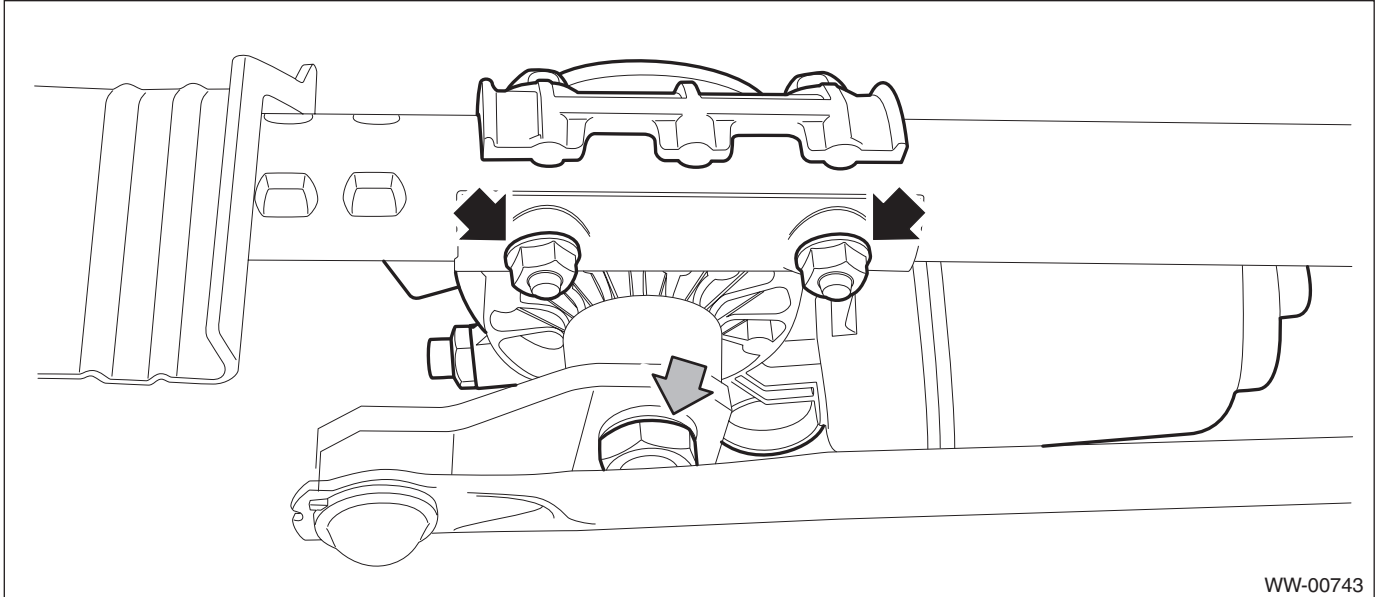

B: INSTALLATION

1) Connect the battery ground terminal.

2) To confirm that the motor is at the auto stop position, connect the harness to the motor and turn the wiper switch to ON/OFF once.

3) Disconnect the ground cable from battery.

4) Install the wiper motor assembly.

CAUTION:

Tighten the nut where rod (A) and link plate (B) is aligned in a straight line.

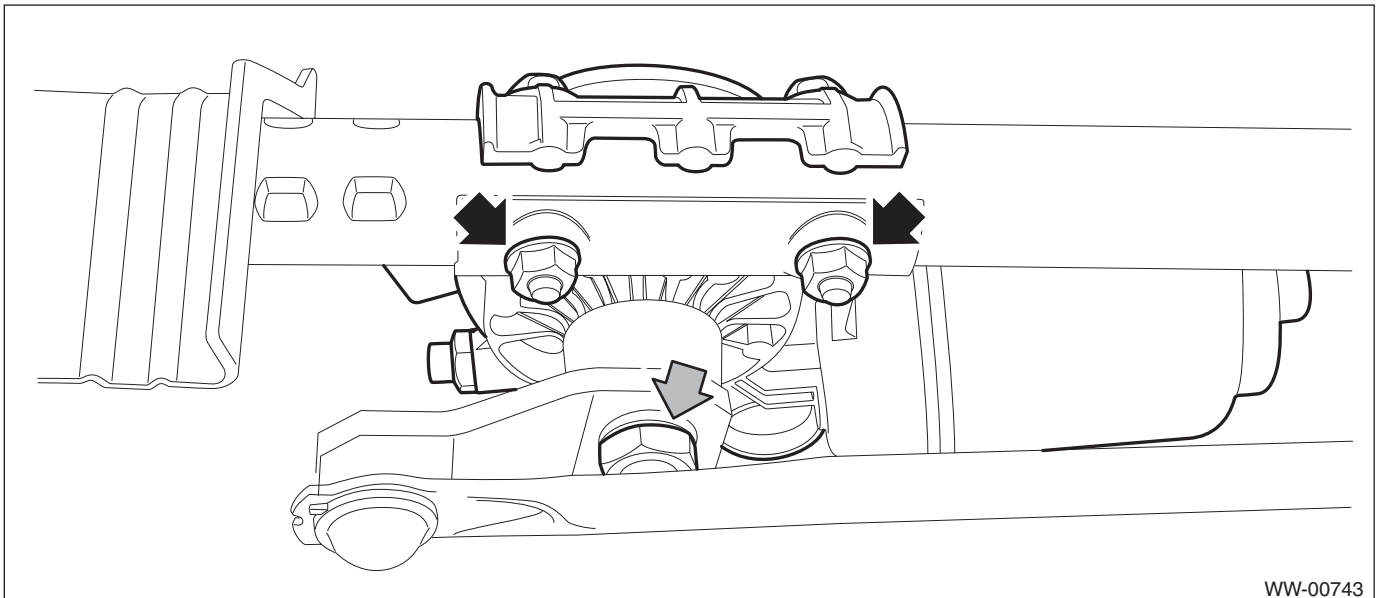

Front Wiper Motor and Link

WIPER AND WASHER SYSTEMS

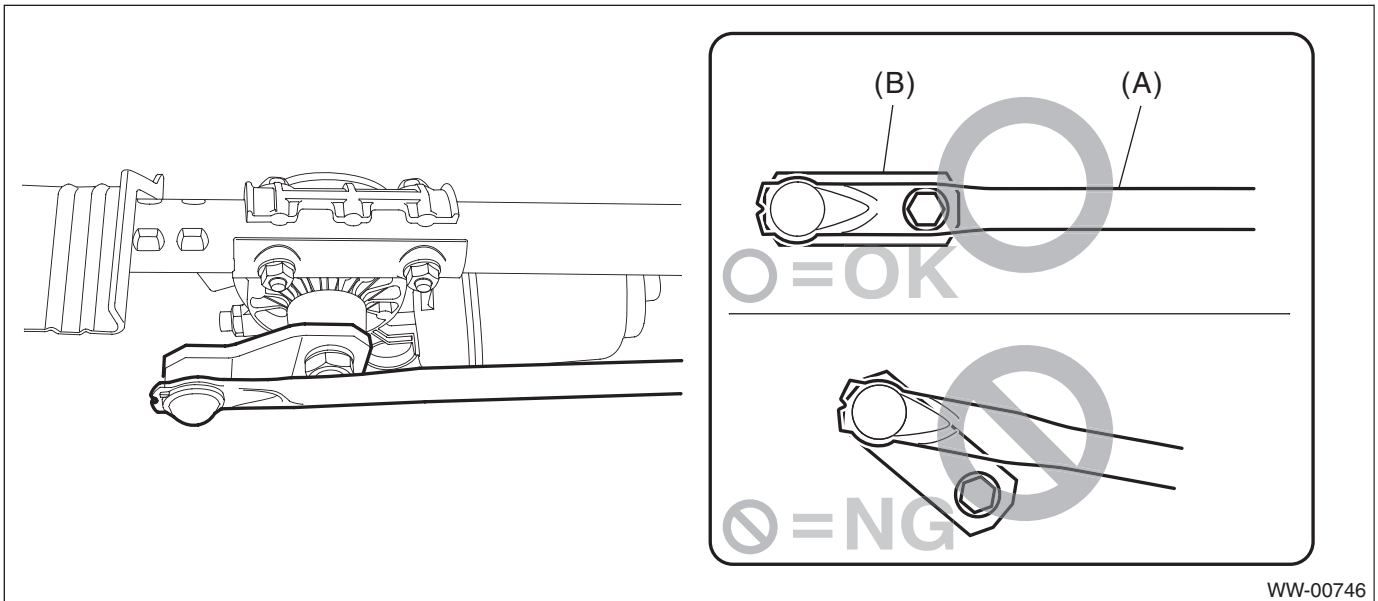

Tightening torque:

Refer to “COMPONENT” of “General Description”. <Ref. to WW-3, FRONT WIPER, COMPONENT, General Description.>

5) Install the wiper link assembly and cowl panel in the reverse order of removal.

CAUTION:

Before installing the windshield glass and cowl panel, make sure there are no gravel in the installing area.

Tightening torque:

Refer to “COMPONENT” of “General Description”. <Ref. to WW-3, FRONT WIPER, COMPONENT, General Description.>

Front Wiper Motor and Link

WIPER AND WASHER SYSTEMS

C: INSPECTION

- 1) When the battery is connected to the terminal of connectors, confirm that the motor operates at low speed.
- 2) When the battery is connected to the terminal of connectors, confirm that the motor operates at high speed.
- 3) Connect the battery to the terminals of connector, then run the motor at low speed and disconnect the terminal in mid motion.
- 4) Connect the battery and confirm that the motor stops at the automatic stop position after the motor operates at low speed again.

