

36. Push Button Start System

A: WIRING DIAGRAM

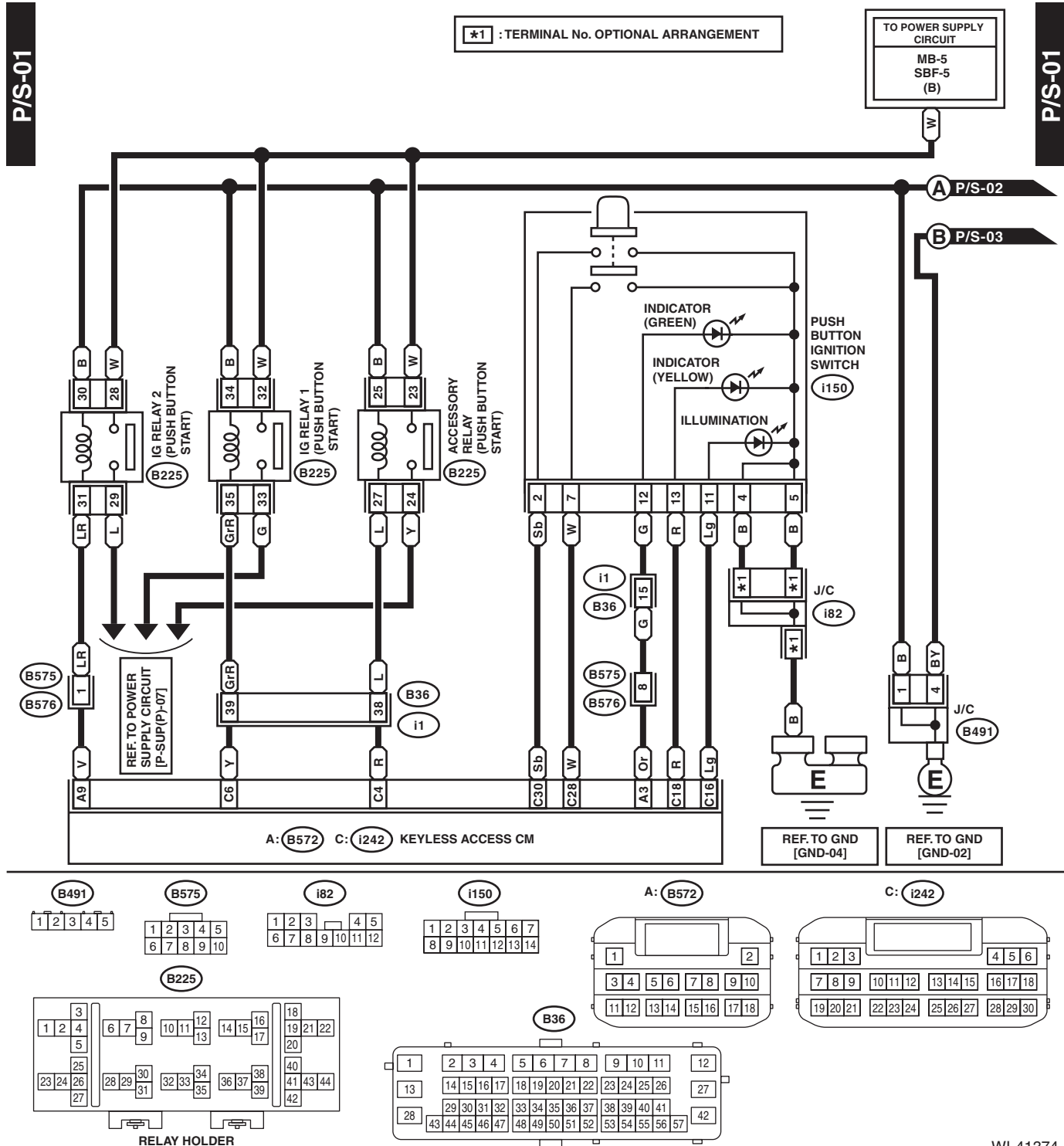

WI-41374

Push Button Start System

WIRING SYSTEM

P/S-02

P/S-02

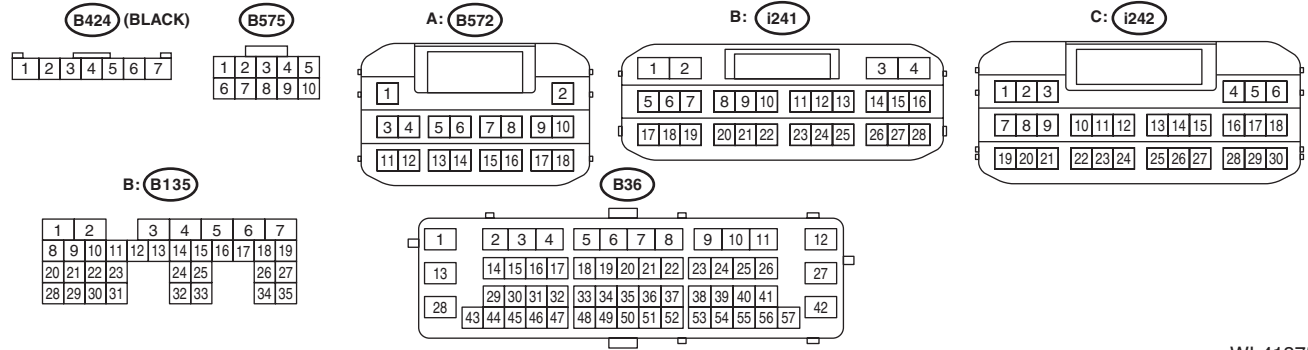
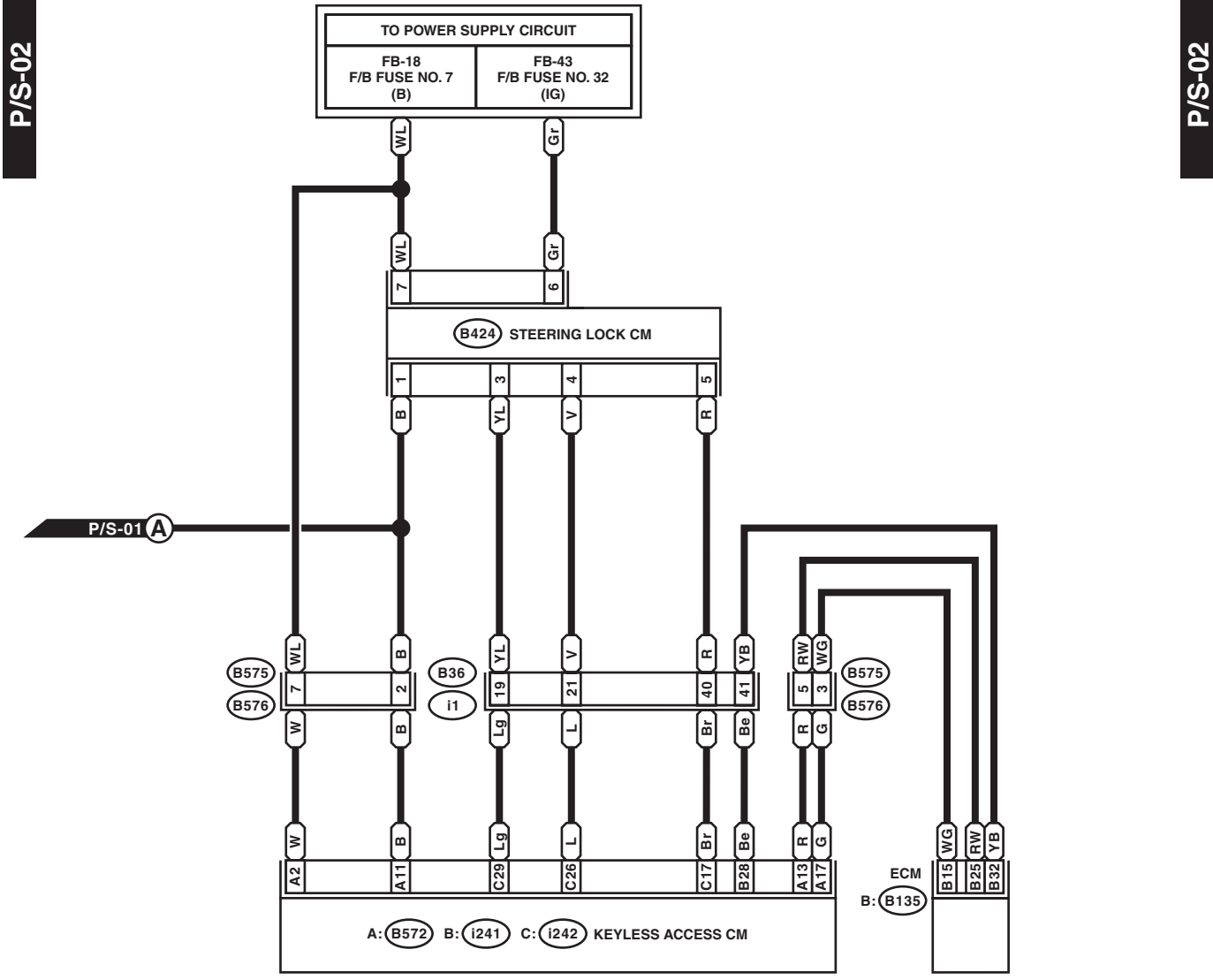

WI-41375

Push Button Start System

WIRING SYSTEM

P/S-03

P/S-03

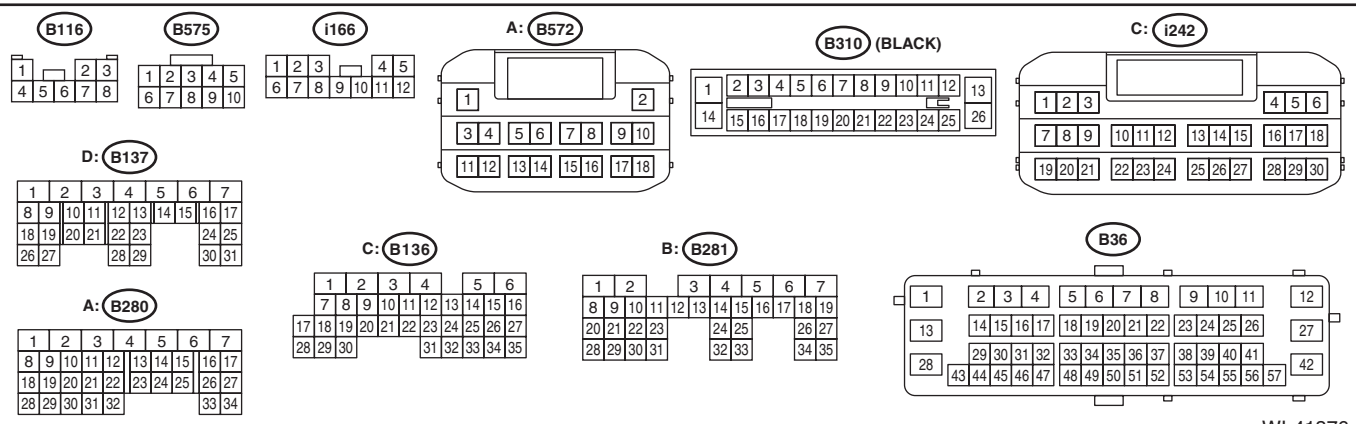
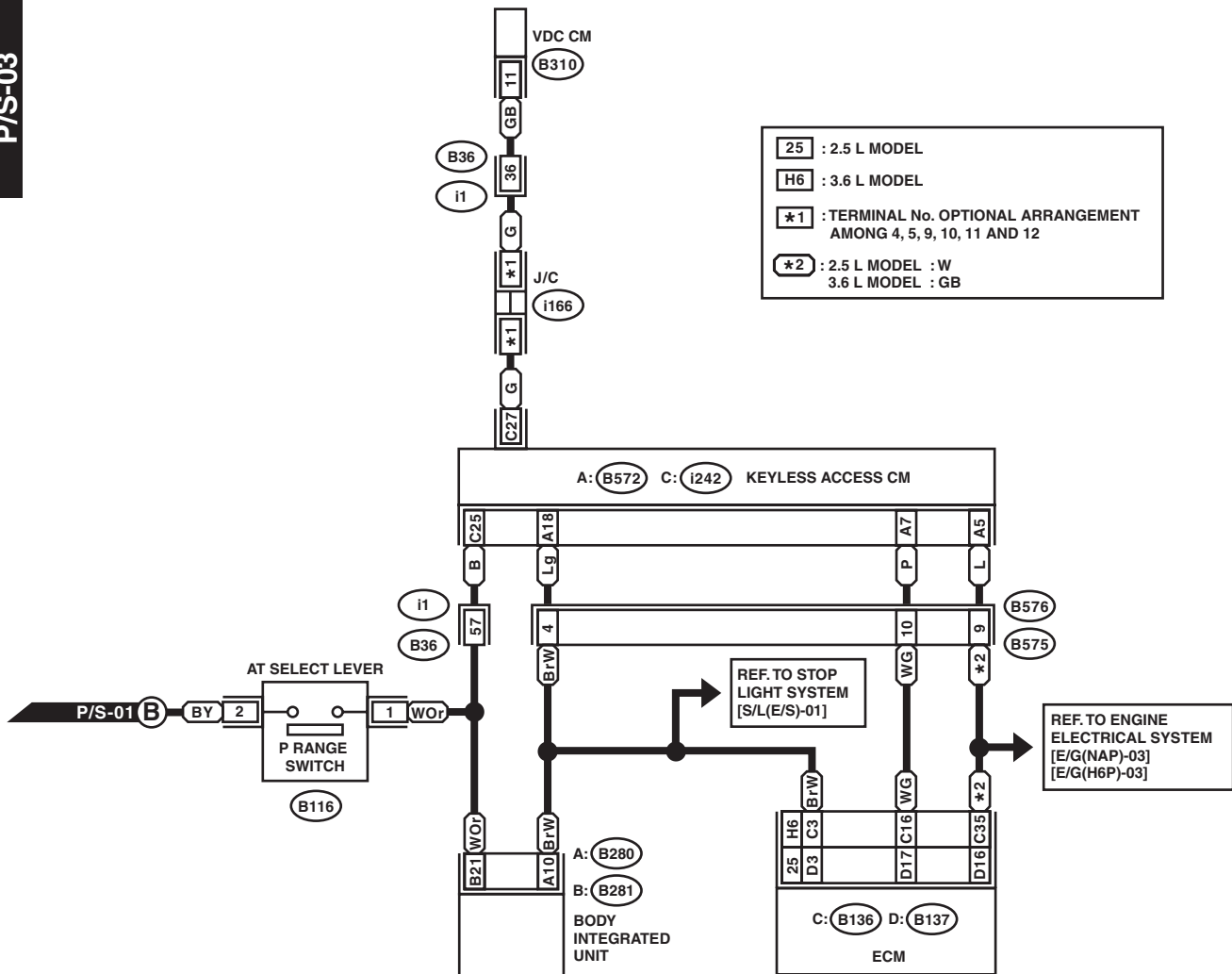

WI-41376

Push Button Start System

WIRING SYSTEM

P/S-04

P/S-04

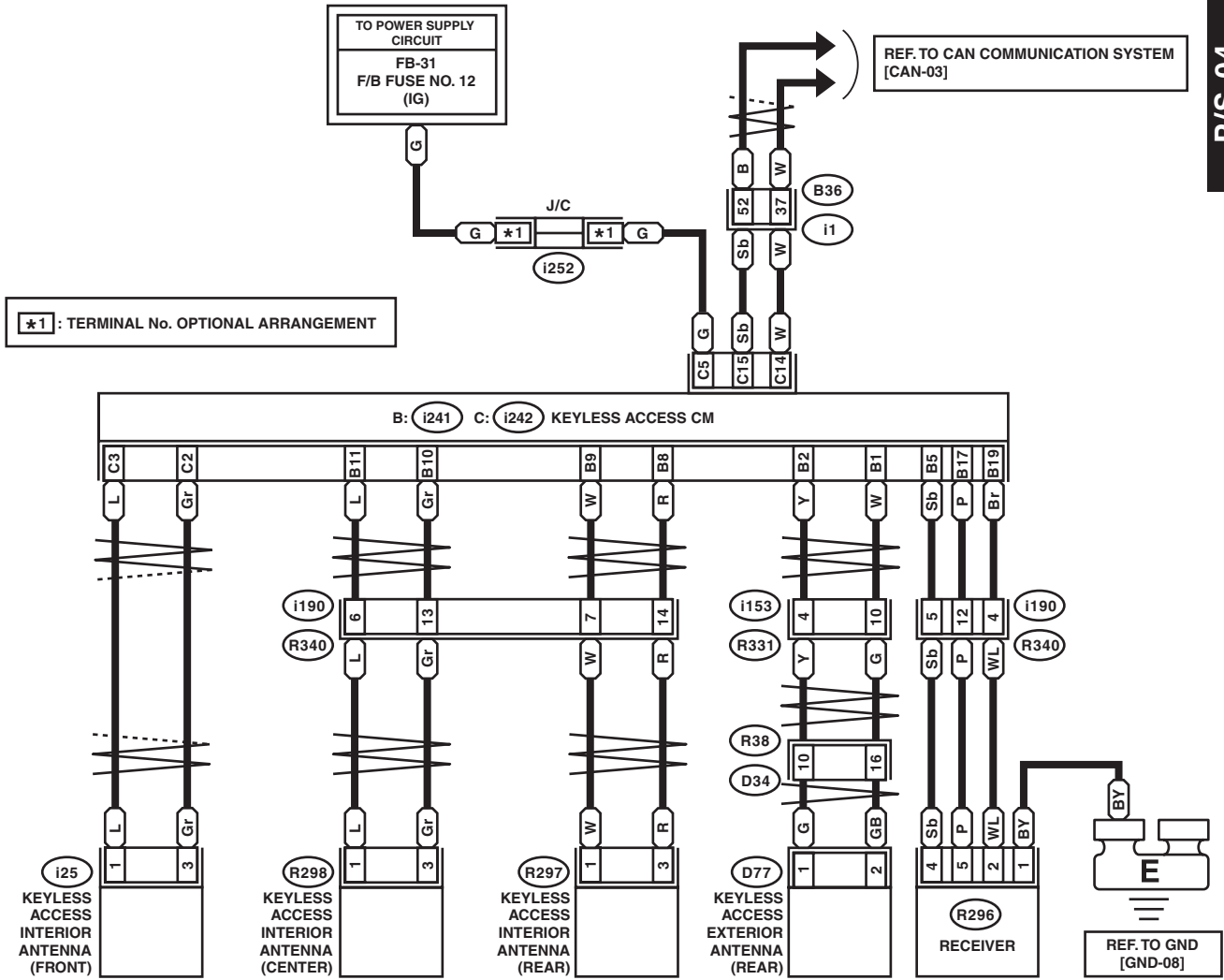

*1 : TERMINAL No. OPTIONAL ARRANGEMENT

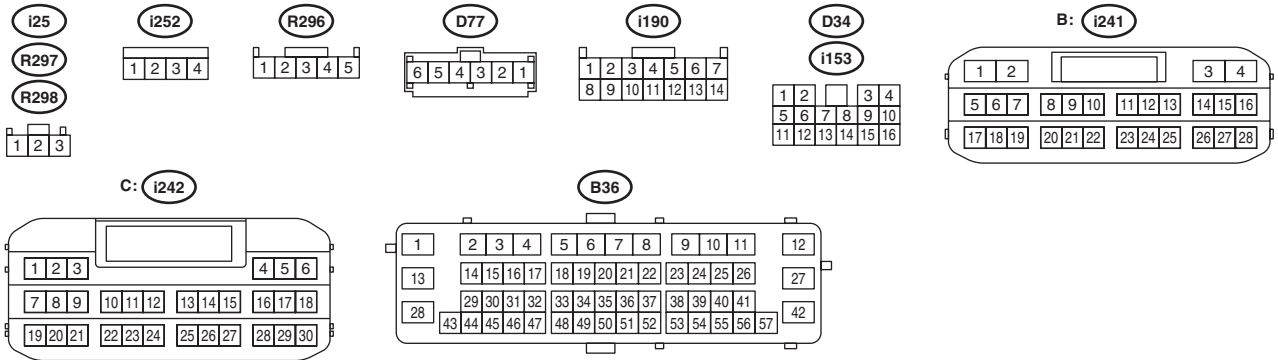

WI-41377